

PAINTS & MEDIUM





Introduction

Choong Marketing was established in 1998 by Mr K C Kang. We are an importer/exporter and distributor of stationery and art-based materials in Singapore. Since then, it is our company mission to supply our customers with quality products. Over the years we have grown at a steady pace; increasing product range, brand representation and channels to customers. As we continue to grow, we will continue to strengthen our position by working with partners with shared values and not forgetting our mission of providing ordinary products with extraordinary quality.

Manufacturing

We manufacture the DREAM brand in our own facilities and other than the regular selections, we can work with different customers on their own brand and specifications.

The Brands

If people are the company's right hand, the brands and partners would surely be its left hand. We value every brand we represent and it's our preference to work with brands that complement each other so that we would be able to grow in strength together. The following are brands that we represent exclusively:

•AMOS •CARIOCA •DREAM
•KANGARO •KCK QUALITY •KCK CRAFT
•KEBA KUM •MARVY UCHIDA •MONTANA CANS
•PLAY •SADIPAL •SIO-2 •KUSAKABE •SENNELIER
•PAPA CLAY •ALPHA COLOURS •YOUNG ARTIST

Contents

pg 4-13	Pro Acrylic Paint
pg 14-23	Studio Paint
pg 24-29	Watercolour Cakes
pg 30-35	Gesso
pg 36-41	Tempera
pg 42-43	Young Artist Acrylic
pg 44-45	Poster Colour





Flowers No.1
Impasto Technique
KCK Artist Stretched Cotton Canvas
KCK Pro Acrylic Series



Colours Used:
060 Titanium White
608 Sky Blue
203 Permanent Red
406 Yellow Mid
802 Burnt Umber
502 Sap Green



Pro Acrylic Paint Set (12 x 12ml)

AP 700





KCK's Pro Series Acrylic Paint (AP-7075)

Creamy and Rich, our pro series has a buttery-to-paste texture that retains strong, bright colours and fresh, intense shades even when mixing with other colours in the range. With 48 shades, these colours have a high pigment content with primarily single pigments. This series also includes 7 fluorescent colours and 3 metallic colours. Offering the possibility of working with layers and wash drawings that give excellent coverage to the working surfaces. It has a quick drying time of 15 minutes to an hour to create a water-resistant and gloss finish. The reduction of paint is very small depending on the shape and layers.

Quality: Fine

Based: Water

Finish: Glossy

Target: Amateur Beginners, Students, Adults, Artists

Format: 75ml

Drying Time: 15 mins-1 hour. 1-5 days depends on thickness

Dilution: Thinned by water which can result in loss of consistency

Application: Canvas, Wood Panels, Clay, Fabric, etc

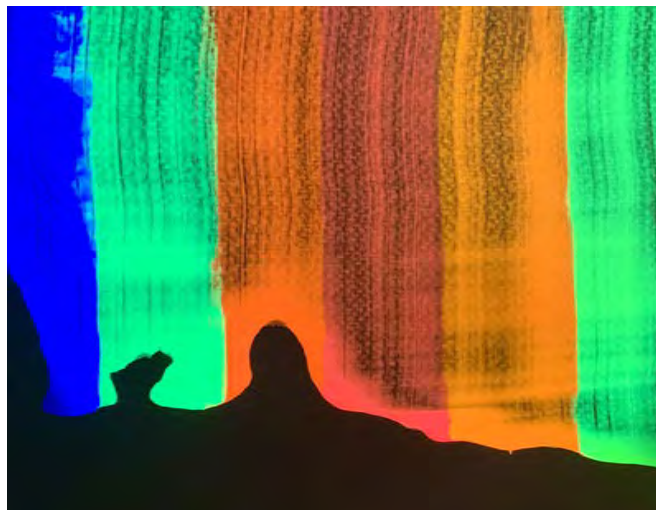

Fluo. Orange(103), Fluo. Red(102), Fluo. Green(105),
and Fluo. Blue (106)

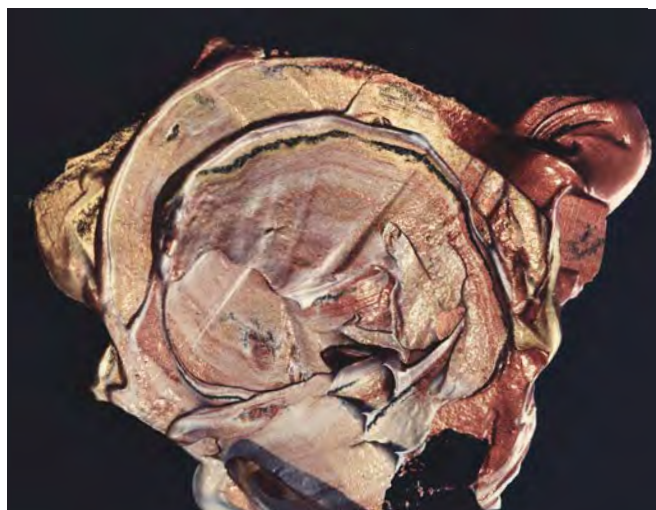

Mixture of Bronze (903), Gold (901), and Silver (902)

Pro Metallic Colours

- Consistency: Smooth-Thick
- Opacity: Semi-opaque
- Blendability with basic colours: Basic Colours remain pigmented with high shine and iridescent.

Pro Basic Colours

- Consistency: Smooth-Thick
- Opacity: Semi-opaque to Opaque
- Blendability with basic colours in the range: Primary Colours that are mixed together results in vibrant and rich secondary colours .

Pro Fluorescent Colours

- Consistency: Smooth-Flowy
- Opacity: Semi-Transparent
- Blendability with basic colours in the range: Primary Basic Colours mixes well with Primary Fluorescent Colours. Mixture remains vibrant and becomes bright secondary colours



KCK's Pro Series unveils high viscosity allowing the artist to hold peaks and retain brush strokes, making them ideal for impasto technique and palette knives strokes. Use it with KCK's Hog Hair Brushes Series that is stiff to allow the sculpting of paint and layers of texture. Although this series offers high viscosity, the signature series vary in terms of sheen and opacity. Colours like Titanium White, Black are opaque while other colours like fluorescent colours are semi-transparent depending on the qualities of the pigments being used.



Phthalocyanine Blue(601), Rouge (711), Burnt Sienna(801), with Titanium White (060)



Phthalocyanine Blue(601), Yellow Mid(406), and Permanent Red (203)

Colours are easily mixable with other colours in this series



Mixing Primary colours together results in a secondary colour, as shown above.

Mixing a primary colour - yellow, red, or blue with a secondary colour-orange, green, or purple - results in a third group known as tertiary colours.

Adding white to a colour results in a **tint** of that colour. Adding gray to a colour results in a **tone** of that colour. Adding black to a colour results in a **shade** of that colour.

TIP: Keep your mixtures simple. Don't mix too many different colours together because the colour may become "muddy." However even muddy colours can be beautiful when used properly.



Mixing Colours

Pro Series

Gloss Finish

Colours Used:



901 ★★★
Gold



513 ★★★
Emerald Green
PW6, PY3, PG7



503 ★★★
Green Light
PY3, PG7, PW6



902 ★★★
Silver



Emerald Green (AP 7075-513) + Gold (AP 7075-901) 1:3



Emerald Green (AP 7075-513) + Silver (AP 7075-902) 1:3



Green Light (AP 7075-503) + Gold (AP 7075-901) 1:3



Green Light (AP 7075-503) + Silver (AP 7075-902) 1:3



601 ★★★
Phthalocyanine Blue
PB15



901 ★★★
Gold



608 ★★★
Sky Blue
PB15, PW6, PB15:3



Phthalocyanine Blue (AP 7075-601) + Gold (AP 7075-901) 1:4



Sky Blue (AP 7075-608) + Gold (AP 7075-901) 1:3



903 ★★★
Bronze



214 ★★★
Vermillion
PO13, PR112

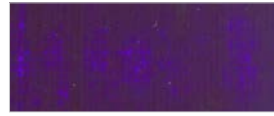

701 ★★★
Violet
PV23



902 ★★★
Silver

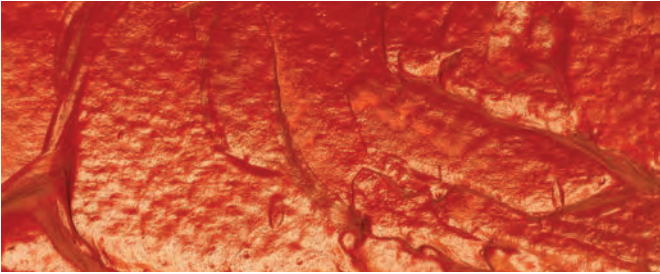

Vermillion (AP 7075-214) + Bronze (AP 7075-903) 1:3

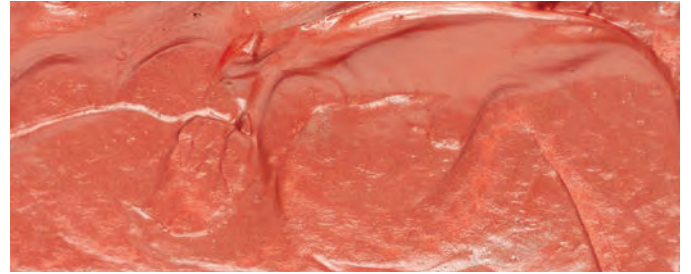

Vermillion (AP 7075-214) + Silver (AP 7075-902) 1:2

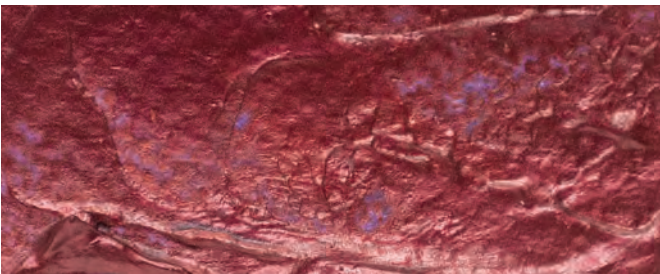

Violet (AP 7075-701) + Bronze (AP 7075-903) 1:3

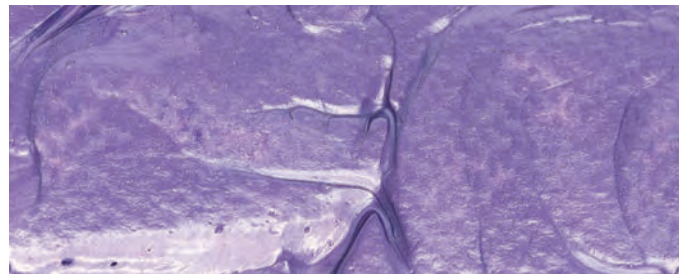

Violet (AP 7075-701) + Silver (AP 7075-902) 1:2



608 ★★★
Sky Blue
PB15, PW6, PB15:3



117 ★
Fluo. Pink



103 ★
Fluo. Orange



717 ★★★
Pink
PR146, PW6, PY1

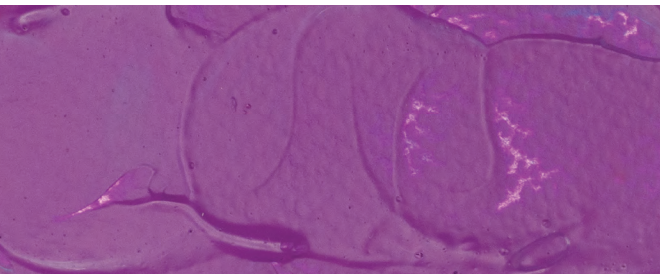

Sky Blue (AP 7075-608) + Fluo. Pink (AP 7075-117) 1:3



Pink (AP 7075-717) + Fluo. Orange (AP 7075-103) 1:3

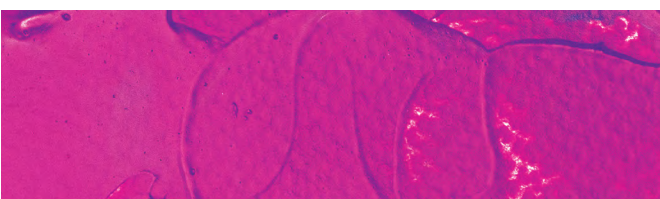

With Blue UV Light Present



With Blue UV Light Present



Pro Acrylic Paint (75ml) AP 7075

Introducing KCK Pro Series Acrylic Paint (75ml), available in a wide selection of primary through to tertiary as well as a metallic and fluorescent range of colours. The colours are bright, resistant to light, with the effect of gloss finish. Each colour can be easily mixed with any other in the range. Dries quickly into a water-resistant, durable surface. All the colours have excellent tinting strength and high colour intensity. Can be used on paper, canvas, wood, and cloth. Great medium for painting, decorative works, or collages.

Order Code	Series
AP 7075 (Colour Code)	47 COLOURS



- ✓ Water-Resistant
- ✓ High Pigment Level
- ✓ Excellent Coverage
- ✓ High Gloss Finish
- ✓ Quick Drying



407 ■ ★★★
Lemon Yellow
PY3



406 ■★★
Yellow Mid
PY1



315 ■★★★
Yellow Deep
PO13, PY1



104 □★
Fluo. Yellow



103 □★
Fluo. Orange



102 □★
Fluo. Red



215 ■★★
Orange
PO13, PR21

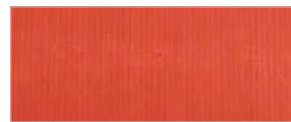

214 ■★★★
Vermillion
PO13, PR112



205 ■★★★
Scarlet
PR112, PR21



203 ■★★★
Permanent Red
PR8, PR21



201 ■★★★
Crimson
PR8, PR2, PBk11



117 □★
Fluo. Pink



719 ■★
Pink Light



717 ■★★
Pink
PR146, PW6, PY1



713 ■★★★
Fuchsia
PW6, PR112, PR146



613 ■★★
Purple Light
PV23, PW6, PR146, PBk11



711 ■★★★
Rouge
PR122, PV23



107 □★
Fluo. Purple



701 ■★★★
Violet
PV23



600 ■★★★
Prussian Blue
PB29, PB15:3, PBk7, PV23



601 □★★★
Phthalocyanine Blue
PB15

Code No.



Pigment No.

Colour Name

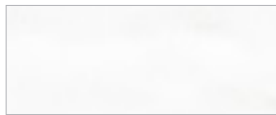

060 ■ ★★★
Titanium White
PW6

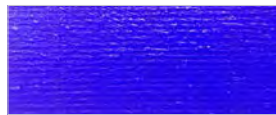

602 ▣ ★★★
Ultramarine
PB29



605 ▣ ★★★
Cobalt Blue
PW6, PB29

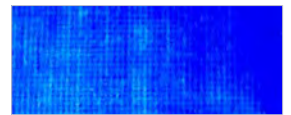

106 □ ★
Fluo. Blue



608 ▣ ★★★
Sky Blue
PB15, PW6, PB15:3



609 ▣ ★★
Pale Blue
PB15, PW6



606 ▣ ★★★
Lake Blue
PW6, PB15:3, PY3



517 ▣ ★★★
Ocean Green
PW6, PB15:3, PY3



513 ■ ★★★
Emerald Green
PW6, PY3, PG7



501 ▣ ★★★
Phthalocyanine Green
PG7



411 ▣ ★★★
Chrome Oxide Green
PG17, PBk7



502 □ ★★★
Sap Green
PG7, PY83



413 ▣ ★★★
Yellow Green
PB15, PY14, PY3



503 ▣ ★★★
Green Light
PY3, PG7, PW6

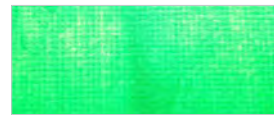

105 □ ★
Fluo. Green



402 ▣ ★★★
Olive Green
PY1, PY42, PG7



312 ▣ ★★★
Yellow Ochre
PY42



801 ■ ★★★
Burnt Sienna
PR101, PBk7



803 ▣ ★★★
Raw Umber
PR101, PY42, PBk7

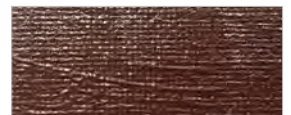

802 ■ ★★★
Burnt Umber
PR101, PBk7



010 ■ ★★★
Black
PBk7



020 ▣ ★★★
Payne's Grey
PB15, PV23, PBk7



030 ▣ ★★
Grey
PW6, PY42, PBk11



901 ▣ ★★★
Gold



903 ▣ ★★★
Bronze



902 ▣ ★★★
Silver

■ : Opaque ▣ : Semi-Opaque □ : Transparent

★★★ : Excellent Lightfastness ★★ : Good Lightfastness ★ : Average Lightfastness



- ✓ Water-Resistant
- ✓ High Pigment Level
- ✓ Excellent Coverage
- ✓ High Gloss Finish
- ✓ Quick Drying

Pro Acrylic Paint (75ml) AP 7075

Introducing KCK Pro Series Acrylic Paint (75ml), available in a wide selection of primary through to tertiary as well as a metallic and fluorescent range of colours. The colours are bright, resistant to light, with the effect of gloss finish. Each colour can be easily mixed with any other in the range. Dries quickly into a water-resistant, durable surface. All the colours have excellent tinting strength and high colour intensity. Can be used on paper, canvas, wood, and cloth. Great medium for painting, decorative works, or collages.

Order Code	Series
AP 7075 (Colour Code)	47 COLOURS

Pro	Colour	Barcode	Transparency	Lightfastness	Pigment No.
AP 7075-010	Black		Opaque <input checked="" type="checkbox"/>	Excellent ★★★	PBK7
AP 7075-020	Payne's Grey		Semi-Opaque <input checked="" type="checkbox"/>	Excellent ★★★	PB15/PV23/ PBk7
AP 7075-030	Grey		Semi-Opaque <input checked="" type="checkbox"/>	Good ★★	PW6/PY42/ PBk11
AP 7075-060	Tit. White		Opaque <input checked="" type="checkbox"/>	Excellent ★★★	PW6
AP 7075-102	Fluo. Red		Transparent <input type="checkbox"/>	Average ★	-
AP 7075-103	Fluo. Orange		Transparent <input type="checkbox"/>	Average ★	-
AP 7075-104	Fluo. Yellow		Transparent <input type="checkbox"/>	Average ★	-
AP 7075-105	Fluor. Green		Transparent <input type="checkbox"/>	Average ★	-
AP 7075-106	Fluor. Blue		Transparent <input type="checkbox"/>	Average ★	-
AP 7075-107	Fluo. Purple		Transparent <input type="checkbox"/>	Average ★	-
AP 7075-117	Fluo. Pink		Transparent <input type="checkbox"/>	Average ★	-
AP 7075-201	Crimson		Semi-Opaque <input checked="" type="checkbox"/>	Excellent ★★★	PR8/PR21/ PBk11
AP 7075-203	Perm. Red		Semi-Opaque <input checked="" type="checkbox"/>	Excellent ★★★	PR8/PR21
AP 7075-205	Scarlet		Semi-Opaque <input checked="" type="checkbox"/>	Excellent ★★★	PR112/PR21
AP 7075-214	Vermillion		Semi-Opaque <input checked="" type="checkbox"/>	Excellent ★★★	PO13/PR112
AP 7075-215	Orange		Semi-Opaque <input checked="" type="checkbox"/>	Good ★★	PO13/ PR21
AP 7075-312	Yellow Ochre		Semi-Opaque <input checked="" type="checkbox"/>	Excellent ★★★	PY42
AP 7075-315	Yellow Deep		Semi-Opaque <input checked="" type="checkbox"/>	Excellent ★★★	PO13/ PY1
AP 7075-402	Olive Green		Semi-Opaque <input checked="" type="checkbox"/>	Excellent ★★★	PY1/PY42/ PG7
AP 7075-406	Yellow Mid		Semi-Opaque <input checked="" type="checkbox"/>	Good ★★	PY1
AP 7075-407	Lemon Yellow		Semi-Opaque <input checked="" type="checkbox"/>	Excellent ★★★	PY3
AP 7075-411	Chr. Ox Green		Semi-Opaque <input checked="" type="checkbox"/>	Excellent ★★★	PG17/PBk7
AP 7075-413	Yellow Green		Semi-Opaque <input checked="" type="checkbox"/>	Excellent ★★★	PB15/PY14/ PY3



- ✓ Water-Resistant
- ✓ High Pigment Level
- ✓ Excellent Coverage
- ✓ High Gloss Finish
- ✓ Quick Drying

Pro Acrylic Paint (75ml) AP 7075

Introducing KCK Pro Series Acrylic Paint (75ml), available in a wide selection of primary through to tertiary as well as a metallic and fluorescent range of colours. The colours are bright, resistant to light, with the effect of gloss finish. Each colour can be easily mixed with any other in the range. Dries quickly into a water-resistant, durable surface. All the colours have excellent tinting strength and high colour intensity. Can be used on paper, canvas, wood, and cloth. Great medium for painting, decorative works, or collages.

Order Code	Series
AP 7075 (Colour Code)	47 COLOURS

Pro	Colour	Barcode	Transparency	Lightfastness	Pigment No.
AP 7075-501	Phthalo Green		Semi-Opaque <input checked="" type="checkbox"/>	Excellent ***	PG7
AP 7075-502	Sap Green		Transparent <input type="checkbox"/>	Excellent ***	PG7/PY83
AP 7075-503	Green Light		Semi-Opaque <input checked="" type="checkbox"/>	Excellent ***	PY3/PG7/ PW6
AP 7075-513	Emerald Green		Opaque <input type="checkbox"/>	Excellent ***	PW6/PY3/ PG7
AP 7075-517	Ocean Green		Semi-Opaque <input checked="" type="checkbox"/>	Excellent ***	PW6/PB15:3/ PY3
AP 7075-600	Prussian Blue		Semi-Opaque <input checked="" type="checkbox"/>	Excellent ***	PB29/PB15:3/ PBk7/PV23
AP 7075-601	Phthalo Blue		Transparent <input type="checkbox"/>	Excellent ***	PB15
AP 7075-602	Ultramarine		Semi-Opaque <input checked="" type="checkbox"/>	Excellent ***	PB29
AP 7075-605	Cobalt Blue		Semi-Opaque <input checked="" type="checkbox"/>	Excellent ***	PW6/PB29
AP 7075-606	Lake Blue		Semi-Opaque <input checked="" type="checkbox"/>	Excellent ***	PW6/PB15:3/ PY3
AP 7075-608	Sky Blue		Semi-Opaque <input checked="" type="checkbox"/>	Excellent ***	PB15/PW6/ PB15:3
AP 7075-609	Pale Blue		Semi-Opaque <input checked="" type="checkbox"/>	Good **	PB15/PW6
AP 7075-613	Purple Light		Semi-Opaque <input checked="" type="checkbox"/>	Good **	PV23/PW6/ PR146/PBk11
AP 7075-701	Violet		Semi-Opaque <input checked="" type="checkbox"/>	Excellent ***	PV23
AP 7075-711	Rouge		Semi-Opaque <input checked="" type="checkbox"/>	Excellent ***	PR122/PV23
AP 7075-713	Fuschia		Opaque <input type="checkbox"/>	Excellent ***	PW6/PR122/ PR146
AP 7075-717	Pink		Semi-Opaque <input checked="" type="checkbox"/>	Good **	PR146/PW6/ PY1
AP 7075-719	Pink Light		Semi-Opaque <input checked="" type="checkbox"/>	Average *	-
AP 7075-801	Burnt Sienna		Opaque <input type="checkbox"/>	Excellent ***	PR101/PBk7
AP 7075-802	Burnt Umber		Opaque <input type="checkbox"/>	Excellent ***	PR101/PBk7
AP 7075-803	Raw Umber		Semi-Opaque <input checked="" type="checkbox"/>	Excellent ***	PR101/PY42/ PBk7
AP 7075-901	Gold		Semi-Opaque <input checked="" type="checkbox"/>	Excellent ***	-
AP 7075-902	Silver		Semi-Opaque <input checked="" type="checkbox"/>	Excellent ***	-
AP 7075-903	Bronze		Semi-Opaque <input checked="" type="checkbox"/>	Excellent ***	-



KCK
CREA-ART
- the finer side of art -
: make an impression :
Acrylic
COLOUR

acrylfarbe · peinture acrylique · vernice acrilica

portrait pink (flesh)

durability ★★ transparency ■

Studio
collection
matt

CE

When used according to the instructions, this product does not contain any substances that are classified as carcinogenic, mutagenic or toxic for reproduction (CMR) in the 15th, 17th and 18th categories. The product is therefore suitable for use in children's toys and other articles intended for children. The product is also suitable for use in articles intended for use in the food chain. The product is also suitable for use in articles intended for use in the food chain. The product is also suitable for use in articles intended for use in the food chain.

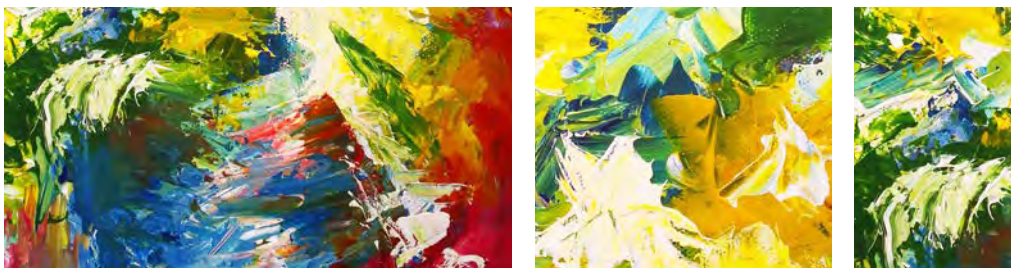

Sunrise No.1

Impasto Technique
KCK Artist Stretched Cotton Canvas
KCK Studio Acrylic Series

Colours Used:
060 Titanium White
514 Turquoise
202 Carmine Red
405 Azo Yellow
802 Burnt Umber
020 Payne's Grey



KCK's Studio Series Acrylic Paint (AP-5500)

Rich in colours, our studio acrylic series is made specifically for acrylic painters of all levels such as muralists, street artists, students. With 36 colours, these are high quality and affordable acrylic paint packaged in a 520ml bottle. These bottles include a stuck-free bottle cap designed with a cross nozzle to avoid difficulty in opening the bottle and increase the flow of paint. With a creamy heavy consistency, these studio paint bottles have excellent coverage for impasto and palette knife paintings. It can be applied to a multitude of surfaces such as canvas, paper, board, unglazed ceramic, air dry clay, and wooden painting panels. Dries quickly into a matte and water-resistant surface. The reduction of paint varies with the layers of pigments.



A cross nozzle that helps to keep your bottles clean and stuck-free



Studio Series - Matte Finish

Studio Basic Colours

- **Consistency:** Smooth-Thick
- **Opacity:** Semi-opaque to Opaque
- **Blendability with other basic colours:** Mixture can become a little muddy but "muddy" colours can be beautiful when used correctly
- **Blendability with Titanium White:** Mixture becomes vibrant

Studio Metallic Colours

- **Consistency:** Smooth-Thick
- **Opacity:** Semi-opaque to Opaque
- **Blending Silver with Basic Colours:** Reflective pigments of Silver is prominent in the mixture. A small amount of basic colours are needed to mix with Silver
- **Blending Copper with Basic Colours:** Iridescent of the copper colour that gives a slight refraction



Titanium White(060), Silver(902), Gold(901) & Copper(903)



KCK's Studio Series showcases high viscosity allowing the artist to hold peaks and retain brush strokes. Primary Colours like Ultramarine, Carmine Red, and White & Black contain single pigment while secondary, tertiary colours are made up of 3-4 pigments. Due to the affordable rate of this paint, the 520ml make up the rich and creamy colours by adding lot more pigments. Therefore when mixing multiple colours would result in a muddy colour. However, muddy colours can be beautiful when used correctly.



Phthalocyanine Green(807), Light Violet(702), Burnt Umber (802) with Titanium White (060)



Yellow Mid(406), Sky Blue(608), Carmine Red (202)



Quality: Fine

Based: Water-Based

Finish: Matte Finish

Target: Amateur Beginners, Students, Adults, Artists

Format: 520 ml

Drying Time: 30 mins-3 hours, 1-5 days depending on thickness.

Dilution: Thinned by water which can result in loss of consistency.

Application: Canvas, Wood Panels, Clay, Unglazed Ceramic, Fabric, etc.



Mixing Colours

Studio series

Matte Finish

Colours Used:



902 ■ ★★
Silver



717 ■ ★★
Pink
PR146/PY1/PW6



307 ■ ★★
Brilliant Orange
PR21/PR4



903 ■ ★★★★★
Copper



Brilliant Orange (AP 5500-307) + Silver (AP 5500-902) 1:3



Brilliant Orange (AP 5500-307) + Copper (AP 5500-903) 1:3



Pink (AP 5500-717) + Silver (AP 5500-902) 1:3



Pink (AP 5500-717) + Copper (AP 5500-903) 1:2



406 ■ ★★
Yellow Mid
PY1/PY3



060 ■ ★★★★★
Titanium White
PW6



601 ■ ★★★★★
Phthalocyanine Blue
PB15:3/PBk11

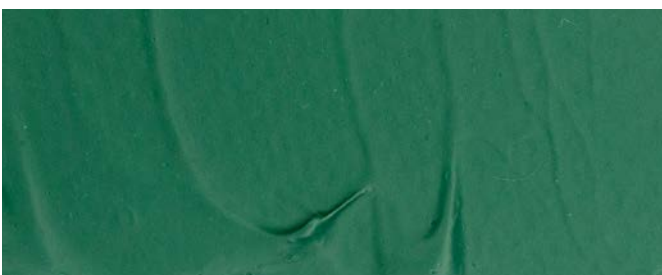

Yellow Mid + Phthalocyanine Blue 1:1



Yellow Mid + Phthalocyanine Blue + Titanium White 1:1:1



902 ■ ★★
Silver



502 ■ ★★
Sap Green
PG7/PY3/PY42



702 ■ ★★
Light Violet
PV3/PR122/PW6



903 ■ ★★★★★
Copper

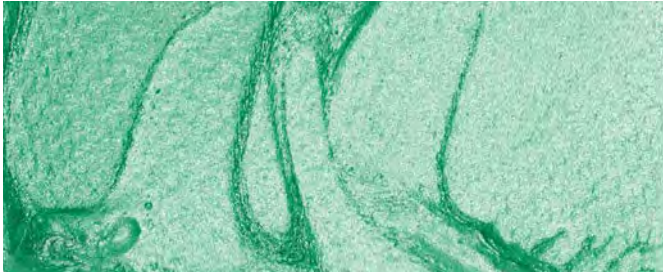

Sap Green (AP 5500-502) + Silver (AP 5500-902) 1:3

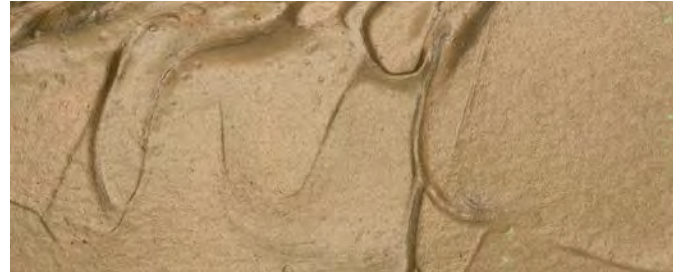

Sap Green (AP 5500-502) + Copper (AP 5500-903) 1:2

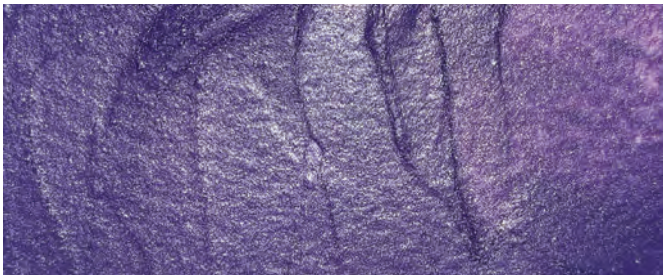

Light Violet (AP 5500-702) + Silver (AP 5500-902) 1:2



Light Violet (AP 5500-702) + Copper (AP 5500-903) 1:2



When mixing metallic colour such as Silver with other Basic colours in the Studio range, Silver (AP 5500-902) has blue undertones and neutralizes warm colours like Brilliant Orange (AP 5500-307). Mixing any basic colours with silver in the range, mixture becomes glitter-like with prominent silver glitter. Mixture has a matte finish that is rough to the touch.

When mixing metallic colours such as Copper with other basic colours in the Studio range, the mixture becomes slightly iridescent. Copper has a neutral cool and warm undertone. The final outcome of the mixture will depend on the tones and volume of the basic colours.

When mixing primary basic colours in the range, some colours might look less vibrant but with the addition of titanium white, the mixture will look more vibrant and opaque.

Overall, Studio Paint Series has noticeable reduction of paint with 20% shrinkage.



Studio Series Acrylic Paint (520ml) AP 5500

Available in bottles of 520ml, KCK Studio Series Acrylic Paint is perfect for both studio and mural work. 36 vivid colours to choose from, these acrylic paints are lightfast with excellent surface coverage. Dries quickly into a water-resistant, durable surface. Suitable for application on many different types of surfaces, it is also quick-drying with a matte finish. Each colour can be easily mixed with any other in the range. All the colours have excellent tinting strength and high colour intensity. Can be used on paper, canvas, wood, and cloth. Great medium for painting, decorative works, or collages.

Order Code	Series
AP 5500 (Colour Code)	36 COLOURS



- ✓ Water-Resistant
- ✓ High Pigment Level
- ✓ Excellent Coverage
- ✓ Matte Finish
- ✓ Quick Drying



409 ■ ★★
Naples Yellow
PY42/PW6



407 ■ ★★
Lemon Yellow
PY1

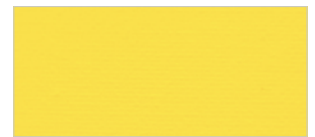

406 ■ ★★
Yellow Mid
PY1/PY3



405 ■ ★★
Azo Yellow
PW6/PY1/PO13



314 ▣ ★★★
Cadmium Hue Deep
PY1/PO13



307 ■ ★★
Brilliant Orange
PR21/PR4



215 ▣ ★★
Orange
PR21/PO13



205 ■ ★★
Scarlet
PR112



202 ▣ ★★★
Carmine Red
PR170



201 ■ ★★★
Crimson Red
PR170/PV23



317 ▣ ★★★
Portrait Pink
PW6/PY42/PO5



717 ■ ★★
Pink
PR146/PY1/PW6



715 ■ ★★
Pink Hot
PR146/PR122/PW6

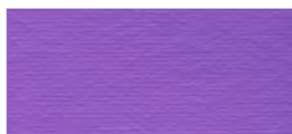

702 ■ ★★
Light Violet
PV3/PR122/PW6



701 ■ ★★★
Violet
PV23

Code No.



Pigment No.

Colour Name

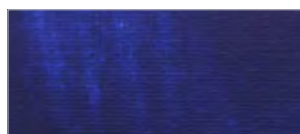

601 ■ ★★★
Phthalocyanine Blue
PB15:3/PBk11



602 ■ ★★★
Ultramarine
PB29



605 ■★★
Cobalt Blue
PB29/PW6



605 ■★★★
Sky Blue
PW6/PB15:1

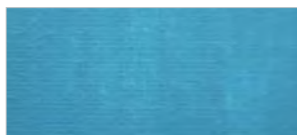

807 ■★★
Primary Cyan
PB15/PG7/PW6

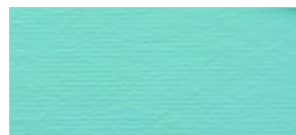

514 *Turquoise*



807 □★★★★
Phthalocyanine Green
PG7/PB15



502 ■★★
Sap Green
PG7/PY3/PY42



503 ■★★
Green Mid
PY3/PG7/PY42



413 ■★★
Leaf Green
PG7/PY3/PY1/PW6



312 ■★★★★
Yellow Ochre
PY42



804 ▣★★★★
Raw Sienna
PY42/PR101/PBk11

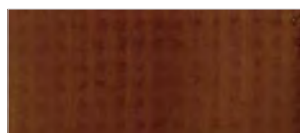

801 ■★★★
Burnt Sienna
PR101

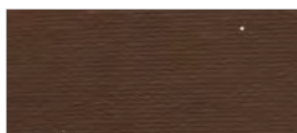

802 ■★★★
Burnt Umber
PBk7/PY42/PR101



010 ■★★★
Black
PBk7



807 ■★★★★
Payne's Grey
PB1/PW6/PBk7/PG7



030 ■★★
Grey
PBk7/PB29/PW6/PY42



060 ■★★★★
Titanium White
PW6



902 ■★★
Silver



901 ■★★
Gold



903 ■★★★★
Copper

■ : Opaque ▣ : Semi-Opaque □ : Transparent

★★★★ : Excellent Lightfastness ★★★ : Good Lightfastness ★★ : Average Lightfastness



- ✓ Water-Resistant
- ✓ High Pigment Level
- ✓ Excellent Coverage
- ✓ Matte Finish
- ✓ Quick Drying

Studio Series Acrylic Paint (520ml) AP 5500

Available in bottles of 520ml, KCK Studio Series Acrylic Paint is perfect for both studio and mural work. 36 vivid colours to choose from, these acrylic paints are lightfast with excellent surface coverage. Dries quickly into a water-resistant, durable surface. Suitable for application on many different types of surfaces, it is also quick-drying with a matte finish. Each colour can be easily mixed with any other in the range. All the colours have excellent tinting strength and high colour intensity. Can be used on paper, canvas, wood, and cloth. Great medium for painting, decorative works, or collages.

Order	Series
AP 5500 (Colour Code)	36 COLOURS

Studio	Colour	Barcode	Transparency	Lightfastness	Pigment No.
AP 5500-010	Black		Opaque ■	Good ★★★	PBk7
AP 5500-020	Payne's Grey		Opaque ■	Excellent ★★★★★	PB1/PW6/ PBk7/PG7
AP 5500-030	Grey		Opaque ■	Average ★★	PBk7/PB29/ PW6/PY42
AP 5500-060	Titanium White		Opaque ■	Good ★★★	PW6
AP 5500-201	Crimson Red		Opaque ■	Good ★★★	PR170/PV23
AP 5500-202	Carmine Red		Semi-Opaque ▣	Good ★★★	PR170
AP 5500-205	Scarlet		Opaque ■	Average ★★	PY1/PY3
AP 5500-215	Orange		Opaque ■	Average ★★	PR21/PO13
AP 5500-307	Brilliant Orange		Opaque ■	Average ★★	PR21/PR4
AP 5500-312	Yellow Ochre		Opaque ■	Good ★★★	PY42
AP 5500-314	Cadmium Hue Deep		Semi-Opaque ▣	Good ★★★	PY1/PO13
AP 5500-317	Portrait Pink		Semi-Opaque ▣	Average ★★	PW6/PY42/ PO5
AP 5500-405	Azo Yellow		Opaque ■	Average ★★	PW6/PY1/PO13
AP 5500-406	Yellow Mid		Opaque ■	Average ★★	PY1/PY3
AP 5500-407	Lemon Yellow		Opaque ■	Average ★★	PY1
AP 5500-409	Naples Yellow		Opaque ■	Average ★★	PY42/PW6
AP 5500-413	Leaf Green		Opaque ■	Average ★★	PG7/PY3/PY1/ PW6
AP 5500-501	Phthalo Green		Opaque ■	Excellent ★★★★★	PG7/PB15



- ✓ Water-Resistant
- ✓ High Pigment Level
- ✓ Excellent Coverage
- ✓ Matte Finish
- ✓ Quick Drying

Studio Series Acrylic Paint (520ml) AP 5500

Available in bottles of 520ml, KCK Studio Series Acrylic Paint is perfect for both studio and mural work. 36 vivid colours to choose from, these acrylic paints are lightfast with excellent surface coverage. Dries quickly into a water-resistant, durable surface. Suitable for application on many different types of surfaces, it is also quick-drying with a matte finish. Each colour can be easily mixed with any other in the range. All the colours have excellent tinting strength and high colour intensity. Can be used on paper, canvas, wood, and cloth. Great medium for painting, decorative works, or collages.

Order	Series
AP 5500 (Colour Code)	36 COLOURS

Studio	Colour	Barcode	Transparency	Lightfastness	Pigment No.
AP 5500-502	Sap Green		Opaque ■	Average ★★	PG7/PY3/PY42
AP 5500-503	Green Mid		Opaque ■	Average ★★	PY3/PG7/PY42
AP 5500-514	Turquoise		-	-	-
AP 5500-601	Phthalo Blue		Opaque ■	Good ★★★	PB15:3/PBk11
AP 5500-602	Ultramarine		Opaque ■	Good ★★★	PB29
AP 5500-605	Cobalt Blue		Opaque ■	Average ★★	PB29/PW6
AP 5500-608	Sky Blue		Opaque ■	Good ★★★	PW6/PB15:1
AP 5500-701	Violet		Opaque ■	Good ★★★	PV23
AP 5500-702	Light Violet		Opaque ■	Average ★★	PV3/PR122/ PW6
AP 5500-715	Pink Hot		Opaque ■	Average ★★	PR146/PR122/ PW6
AP 5500-717	Pink		Opaque ■	Average ★★	PR146/PY1/ PW6
AP 5500-801	Burnt Sienna		Opaque ■	Good ★★★	PR101
AP 5500-802	Burnt Umber		Opaque ■	Good ★★★	PBk7/PY42/ PR101
AP 5500-804	Raw Sienna		Semi-Opaque ▣	Excellent ★★★★★	PY42/PR101/ PBk11
AP 5500-807	Primary Cyan		Opaque ■	Average ★★	PB15/PG7/PW6
AP 5500-901	Gold		Opaque ■	Average ★★	-
AP 5500-902	Silver		Opaque ■	Average ★★	-
AP 5500-903	Copper		Opaque ■	Excellent ★★★★★	-

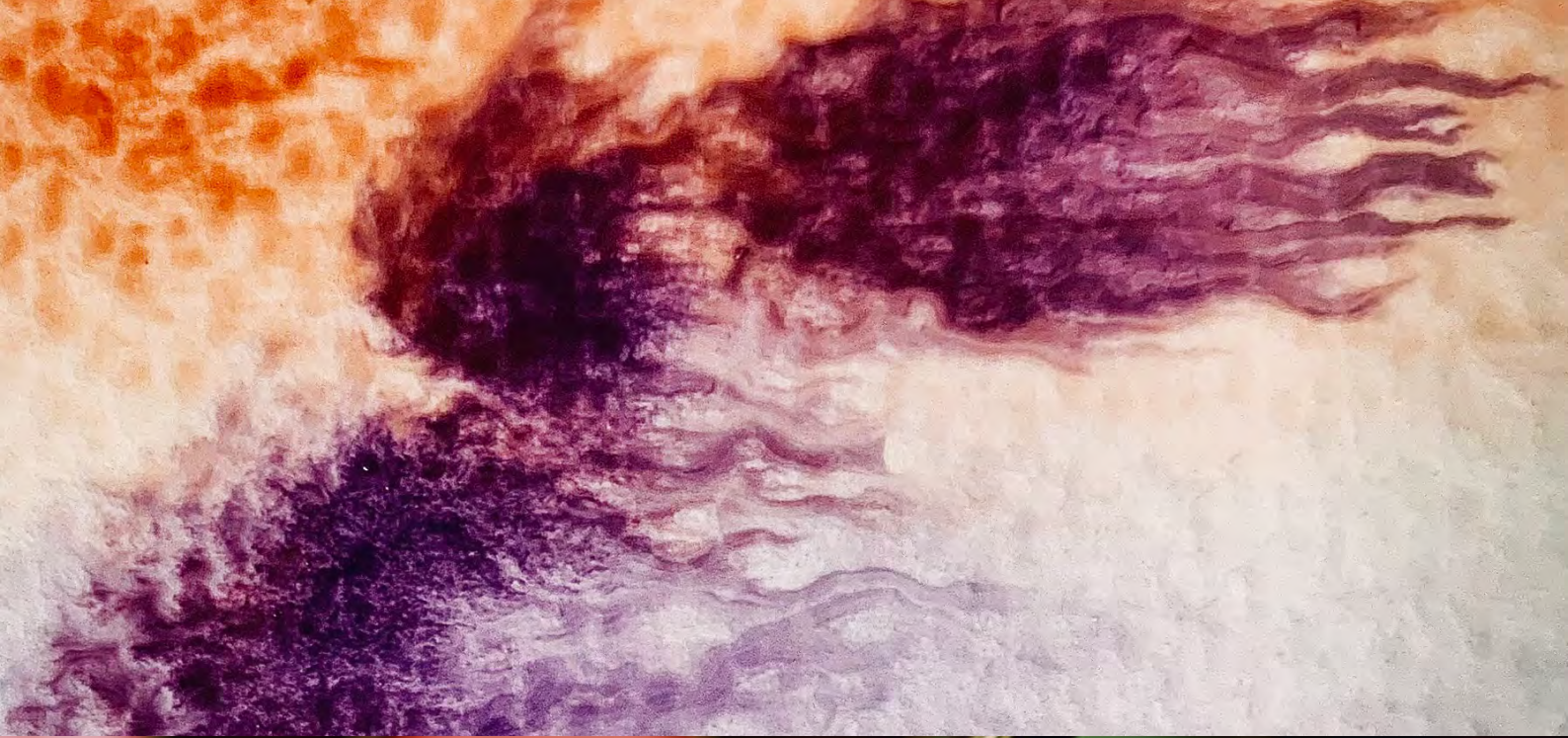

Materials being used:
KCK Watercolour Cake Set of 36 Colours
(SKU WC C36)
Dream Artist Watercolor Paper Series I
(WCP300A4-15)





Set of 12 Colours
Code: WC C12



8 888313 115008



Set of 16 Colours
Code: WC C16



8 888313 115015



Set of 28 Colours
Code: WC C28



8 888313 115022



Set of 36 Colours
Code: WC C36



8 888313 115039



(Premium)
Set of 12 Colours
+ 3 Whites

Code: WC C1233



8 888313 107782

KCK Watercolour Cake

KCK Watercolour Cakes - Available in a wide range of colours according to the artist's needs and creative vision. All the colours have excellent vibrance and high colour intensity. The cover of the Watercolour Cakes are palettes designed for easy mixing. An ideal solution for a painting session outside. All the Watercolour Sets come with a brush each suitable for beginners and students who would like to dwell in Watercolour Painting. Can be used on Water Colour Paper, Sketchbook, or Watercolour Canvases.

Order	Series
WC C12	12 Colours
WC C16	16 Colours
WC C28	28 Colours
WC C36	36 Colours
WC C1233	12 Colours + 3 Whites

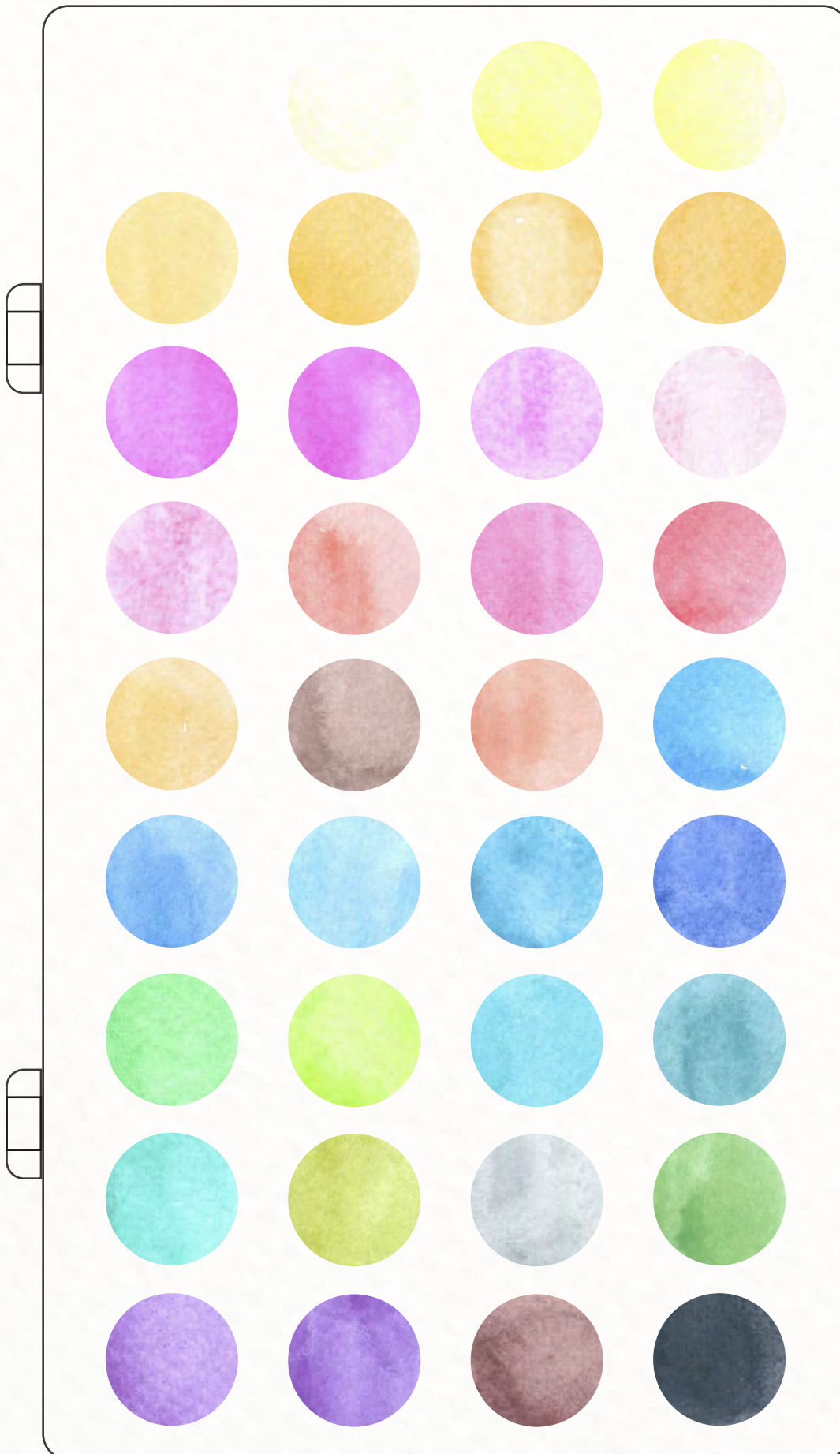

Watercolour Cake (Set of 36 Colours)
SKU WC C36

Swatches are done on:
Dream Artist Watercolor Paper Series I
(WCP300A4-15)





KCK Watercolour Cakes Series (WC C)

Quality: Fine

Based: Water Activated

Grade: Student Grade

Finish: Most pans dries chalky, some pans dries satin-like and creamier than others.

Target: Confirmed amateur, Adult, Student, Amateur beginner

Dilution: Water, according to the desired intensity.

Application Supports: Watercolour Paper, Drawing Paper, Pastel Paper, Colour Pencil Paper, Primed Canvas, and cards.

Directions:

1. Spray the pans down.
2. Wait a few minutes.
3. Swirl a firm wet brush over the cake to "activate" the paints.

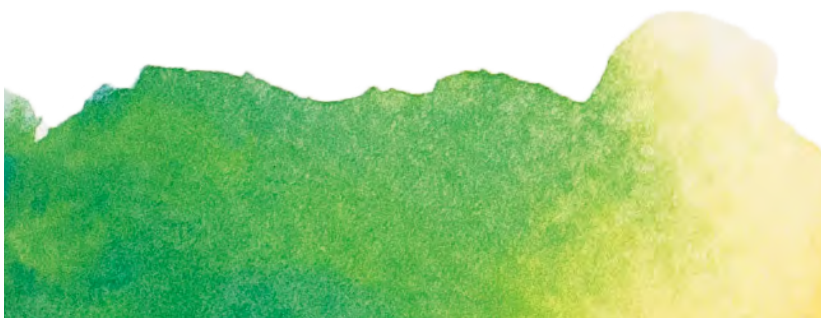
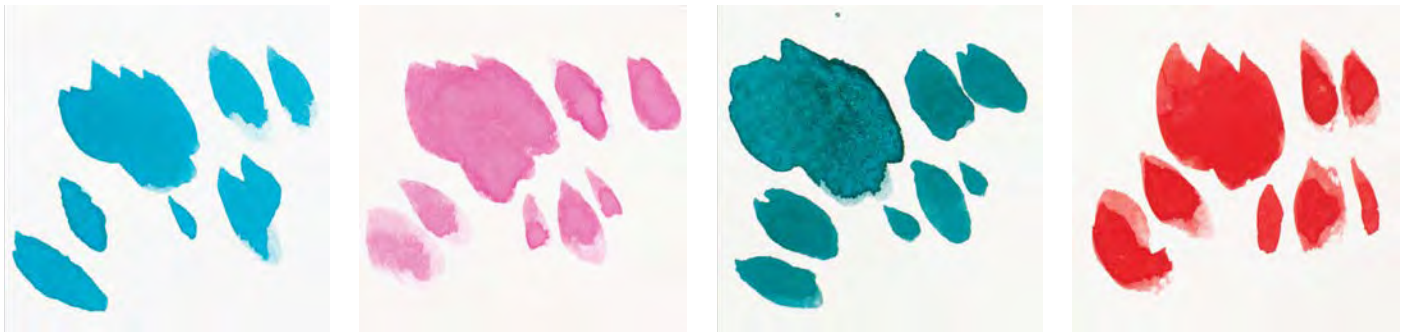

These colours are dense, brightly saturated. These colours dry down and remain to hold out the vibrant colours. With a decent array of colours, the texture is light and thin, with high transparency.

These watercolour pans come in a lightweight and sturdy plastic box that makes them easy for storage and carrying. The removable cover design of the case allows it to not only work as a normal cover for the palette, but also as a palette that keeps the watercolour paints organized and tidy.

Perfect for outdoor sketching, card making natural journaling, splattering art and watercolour practicing.

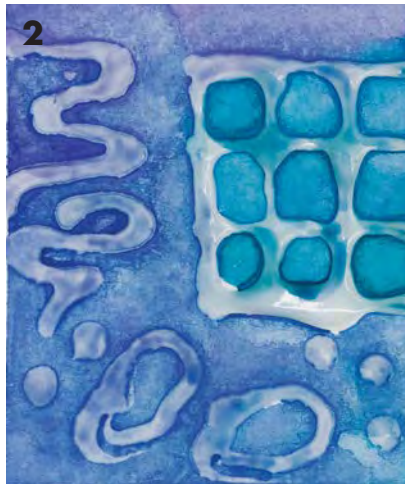

Layering Watercolours

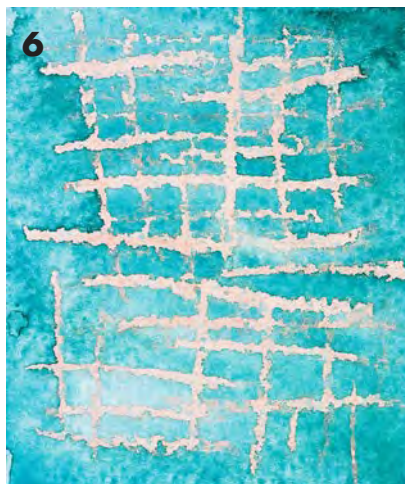
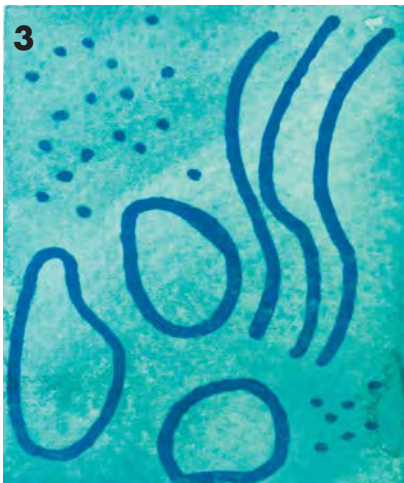

1. KCK Artist Grade Gesso

2. KCK PVA White Glue

3. Marvy Uchida Industrial Paint Marker

4. Sea Salt

5. Highlighter

6. KCK Young Artist Classic Crayon

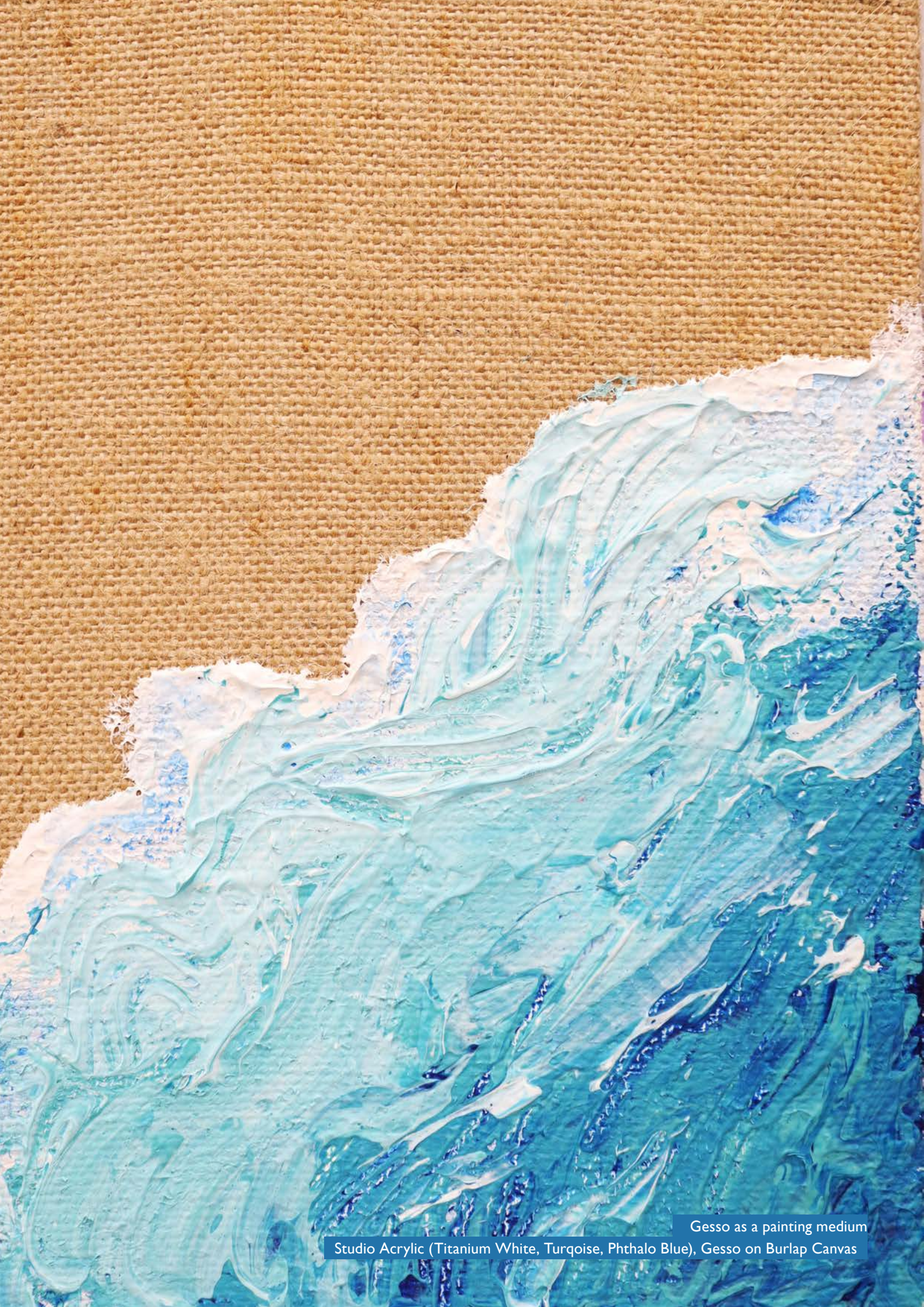

Gesso as a painting medium
Studio Acrylic (Titanium White, Turquoise, Phthalo Blue), Gesso on Burlap Canvas

KCK Gesso Artist Grade

250/500/1200ml.

Code: AP 401

KCK Artist Grade Gesso is a primer and base undercoat before starting with your Acrylic or Oil Painting. Offering a polished, even, and smooth preparatory coat for better adherence of the paint on the artist's canvas surfaces. Its thickness and density provide excellent coverage of the rough texture on canvases. The Gesso contains a high pigment level and opaqueness, bringing out the vibrance and the brightness of the paint. Giving an easier placement of paint as it flows over our Gesso Primer. The Gesso's thick density provides a strong bond between the canvas and the layer of paint providing a long-lasting and durable layer before painting.



1200 ml



500 ml



250 ml



Order	Series
AP 401-0250	250ml
AP 401-0500	500ml
AP 401-1200	1200ml

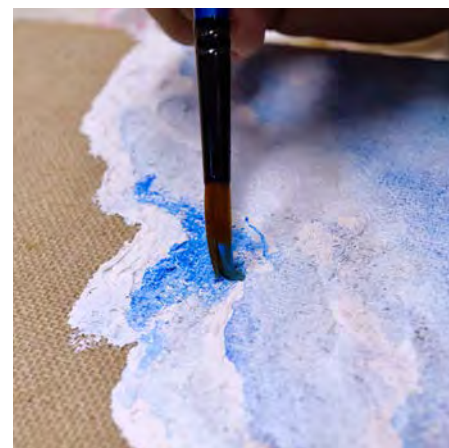

(Watercolour on Gesso) Mixed Media Painting

- ✓ Artist Grade Primer
- ✓ High Pigment Level
- ✓ Excellent Coverage
- ✓ High Opacity
- ✓ Suitable for Acrylic & Oil Painting
- ✓ Strong Grip for Paints on Canvas
- ✓ Offers a smooth painting surface



Thick Gesso, Thin Gesso mixed with Water, Gesso mixed with Acrylic Paint



Canvas with 3 layers of Gesso



No Gesso



Use gesso as a modelling paste to create a texture



Lighten your paint with gesso as a replacement for white paint



KCK Artist Grade Gesso

Quality: Fine

Grade: Artist Grade, Thick & Opaque

Target: Beginners, Students, Adults, Artists

Format: 250ml, 500ml, 1200ml

Finish: Semi-Matte Finish

Drying Time: 1-2 hours. 1-7 days depending on thickness

Application: Canvas, Wood Panels, Drawing Paper, Watercolour Paper, Cardboards, etc.

Application Tool: Stiff Hog Hair Brushes, Palette Knife and Tools with teeth to create texture.

Description: Preparing Surfaces for painting. Improves the adhesion of acrylic or oil paint layers. Applied on a clean or non greasy surface. Great for mixed media; Watercolour, Alcohol Markers, Collages, Scrapbooking, Printmaking.

Mixed Media

Watercolour on Journal Paper with (Gesso)

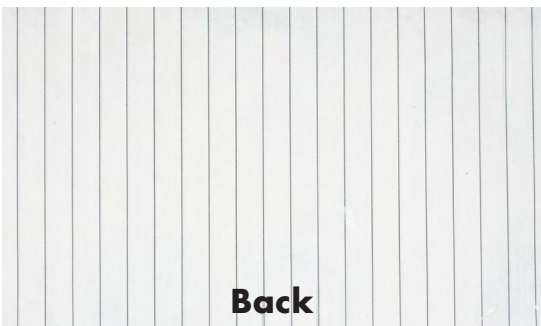

Back

Watercolour on Journal Paper

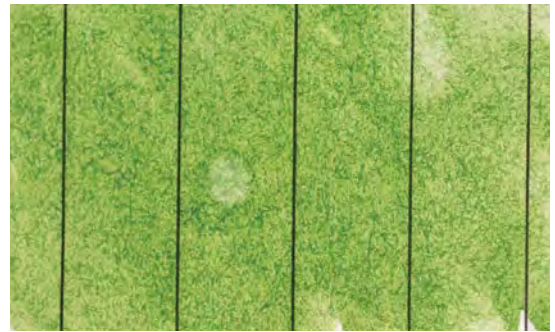
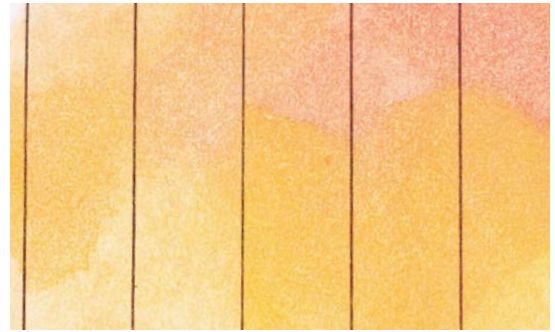
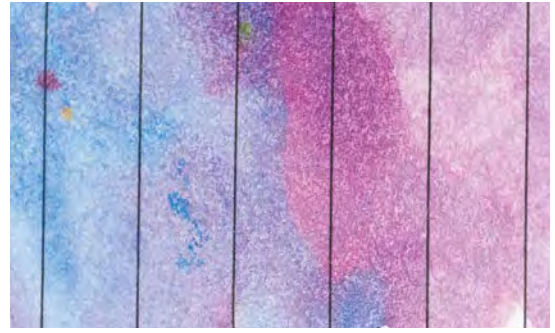

Back



1 MODELLING PASTE

Great for creating Texture.

Create cracks, wavy, stone texture to a surface by using a palette knife or tools with teeth.

2 LIGHTEN COLOURS

Lighten your acrylic

paints without the use of white paint while also creating a thick paste.

3 IMPROVES ADHESION

Prepare surfaces to be smoothly painted on with acrylic/oil layers.

4 PROTECTS PAPER

Protects thin paper from tearing and bleeding.

Providing a strong base for Journal, drawing paper to be used with any wet mediums.

5 COVERS OLD WORK SURFACES

It takes only 3 layers of Gesso to completely erase an old work and convert it into a brand new working surface.



how it works

Scan to see

5 REASONS TO CHOOSE KCK ARTIST GRADE GESSO





Young Artist Tempera Paint (500ml) AP 9500

Code	Weight	Qty/Inner	Qty/ Carton	Measurement	Volume
AP 9500	11.4kg	3/12	48/1	30x21x20cm	0.013m ³



Tempera Paint Basic (500ml)



060 White 400 Yellow 300 Orange 200 Red 717 Pink 611 Purple
 608 Sky Blue 600 Blue 506 Leaf Green 502 Sap Green 800 Brown 010 Black

Tempera Paint Neon (500ml)



x 3 bottles



104 Neon Yellow 102 Neon Red 117 Neon Pink 103 Neon Orange 106 Neon Blue 105 Neon Green

Tempera Paint Glitter (500ml)



x 12 bottles



134 Glitter Yellow 132 Glitter Red 137 Glitter Pink 136 Glitter Blue 135 Glitter Green 199 Glitter Glow-In-Dark

Tempera Paint Pearl & Metallic (500ml)



126 Pearl Blue 107 Pearl Purple 125 Pearl Green 901 Gold 902 Silver 903 Copper

Young Artist Tempera Paint

Code: AP 9500

KCK Young Artist Tempera Paint is a water-soluble paint that is available in a wide selection of basic, neon, glitter, pearl, and metallic range of colours. The high intensity of the colour provides excellent coverage and allows the artists to achieve fine details. Its washable, water-based formula is also suitable for children aged 3 and above because it contains no dangerous or harmful chemicals. It flows smoothly onto paper, cardboard, cloth, wood, or canvases suitable for arts and crafts projects.

Order Code	Series
AP 9500	30 COLOURS



- ✓ Washable Formula
- ✓ Vibrant Colours
- ✓ Non-Toxic and Acid-Free
- ✓ Suitable for age 3 and above
- ✓ Conforms to EN71-3

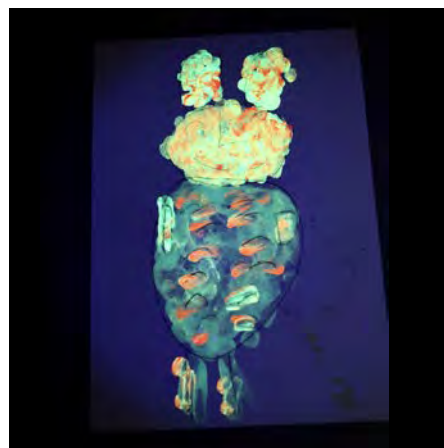

Neon & Glitter Series glows in the dark



Great for Finger Painting!



Easy to wash off





YOUNG
ARTIST
WASHABLE
TEMPERA
PAINT
NEON
CE

Young Artist Tempera Paint Swatches

Order Code	Series
AP 9500	30 COLOURS

Tempera Paint Basic (500ml)

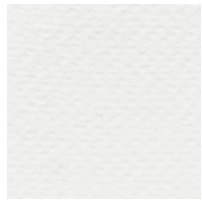

060 White



400 Yellow



300 Orange



200 Red



717 Pink

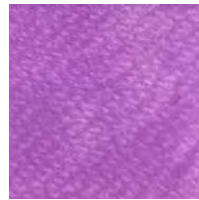

611 Purple

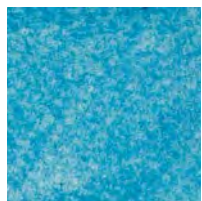

608 Sky Blue

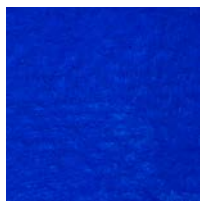

600 Blue



506 Leaf Green

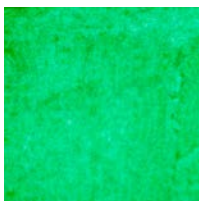

502 Sap Green

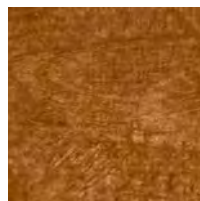

800 Brown



010 Black

Tempera Paint Neon (500ml)



104 Neon Yellow

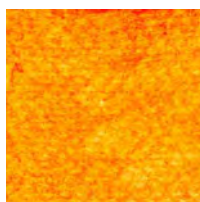

103 Neon Orange



102 Neon Red

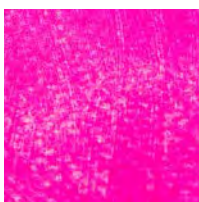

117 Neon Pink

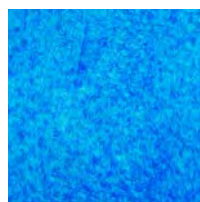

106 Neon Blue



105 Neon Green

Tempera Paint Glitter (500ml)



134 Glitter Yellow



132 Glitter Red

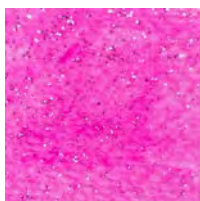

137 Glitter Pink

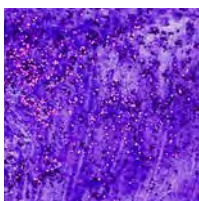

136 Glitter Blue



135 Glitter Green



199 Glitter Glow-In-Dark

Tempera Paint Pearl & Metallic (500ml)



126 Pearl Blue



125 Pearl Green

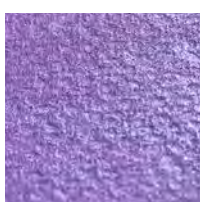

107 Pearl Purple



903 Copper

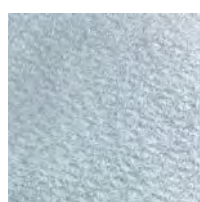

902 Silver



901 Gold

Swatches are done on:
 Dream Artist Watercolor Paper Series I
 (WCP300A4-15)



x 3 bottles



x 12 bottles

Young Artist Tempera Paint (500ml) AP 9500

KCK Young Artist Tempera Paint is a water-soluble paint that is available in a wide selection of basic, neon, glitter, pearl, and metallic range of colours. The high intensity of the colour provides excellent coverage and allows the artists to achieve fine details. Its washable, water-based formula is also suitable for children aged 3 and above because it contains no dangerous or harmful chemicals. It flows smoothly onto paper, cardboard, cloth, wood, or canvases suitable for arts and crafts projects.

Order Code	Series
AP 9500	30 COLOURS

Young Artist Tempera Paint (500ml)	Colour	Barcode
AP 9500-010	Black	8 888313 109670
AP 9500-060	White	8 888313 109687
AP 9500-102	Neon Red	8 888313 109823
AP 9500-103	Neon Orange	8 888313 109830
AP 9500-104	Neon Yellow	8 888313 109847
AP 9500-105	Neon Green	8 888313 109854
AP 9500-106	Neon Blue	8 888313 109861
AP 9500-107	Pearl Purple	8 888313 109885
AP 9500-117	Neon Pink	8 888313 109878
AP 9500-125	Pearl Green	8 888313 109892
AP 9500-126	Pearl Blue	8 888313 109908
AP 9500-132	Glitter Red	8 888313 109915
AP 9500-134	Glitter Yellow	8 888313 109922
AP 9500-135	Glitter Green	8 888313 109939
AP 9500-136	Glitter Blue	8 888313 109946
AP 9500-137	Glitter Pink	8 888313 109953
AP 9500-199	Glitter Glow-In-Dark	8 888313 109960
AP 9500-200	Red	8 888313 109694
AP 9500-300	Orange	8 888313 109700
AP 9500-400	Yellow	8 888313 109717
AP 9500-502	Sap Green	8 888313 109724
AP 9500-506	Leaf Green	8 888313 109731
AP 9500-600	Blue	8 888313 109748
AP 9500-608	Sky Blue	8 888313 109755
AP 9500-611	Purple	8 888313 109762
AP 9500-717	Pink	8 888313 109779
AP 9500-800	Brown	8 888313 109786
AP 9500-901	Gold	8 888313 109793
AP 9500-902	Silver	8 888313 109809
AP 9500-903	Copper	8 888313 109816

Code	Weight
AP 9500	11.4kg
Qty/ Carton	Measurement
48/1	30x21x20cm
Qty/ Inner	Volume
3/12	0.013m ³



**YOUNG
ARTIST**
**WASHABLE
TEMPERA
PAINT**



KCK Young Artist Acrylic Paint Set

Contains 6 x 30ml tubes
Code: AP YA830-6

KCK Young Artist Acrylic paint Set provides a basic selection of colours. The colours are vibrant and resistant to light, with the effect of a gloss finish. Each colour can easily be mixed with any other colour in the set. It is also safe for children aged 3 and above because it contains no dangerous or harmful chemicals, making it non-toxic in accordance with the EN71-3 and ASTM D-4236, European Standard, and American Standard. Suitable for arts & craft projects with paper, cardboard, or cloth.

Order	Series
AP YA830-6	KCK Young Artist Acrylic Paint Set

- ✓ Suitable for age 3 and above
- ✓ Waterproof and Fade Resistant
- ✓ Excellent Tinting Strength
- ✓ Gloss Finish
- ✓ Easy to Mix & Use
- ✓ Non-toxic and acid-free
- ✓ Suitable for Arts & Craft



Conforms to EN71-3 and ASTM D-4236

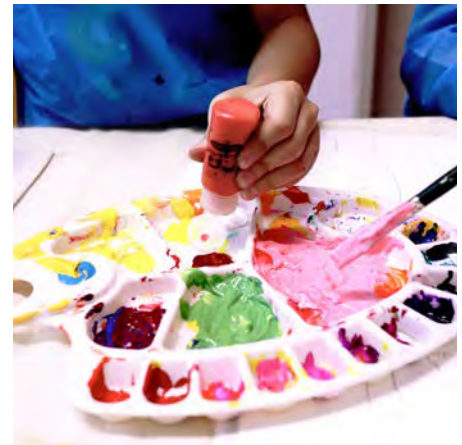

A perfect paint set for Tote Bag Painting!



KCK Poster Colour

Contains 12 x 12ml tubes
Code: AC PC1200

KCK Poster Colour is a fast-drying paint suitable for school projects, creative play, and painting drafts. The versatile characteristics of the paint allow the artists to have a thick texture by adding glue to the mix or a diluted consistency by adding water. All the colours have high colour intensity and an excellent matt finish. The paint dries fast and is safe for children above the age of 3 as it is non-toxic and acid-free.

Order	Series
AP PC1200	KCK Poster Colour (12 x 12ml tube)



- ✓ Suitable for age 3 and above
- ✓ Waterproof and Fade Resistant
- ✓ High Colour Intensity
- ✓ Highly Opaque
- ✓ Matt Finish
- ✓ Easy to Mix & Use
- ✓ Non-toxic and acid-free



Great for Finger Painting!



TOOLS & CANVASES



Introduction

Choong Marketing was established in 1998 by Mr K C Kang. We are an importer/exporter and distributor of stationery and art-based materials in Singapore. Since then, it is our company mission to supply our customers with quality products. Over the years we have grown at a steady pace; increasing product range, brand representation and channels to customers. As we continue to grow, we will continue to strengthen our position by working with partners with shared values and not forgetting our mission of providing ordinary products with extraordinary quality.

Manufacturing

We manufacture the DREAM brand in our own facilities and other than the regular selections, we can work with different customers on their own brand and specifications.

The Brands

If people are the company's right hand, the brands and partners would surely be its left hand. We value every brand we represent and it's our preference to work with brands that complement each other so that we would be able to grow in strength together. The following are brands that we represent exclusively:

•AMOS •CARIOCA •DREAM
•KANGARO •KCK QUALITY •KCK CRAFT
•KEBA KUM •MARVY UCHIDA •MONTANA CANS
•PLAY •SADIPAL •SIO-2 •KUSAKABE •SENNELIER
•PAPA CLAY •ALPHA COLOURS •YOUNG ARTIST

Contents

Pg 06-19	Brushes
Pg 20-26	Brush Sets
Pg 27-29	Brush Wallet & Brush Holder
Pg 30-36	Palettes
Pg 37-41	Brush Washer & Oil Dipper
Pg 42-55	Canvases, Canvas Clip & Portfolio Bag
Pg 56-70	Easels



121F Premium Artist Brush
C.R.A.F.T.
KCK



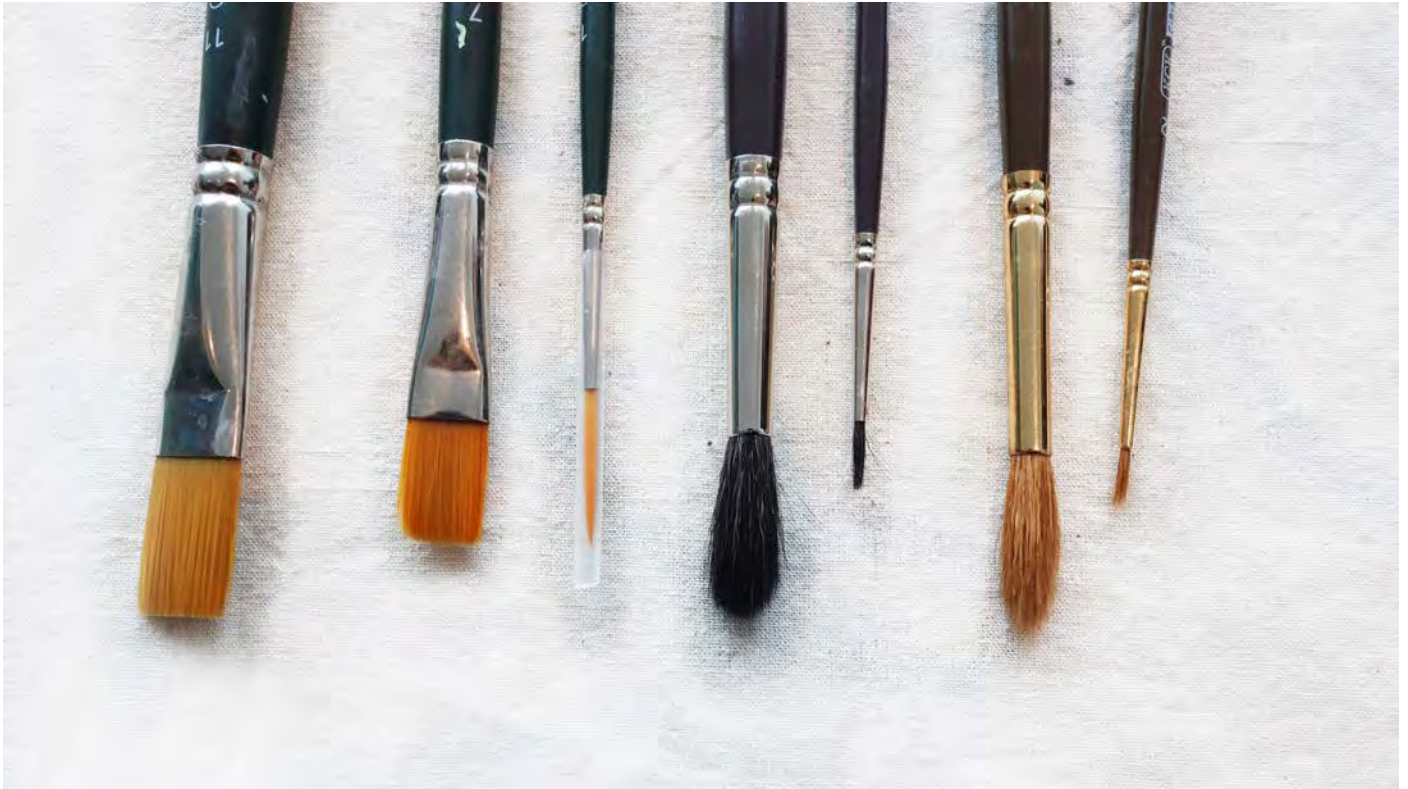

KCK Professional Artist Brushes



Doesn't clump when wet

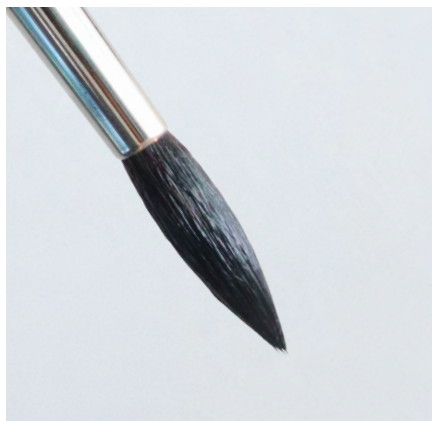

High Water-Retention



Strong Brass Plated Ferrule for easy manoeuvrability and to ensure no hair loss when painting.



Series 500 Nylon Flat Brush:

Able to withstand the transition from wet brush to dry brush due to bristles stencil strength. The Synthetic Hair is able to stay resilient and durable on many different surfaces.

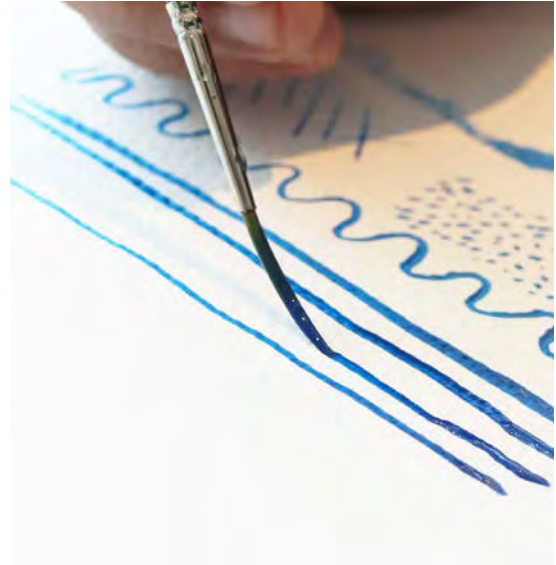

Series 600 Nylon Rigger Brush:

The long hair brush is suitable for long thin strokes and line works. The Synthetic Hair is able to stay resilient and durable on many different surfaces.



Series 800 Squirrel Pro Brush:

Due to its synthetic and natural hair combination, it has a turgid bristle structure that allows prolong usage with minimal care.

Squirrel Hair Hybrid



Series 900 Weasel Pro Brush:

It has high fluid and pigment retention that makes it one of the best professional watercolour brushes.

100% Weasel Hair



KCK Professional Artist Brushes

KCK features a range of Professional Artist Brushes for uses such as Watercolour, Acrylic and Oil. KCK Professional Nylon Brushes contains long, extra soft and springy fibres - Dedicated for higher paint-carrying capacity so that it can paint more strokes in one brush fill with easy manoeuvrability and good flow control. Nickel-Plated Ferrule to ensure no hair loss when painting.

Order Code	Series
BR 500	Brush Sizes
BR 600	Brush Sizes
BR 800	Brush Sizes
BR 900	Brush Sizes

KCK Series 500 Professional Nylon Artist Flat Brush (Series 500)



Brush Sizes (cm)	01	02	03	04	05	06	07	08	09	10	11	12
Bristle Length	0.7	1	1.1	1.25	1.45	1.65	1.7	1.95	2	2.2	2.3	2.4
Bristle Width	0.5	0.6	0.7	0.8	1	1.1	1.15	1.25	1.4	1.5	1.55	1.7
Total Length	18	18.1	18.4	18.5	18.7	19	19.4	20	20	20.1	20.5	20.9

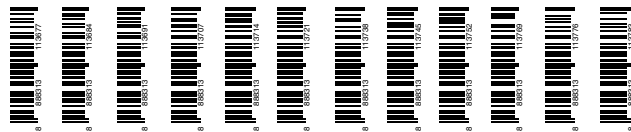

KCK Series 600 Professional Nylon Artist Rigger Brush (Series 600)



Brush Sizes (cm)	00	0	01	02
Bristle Length	1.95	2.2	2.3	2.5
Bristle Width	0.15	0.2	0.21	0.25
Total Length	18.4	18.6	19	19.2



KCK Series 800 Squirrel Professional Round Brush (Series 800)



Brush Sizes (cm)	02	04	06	08	10
Bristle Length	1	1.9	2.6	3.1	3.6
Bristle Width	0.2	0.3	0.6	0.8	1
Total Length	17.8	19.2	20.4	20.6	22

• Squirrel Hair Hybrid



KCK Series 900 Weasel Professional Round Brush (Series 900)



Brush Sizes (cm)	00	02	04	06
Bristle Length	0.6	0.9	1.75	2.6
Bristle Width	0.1	0.15	0.4	0.6
Total Length	17.2	17.8	19.4	20.4

• 100% Weasel Hair



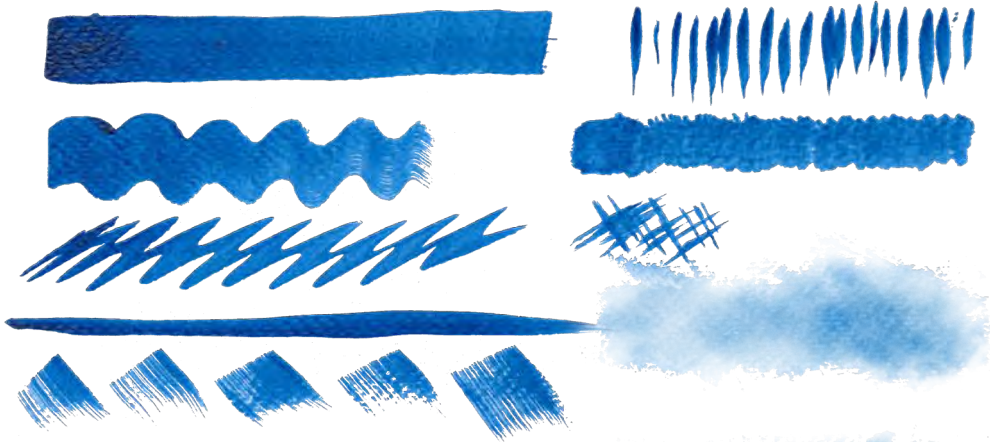

Series 500

Series 600

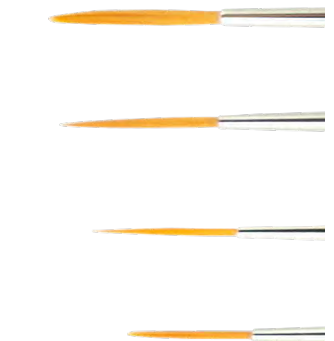

Series 800



Series 900



Swatches are done using KCK Signature Paint in Phthalocyanine Blue (AP 775-601)

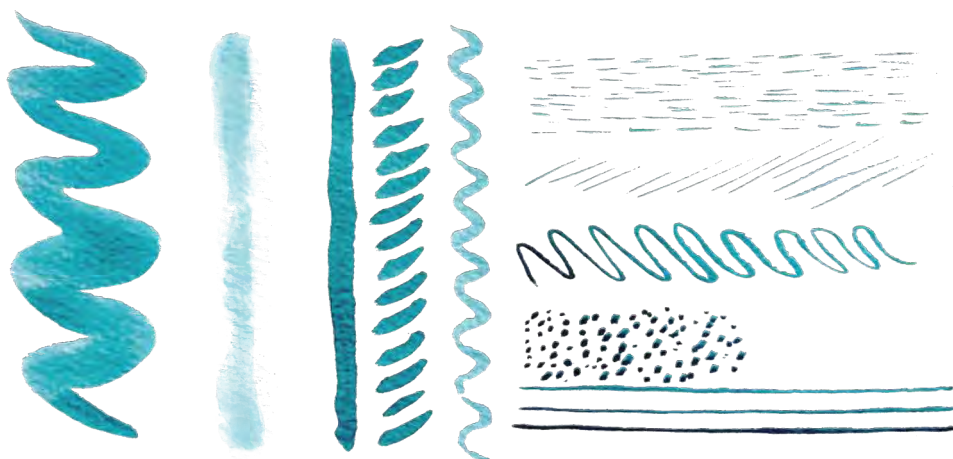
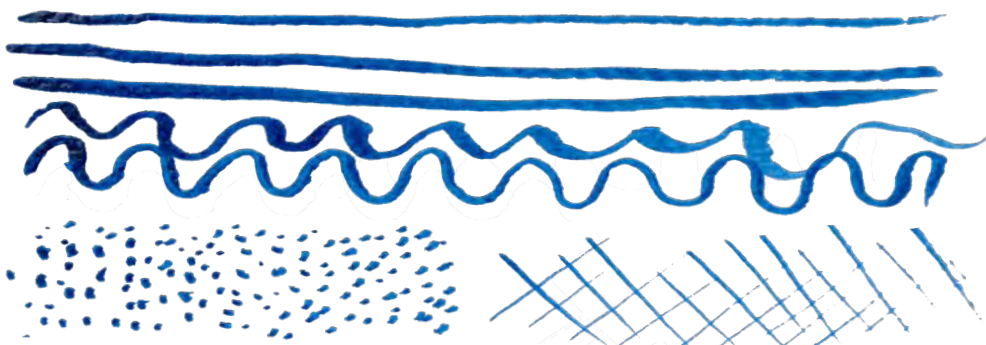

Swatches are done using KCK Watercolour Cakes - 36 Colours (SKU WC-C36)



KCK Premium Nylon Brushes (Short Handle)

KCK Premium Nylon Brushes are made with mid length and smooth synthetic bristles mounted on short wooden handles with an aluminium ferrule. This series of brushes comes in round, flat and fan brush types to fulfill your different needs whether you're looking for a delicate and round strokes or if you're working with bolder strokes. These brushes gives even paint distributions and great fluid holding ability suitable for both watercolour and acrylic painting.

Order Code	Series
BR 568F	Brush Sizes
BR 568R	Brush Sizes
BR368	Brush Sizes

KCK Nylon Studio Flat Brushes (BR 568F)



Brush Sizes (cm)	0	01	02	03	04	05	06	07	08	09	10	11	12
Bristle Length	0.8	0.9	1	1.2	1.4	1.6	1.8	2	2.1	2.3	2.5	2.7	2.9
Bristle Width	0.5	0.6	0.7	0.9	1.2	1.4	1.5	1.6	1.8	2	2.2	2.3	2.6
Total Length	19.5	20	20	21	21.3	21.7	21.7	22	22.5	23	23.5	23.5	24

KCK Nylon Studio Round Brushes (BR 568R)



medium hardness nylon bristle

aluminium-plated ferrule

Brush Sizes (cm)	00	0	01	02	03	04	05	06	07	08	09	10	11	12
Bristle Length	0.7	0.8	1	1.1	1.3	1.45	1.6	1.75	1.85	2.1	2.3	2.35	2.5	2.7
Bristle Width	0.15	0.2	0.2	0.25	0.3	0.3	0.3	0.4	0.4	0.45	0.45	0.5	0.6	0.7
Total Length	19	19.2	19.5	19.7	19.7	20.4	20.4	20.7	21	21.4	21.7	21.8	22.2	22.7

KCK Nylon Studio Fan Brushes (BR 368)



coated wooden handle (short)

Brush Sizes (cm)	01	03	05	07	09
Bristle Length	1.6	2.2	2.6	3.1	3.5
Bristle Width	3.5	5.5	6	7	8
Total Length	22	22	24.5	26.5	28.5

KCK Watercolour Brush (BR 351R)



Brush Sizes (cm)	01	02	03	04	05	06	07	08	09	10	11	12
Bristle Length	1.1	1.15	1.2	1.4	1.55	1.6	1.7	1.9	2.1	2.3	2.65	3
Bristle Width	0.2	0.25	0.3	0.3	0.3	0.4	0.5	0.5	0.5	0.6	0.6	0.7
Total Length	18.1	18.2	18.5	18.7	19.5	20	19.8	20.5	21.4	21.8	21.8	22.5

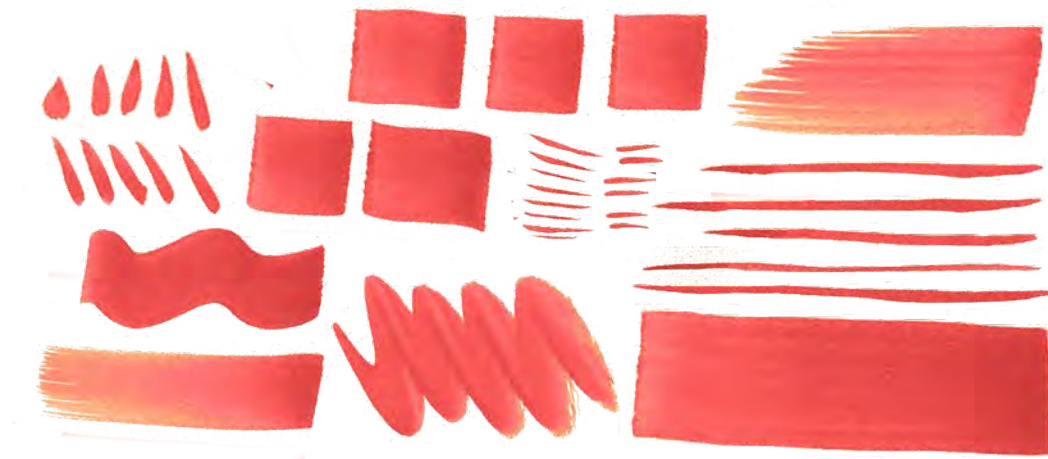

568F

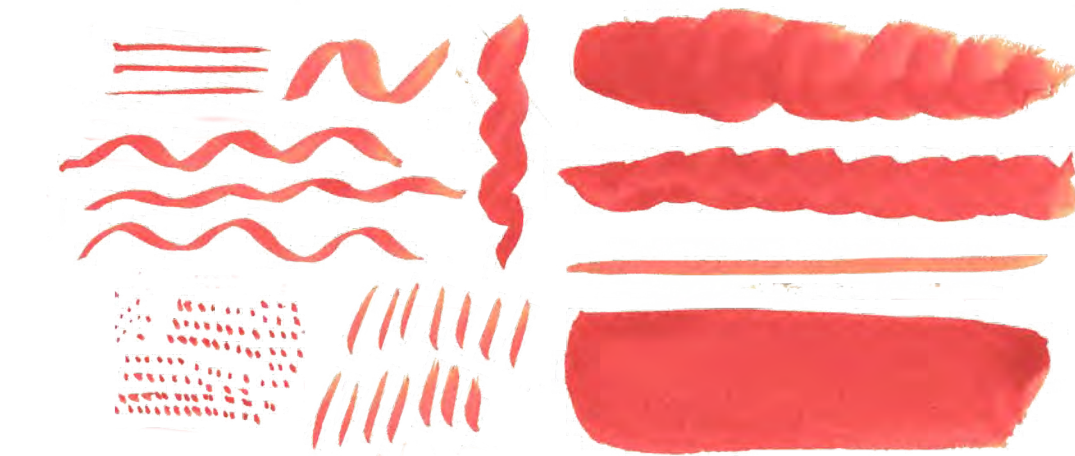

568R

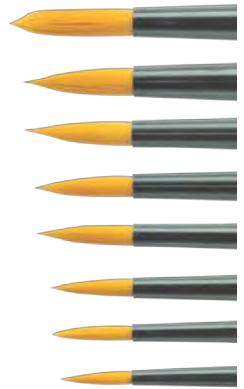

368



351R





KCK Premium Artist Brushes (Long Handle)

KCK Premium Artist Brushes is a premium quality painting brush made from hand-formed synthetic bristles that retain it's form even after multiple uses. The brush is mounted on a long handle to fulfill your different needs whether you're looking for delicate and detailed strokes or if you're working with larger areas, bolder strokes. These brushes gives even paint distributions and great fluid holding ability suitable for oil, watercolour and acrylic painting.

Order Code	Series
BR 121F	Brush Sizes
BR 121R	Brush Sizes
BR 121FR	Brush Sizes

KCK Premium Artist Flat Brush (BR 121F)



Brush Sizes (cm)	0	02	04	06	08	10	12	14	16	18	20	22	24
Bristle Length	0.7	0.7	0.9	1	1.2	1.4	1.65	1.75	1.9	2.1	2.2	2.4	2.6
Bristle Width	0.25	0.35	0.55	0.75	0.8	1.1	1.35	1.6	1.75	1.75	1.85	2.1	2.05
Total Length	28	28	28	28.5	28.9	29.5	29.9	30	30.5	31.3	30.8	31.5	32.6



KCK Premium Artist Round Brush (BR 121R)



Brush Sizes (cm)	01	02	03	04	05	06	07	08	10	12
Bristle Length	1.00	1.20	1.30	1.50	1.65	1.80	2.00	2.10	2.40	2.70
Bristle Width	0.15	0.20	0.25	0.30	0.30	0.35	0.40	0.45	0.55	0.70
Total Length	27.6	28.2	28.7	28.7	29	29.3	29.6	30.1	29.9	31.2



KCK Premium Artist Flibert Brush (BR 121FR)



Brush Sizes (cm)	0	02	04	06	08	10	12	14	16	18	20	22
Bristle Length	0.7	0.85	1.10	1.20	1.35	1.70	1.90	2.20	2.30	2.60	2.70	2.90
Bristle Width	0.30	0.35	0.50	0.60	0.80	1.00	1.30	1.40	1.60	1.70	1.80	2.00
Total Length	27.7	28.2	28.6	29	29	30	29.7	30	30.8	32	31.4	31.9



I21F

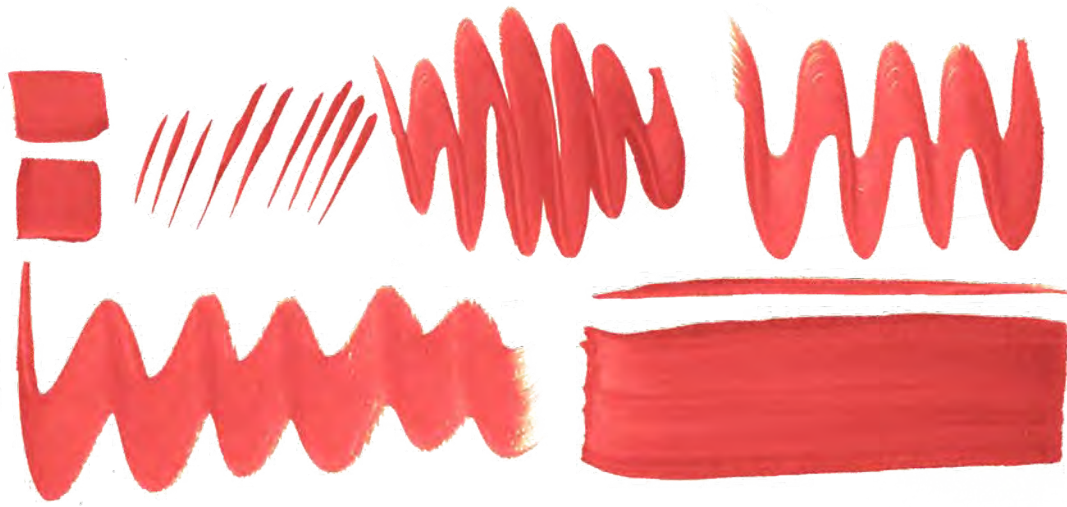

I21R

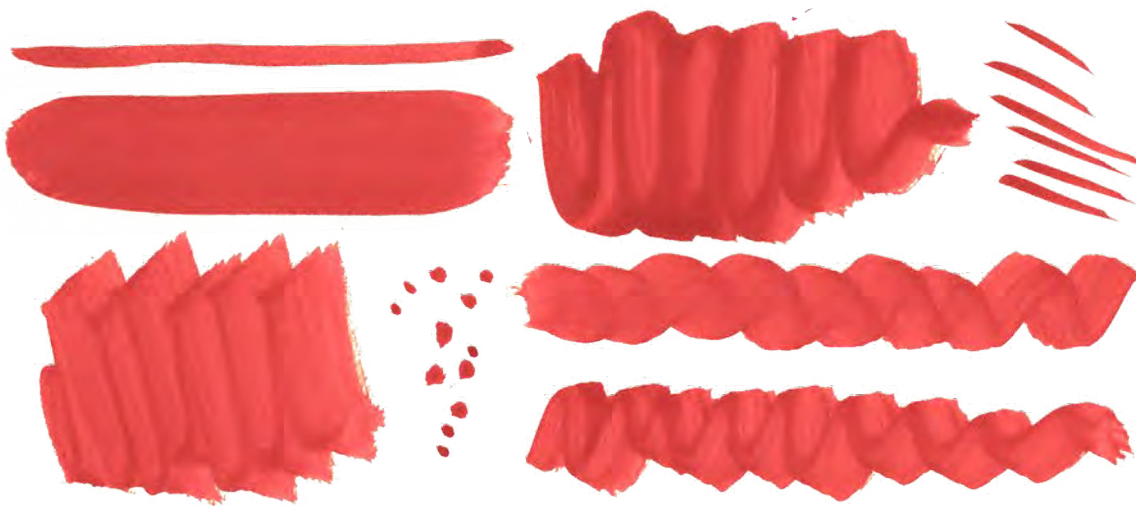

I21FR





KCK Bristle Brushes (Hog Hair)

The BR679 Bristle Brushes are academic brushes that is designed with durable and quality hog hair bristles, a rust-resistant aluminium plated ferrule, fitted with a classic wooden handle finish. Comes in a set of 6, either flat or round brushes. Suitable for beginner or casual painters and works well with acrylic and oil paint.

Order Code	Series
BR 679F	Brush Sizes
BR 679R	Brush Sizes
BR 468FR	Brush Sizes

KCK Bristle Long Handle Flat Brush (BR 679F)



Brush Sizes (cm)	01	02	03	04	05	06	07	08	09	10	11	12
Bristle Length	0.85	1.15	1.20	1.60	1.75	1.90	2.10	2.20	2.40	2.55	3.10	3.30
Bristle Width	0.40	0.45	0.50	0.70	0.80	1.00	1.20	1.30	1.50	1.70	1.90	2.00
Total Length	28	28.8	29	35	32	34	32	32	32.3	33.4	34.4	34.3

KCK Bristle Long Handle Round Brush (BR 679R)



Brush Sizes (cm)	01	02	03	04	05	06	07	08	09	10	11	12
Bristle Length	1.00	1.30	1.50	2.00	1.90	2.10	2.40	2.80	3.00	3.50	4.00	4.30
Bristle Width	0.40	0.50	0.55	0.70	0.80	0.90	1.00	1.10	1.20	1.50	1.80	2.20
Total Length	28.6	29.5	29.5	29.7	29.5	29.9	32.1	31.8	36	36.5	40	35.5

KCK Short Handle Young Artist Stencil Brush (BR 468S)



Brush Sizes (cm)	02	04	06	08	10
Bristle Length	1.00	1.40	1.80	2.20	2.60
Bristle Width	0.60	0.80	1.00	1.20	1.70
Total Length	13.8	14.5	16.2	16.4	16.7



KUM Short Handle Borsten Pincel Flach Brush (BR KU1)



Brush Sizes (cm)	02	04	06	08	10	12	14	16
Bristle Length	0.65	0.80	0.95	1.10	1.30	1.50	1.80	2.00
Bristle Width	0.30	0.45	0.80	0.90	1.10	1.30	1.50	1.80
Total Length	16.7	16.4	17.5	17.3	17.4	18.2	19	20.5



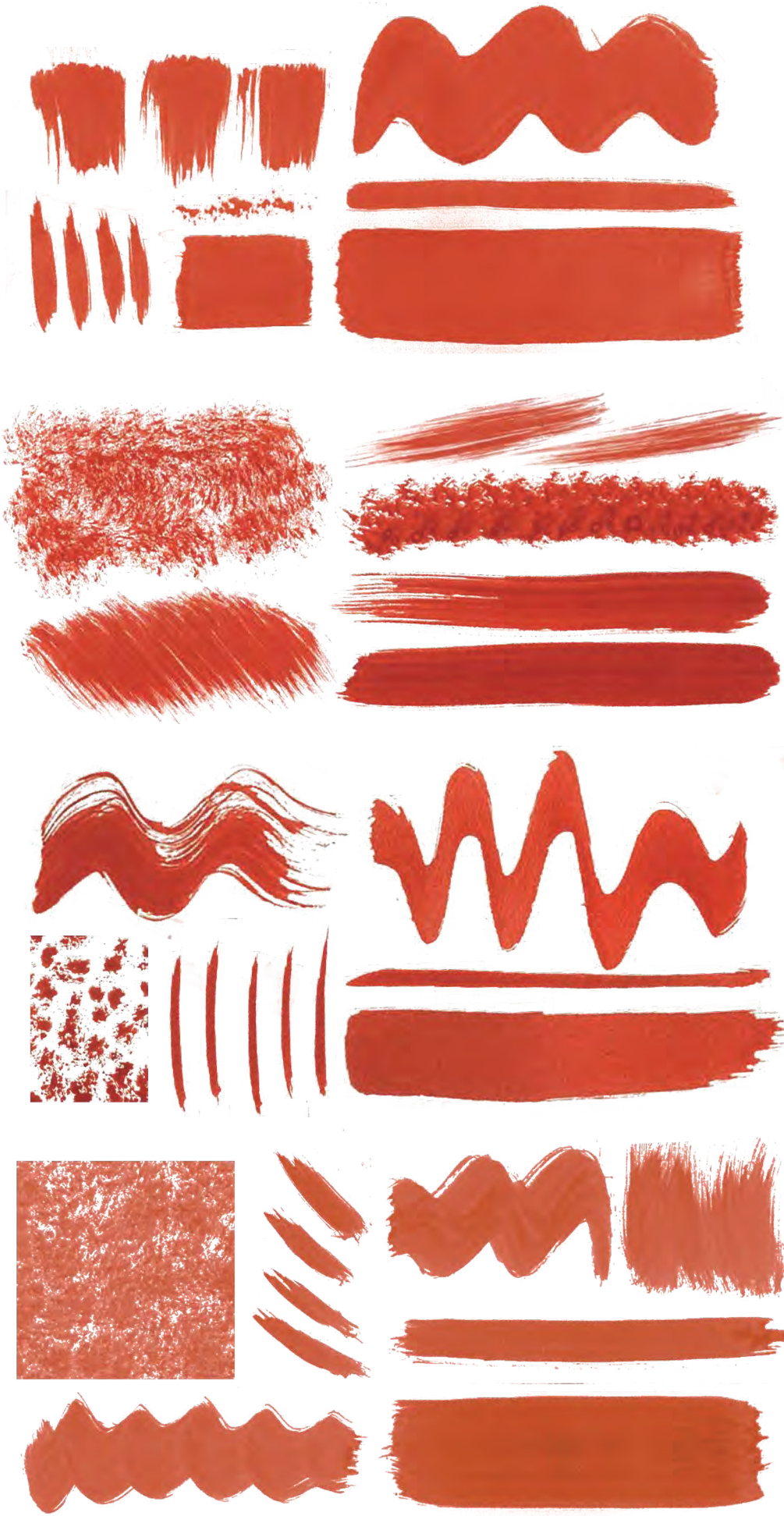

679F



679R



468S



KUI





KCK Hake Brushes

Hake brushes are wide bristled brush that are fitted with durable and quality hog hair bristles, nickel plated ferrule and a flat wooden handle to enable controlled handling of the wide brush. Primarily used as a priming brush, the Hake brush offers good liquid retention and deposition to ensure consistent even coating. Comes in both long & short handle.

Order Code	Series
BR 868	Brush Sizes
BR 968	Brush Sizes
BR 768	Brush Sizes

KCK Long Handle Hake Brush (BR 868)

- Great for priming with gesso.
- Made up of Hog Hair.



Brush Sizes (cm)	01	03	05
Bristle Length	4	4.7	5.5
Bristle Width	3	5	7
Total Length	31.7	35.5	40



KCK Short Handle Hake Brush (BR 968)

- Great for glazing, priming and paint washing.
- Made up of Goat Hair.



Brush Sizes (cm)	0.5	01	1.5	02	Goat Hair
Bristle Length	2.5	2.6	2.9	3.2	
Bristle Width	2	2.5	3.5	4.5	
Total Length	17.6	18.4	19.5	20	



KCK Art Mottler Brush (BR 768)



- Can be used for paint washing, varnishing, and priming.
- Mostly for Watercolour.



Brush Sizes (cm)	03	05	07
Bristle Length	4.1	4.1	4.1
Bristle Width	2.5	5.0	7.5
Total Length	20.1	21.6	23.1



Mottler brush is a wide bristled brush that is fitted with synthetic nylon bristles, a rust-resistant nickel-plated ferrule, and an ergonomic flat wooden handle coated with a protective layer of paint. Primarily a priming brush, the Mottler brush could also be used as a secondary brush for bigger-sized paintings as it offers good liquid retention and deposition to ensure a consistent even coating.

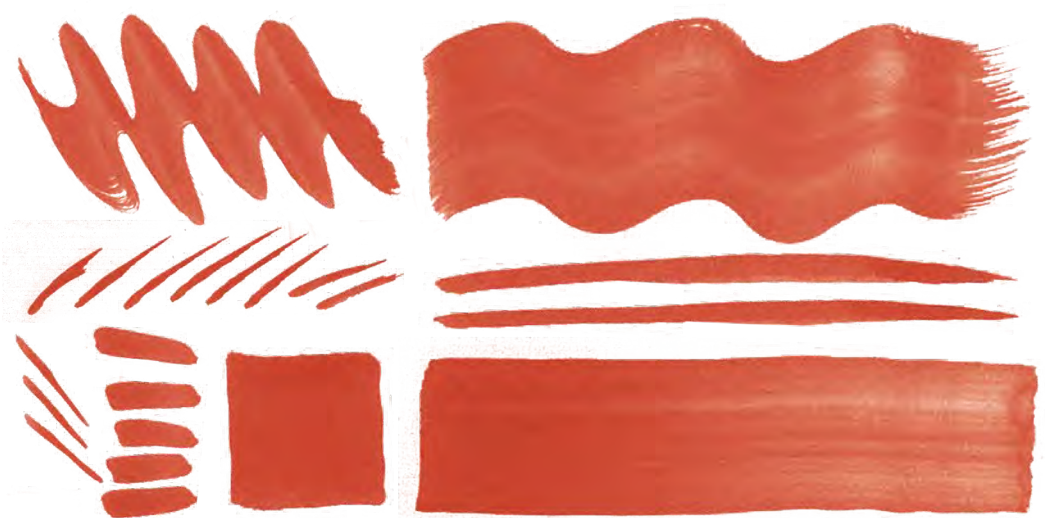

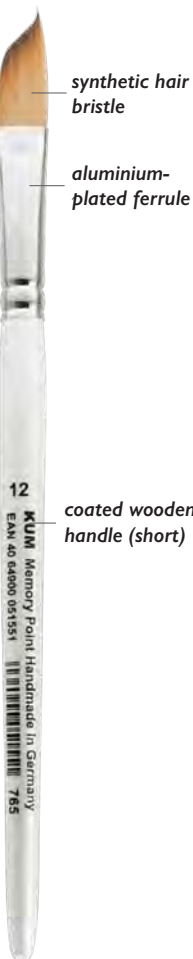

KUM Short Handle Memotip Brushes

KUM Memory Point high-tech hairs have been specially developed for KUM. Made from premium nylon bristles, the Memory Point Brush has a perfectly shaped brush tip. This makes it possible to paint the smallest and intricate details. The fine tips return to its original shape due to its elastic property. The short handle and smooth round surface makes it comfortable to hold.

Order Code	Series
BR KUMTF	Brush Sizes
BR KUMTR	Brush Sizes
BR KUMTCT	Brush Sizes
BR KUMTSL	Brush Sizes

KUM Memotip Flat Brush (BR KUMTF)



Brush Sizes (cm)	02	04	06	08	10	12	14	16	18	22	24
Bristle Length	0.75	0.8	1.1	1.15	1.2	1.1	1.8	2	2.2	2.35	2.3
Bristle Width	0.4	0.5	0.7	0.9	0.25	1.2	1.35	1.5	1.7	1.9	2.2
Total Length	17	17.1	17.9	17.75	19.7	19.7	19.3	20.1	21.3	21.7	21.6



KUM Memotip Round Brush (BR KUMTR)



Brush Sizes (cm)	0000	00	0	01	02	03	04	05	06	07	08	09	10	11	12	14
Bristle Length	0.55	0.7	0.85	0.95	1.1	1.25	1.45	1.75	1.85	2	2.15	2.25	2.5	2.7	2.8	3
Bristle Width	0.1	0.15	0.2	0.2	0.25	0.3	0.3	0.35	0.45	0.55	0.6	0.65	0.7	0.75	0.85	0.85
Total Length	16.4	16.8	16.5	16.4	17.1	17.5	17.5	18	18.2	18.8	18.8	18.8	19.7	20.6	20.8	20.8

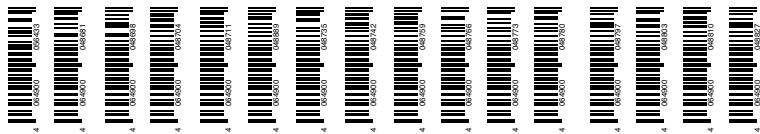

KUM Memotip Cat-Tongue Brush (BR KUMTCT)

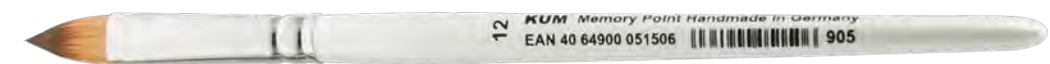

Brush Sizes (cm)	06	08	10	12	14
Bristle Length	1.2	1.45	1.95	1.65	2.3
Bristle Width	0.6	0.8	1.1	1	1.3
Total Length	17.5	17.9	19.7	19.85	24



KUM Memotip Slant Brush (BR KUMTSL)

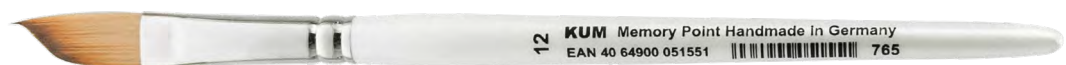

Brush Sizes (cm)	06	08	10	12	14
Bristle Length	2	2.15	2.65	2.95	3.13
Bristle Width	0.6	0.9	1.1	1.3	1.4
Total Length	18.1	18.7	19.7	20.7	21.2



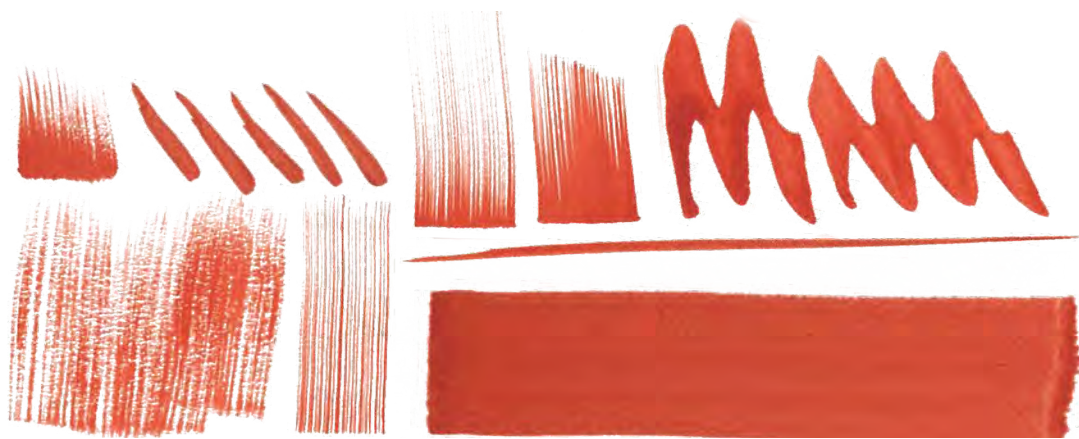

KUMTF

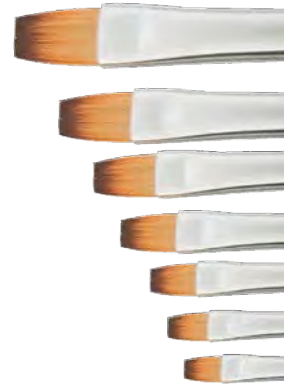

KUMTR



KUMTCT



KUMTSL

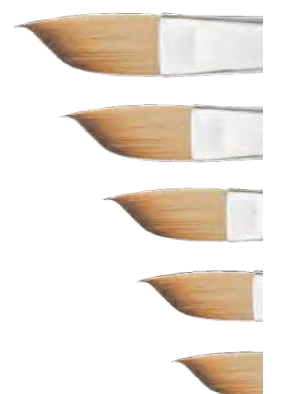



KCK Short Handle Nylon Artist Brush Sets

Suitable for beginners, students and artists who are on a economical budget. It delivers and performs well due to it's great paint distribution and fluid holding ability. The nylon brush set contains basic primary brushes suitable for round delicate brush strokes or big bold strokes. The short handle brushes gives you the ability to control the texture of the painting due to its aluminium plated ferrule.

Order Code

- BR T2-01**
- BR T2-02**
- BR T2-03**
- BR T2-04**



- **Flat Brush**
- Sizes 2,4,6

Brush Set BR T2-01
*Suitable For Small & Intricate Details



- **Flat Brush**
- Sizes 1/4, 1/2, 1

Brush Set BR T2-03
*Suitable For Large Areas

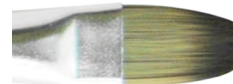

- **Flat Brush**
- Sizes 6,12

- **Round Brush**
- Sizes 6,8

- **Flibert Brush**
- Sizes 8

Brush Set BR T2-02
*Basic All-In-One Set



- **Liner Brush**
- Size 2

- **Dagger Striper Brush**
- Size 6



- **Fan brush**
- Size 2

Brush Set BR T2-04
*Suitable For Texture





KCK Short Handle Golden Nylon Brush Sets

Suitable for beginners, students and artists who are on an economical budget. This Brush Set has a higher paint-carrying capacity so that it can paint more strokes in one brush fill. The nylon brush set contains 2 different ranges of brushes - 1 Flat Brush Set & 1 Round Brush Set. The short handle brushes and it's aluminium plated ferrule are made proportioned to balance in the hand and to give optimum control when painting.

Order Code

BR A100

BR A200



Brush Set (Round) BR A100

- Round Brush
- Sizes 4,8,12

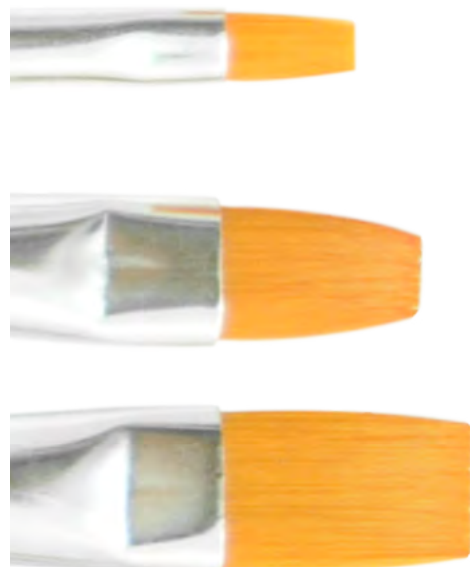

Brush Set (Flat) BR A200

- Flat Brush
- Sizes 4,8,12





KCK Artist Short Handle Golden Brush Sets

The KCK Short Handle, Golden Nylon Brush Sets are fine nylon bristled brushes equipped with artist grade, hand-formed, short handle with aluminium plated ferrule and a sturdy polished wooden handle. Comes in various convenient-set of 3 brushes with different combination of brushes to allow one to do fine detailing and general painting. Performs well with oil, acrylic, watercolour, gouache and other fine arts medium.

Order Code

BR SB01	BR SB02
BR SB03	BR SB04
BR SB05	BR SB06



BR SB01

- Flat & Round Brush
- Flat Brush: Sizes 10,18
- Round Brush: Size 0,8



BR SB02

- Flat & Round Brush
- Flat Brush: Sizes 2,8
- Round Brush: Size 6,12



BR SB03

- Round, Slant & Fan Brush
- Round Brush: Sizes 2/0,1,10/0
- Slant Brush: Sizes 1/8
- Fan Brush: Size 2/0





KCK Artist Short Handle Golden Brush Sets

The KCK Short Handle, Golden Nylon Brush Sets are fine nylon bristled brushes equipped with artist grade, hand-formed, short handle with aluminium plated ferrule and a sturdy polished wooden handle. Comes in various convenient-set of 3 brushes with different combination of brushes to allow one to do fine detailing and general painting. Performs well with oil, acrylic, watercolour, gouache and other fine arts medium.

Order Code

BR SB01	BR SB02
BR SB03	BR SB04
BR SB05	BR SB06



BR SB04

- Flat & Round Brush
- Flat Brush: Sizes 2,6,1/2,3/4
- Round Brush: Size 0,4,8,12



BR SB05

- Flat & Round Brush
- Flat Brush: Sizes 2,6,1/2
- Round Brush: Size 1,3,5



BR SB06

- Flat, Round, Slant & Filbert Brush
- Flat Brush: Sizes 8,3/4
- Round Brush: Sizes 1,2,6
- Slant Brush: Size 1/4
- Filbert Brush: Size 4





KCK Artist Short Handle Golden Brush Sets

The KCK Short Handle, Golden Nylon Brush Sets are fine nylon bristled brushes equipped with artist grade, hand-formed, short handle with aluminium plated ferrule and a sturdy polished wooden handle. Comes in various convenient-set of 3 brushes with different combination of brushes to allow one to do fine detailing and general painting. Performs well with oil, acrylic, watercolour, gouache and other fine arts medium.

Order Code

- BR SH01 BR SH02 BR SH03
 BR SH04 BR SH05 BR SH06
 BR SH07 BR SH08 BR SH09



BR SH01

- Flat Brush
- Sizes 2,4,6



BR SH02

- Flat Brush
- Sizes 3,7,9



BR SH03

- Flat Brush
- Sizes 0,1,5,8



BR SH04

- Round Brush
- Sizes 4,8,12





KCK Artist Short Handle Golden Brush Sets

The KCK Short Handle, Golden Nylon Brush Sets are fine nylon bristled brushes equipped with artist grade, hand-formed, short handle with aluminium plated ferrule and a sturdy polished wooden handle. Comes in various convenient-set of 3 brushes with different combination of brushes to allow one to do fine detailing and general painting. Performs well with oil, acrylic, watercolour, gouache and other fine arts medium.

Order Code

- BR SH01 BR SH02 BR SH03
- BR SH04 BR SH05 BR SH06
- BR SH07 BR SH08 BR SH09



BR SH05

- Round Brush
- Sizes 00, 1, 7, 11

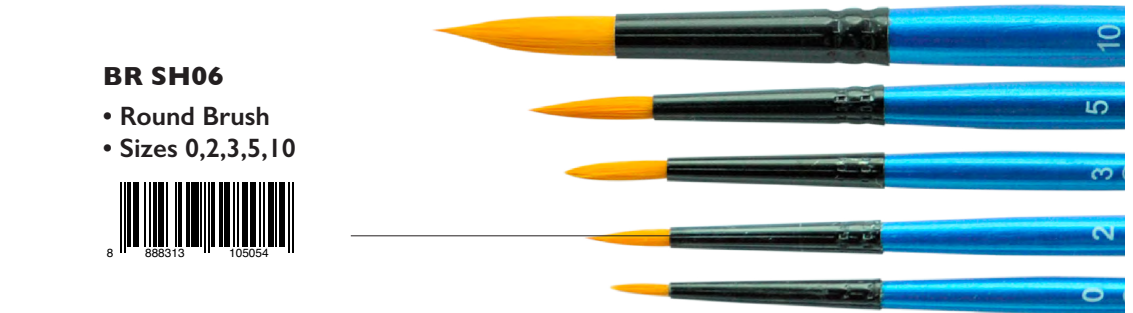

BR SH06

- Round Brush
- Sizes 0, 2, 3, 5, 10



BR SH07

- Round Brush
- Sizes 00, 5, 7

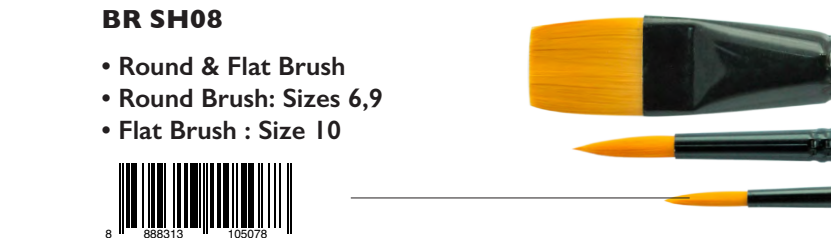

BR SH08

- Round & Flat Brush
- Round Brush: Sizes 6, 9
- Flat Brush : Size 10



BR SH09

- Round, Flat & Fan Brush
- Round Brush: Sizes 3, 7
- Flat Brush: Size 5
- Fan Brush: Size 1





KCK Premium Artist Long Handle Brush Sets

The BR121 are premium nylon bristled brushes equipped with artist grade, hand-formed, fine nylon bristles, secured with a rust-resistant nickel plated ferrule and a sturdy polished wooden handle. Comes in various convenient-set of 3-6 brushes with different combination of brushes to allow one to do fine detailing and general painting. Performs well with oil, acrylic, watercolour, gouache and other fine arts medium. The set gives you the ability to control the texture of the painting due to its aluminium plated ferrule. It also gives the ability to control the intensity of the brush strokes due to its long handle.

Order Code

BR LH01 BR LH02 BR LH03

BR LH04 BR LH05 BR LH06

BR LH07 BR LH08 BR LH09

BR LH10 BR LH11 BR LH12



BR LH01
 • Flat Brush
 • Sizes 2,6,10



BR LH02
 • Flat Brush
 • Sizes 12,16,20



BR LH03
 • Flat Brush
 • Sizes 0,6,1,4,20



BR LH04
 • Round Brush
 • Sizes 2,4,8



BR LH05
 • Round Brush
 • Sizes 6,10,12



BR LH06
 • Flat & Round Brush
 • Round Brush: Sizes 2,6,12
 • Flat Brush: Size 24





KCK Premium Artist Long Handle Brush Sets

The BR121 are premium nylon bristled brushes equipped with artist grade, hand-formed, fine nylon bristles, secured with a rust-resistant nickel plated ferrule and a sturdy polished wooden handle. Comes in various convenient-set of 3-6 brushes with different combination of brushes to allow one to do fine detailing and general painting. Performs well with oil, acrylic, watercolour, gouache and other fine arts medium. The set gives you the ability to control the texture of the painting due to its aluminium plated ferrule. It also gives the ability to control the intensity of the brush strokes due to its long handle.

Order Code

BR LH01 BR LH02 BR LH03

BR LH04 BR LH05 BR LH06

BR LH07 BR LH08 BR LH09

BR LH10 BR LH11 BR LH12



BR LH07

- Flibert Brush
- Sizes 2,6,10



- ### BR LH08
- Flibert Brush
 - Sizes 14,18,22



BR LH10

- Flat & Round Brush
- Flat Brush: Sizes 0,10,14
- Round Brush: Size 4,10



BR LH09

- Flat & Round Brush
- Flat Brush: Sizes 0,6,18
- Round Brush: Size 2,6



BR LH11

- Flat, Round & Flibert Brush
- Flat Brush: Sizes 2,6
- Flibert Brush: Sizes 6,10
- Round Brush: Size 4,8



BR LH12

- Flat, Round & Flibert Brush
- Round Brush: Size 12
- Flibert Brush: Size 14
- Flat Brush: Size 16





KCK Academic Bristle Long Handle Brush Set (Hog Hair) 

The BR679 Bristle Brushes are academic brushes that is designed with durable and quality hog hair bristles, a rust-resistant aluminium plated ferrule, fitted with a classic wooden handle finish. Comes in a set of 6, either flat or round brushes. Suitable for beginner or casual painters and works well with acrylic and oil paint.

Order Code

BR 679F - 6A BR 679R - 6A

BR 679F - 6B BR 679R - 6B



Brush Sets are in Economical pack of 6.

Versatile & Durable.

Suitable for beginners or artists.



BR 679F-6A (Odd)

- Flat Brush
- Sizes 1,3,5,7,9,11



BR 679F-6B (Even)

- Flat Brush
- Sizes 2,4,6,8,10,12



BR 679R-6A (Odd)

- Round Brush
- Sizes 1,3,5,7,9,11



BR 679R-6B (Even)

- Round Brush
- Sizes 2,4,6,8,10,12





KCK Non-Woven Brush Bag - HC BB266

Suitable for short-handle brushes. It has 12 Brush Slots to accommodate about 20+ painting brushes of different sizes. 1 Brush Slot can accommodate 2 big-sized brushes or 4 thin brushes. A layer of non-woven fabric is also used for the pouch's flap to protect the brush hair from grazing against each other. This non-woven brush bag is waterproof, moisture-proof, easily washable, and also resilient, making it one of KCK's durable brush bags.

Order Code	Colour
BB266BL	Blue
BB266RD	Red
BB266TQ	Turquoise
BB266YL	Yellow



Available in Red, Yellow, Turquoise & Blue

•12 Compartments

•1 Slot could fit 2 big-sized brushes or 4 thin brushes. A total of 20+ Brushes are able to fit in this Brush Bag

•Pouch Flap

•Protects the brushes kept in the compartments from getting grazed with other materials during safe-keeping

•Non- Woven Fabric:

•This easily washable and waterproof brush bag can tolerate water and moisture from the paintbrushes due to it's non-woven fabric property

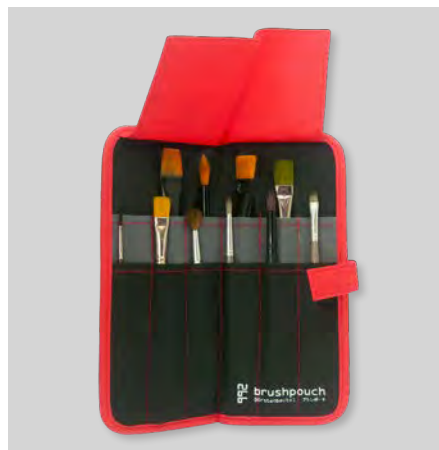
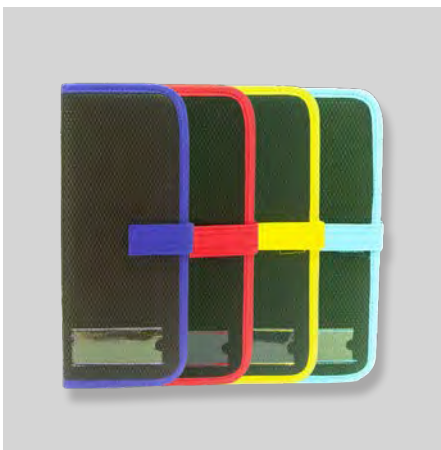

For Short-Handle Brushes



Velcro Straps





KCK Brush Bag/Holder - HC BB30

Suitable for both long & short handle brushes. It has 10 Brush Slots to accommodate about 20+ painting brushes of different sizes. The Cord Locks Stopper with a drawstring holds up the brush bag and the brushes in an upright position for easy usage when painting. The portable holder with stretchy slots is ideal for on-the-go painter or at home/studio usage.

Order Code

HC BB30



Standing Mode

3-in-1 Modes

•Compact Mode:

•The bag could be folded into halves for storing. Each bag comes with a labelling holder for your labelling needs.

•Layout Mode:

•The bag could be laid out flat on any surface. This gives you a good view of what brushes you have and make it easier for you to arrange them.

•Standing Mode:

•The bag could be turned into a brush stand instantly with the pull of a knob. This is the best mode to use while you are painting.



Compact Mode



Layout Mode





Wooden Palettes



KCK Wood Palette - MDF

- **Made from MDF** (Medium Density Fibreboard)
- **Thumb Hole**
- **Suitable for Oil & Acrylic**
- *The palette should not be washed or soaked directly in water but wiped with a damp cloth instead*

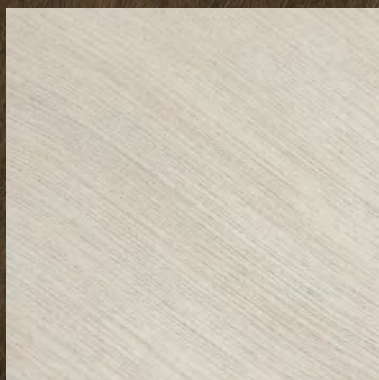

Order Code	Article Number	Size
	WD KPL2030-03	20cm x 30cm - 0.3mm
	WD KPL2430-03	24cm x 30cm - 0.3mm
	WD KPL2430-05	24cm x 30cm - 0.5mm
	WD KPL3040-05	30cm x 40cm - 0.5mm
	WD KPL4050-05	40cm x 50cm - 0.5mm

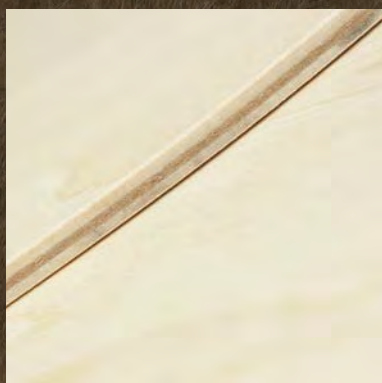

KCK Wood Palette - Plywood

- **Made from Plywood**
- **Thumb Hole**
- **Suitable for Oil & Acrylic**
- *The palette should not be washed or soaked directly in water but wiped with a damp cloth instead*



Order Code	Article Number	Size
	WD EPL2430-05	24cm x 30cm - 0.5mm
	WD EPL3040-05	30cm x 40cm - 0.5mm
	WD EPL4050-05	40cm x 50cm - 0.5mm





Plastic Palettes (Versatile)



Plastic Palette

- 6 Wells & 4 Mixing Areas
- Thumb Hole
- Suitable for Watercolour & Acrylic
- Easy to Clean

Order Code	Article Number	Size
	HC P2205	7 x 9inch



Artist Plastic Palette

- 12 Wells & 5 Mixing Areas
- 3 Brush holders
- Thumb Hole
- Suitable for Watercolour & Acrylic
- Easy to Clean

Order Code	Article Number	Size
	HC 3013	25 x 35cm



Plastic Palette

- 9 Wells
- Thumb Hole
- Suitable for Watercolour & Acrylic
- Easy to Clean

Order Code	Article Number	Size
	HC P2204	8.5x 11.5inch



Plastic Palettes (Versatile)



Plastic Palette Round

- 11 Wells
- Suitable for Watercolour & Acrylic
- Easy to Clean



Order Code	Article Number	Size
	HC P2206	Dia - 17cm



Watercolour Palette

- 13 Wells
- Suitable for Watercolour & Acrylic
- Easy to Clean



Order Code	Article Number	Size
	WC D808	19.7cm



Watercolour Palette Boxes



Plastic Mixing Box

- 24 Wells
- Suitable for Watercolour & Acrylic
- Easy to Clean

Order Code	Article Number	Size
	HC P2208	-



Plastic Palette for Acrylic

- 11 Wells
- Suitable for Watercolour & Acrylic
- Easy to Clean

Order Code	Article Number	Size
	HC P2207	15 x 31cm

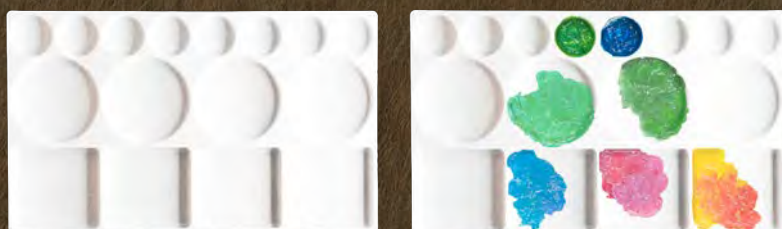

Acrylic Paint Plastic Palette

- 16 Wells
- Suitable for Watercolour & Acrylic
- Easy to Clean

Order Code	Article Number	Size
	HC P2209	16.4 x 27cm



Watercolour Palette Boxes



Watercolour Palette Box

- 16 Wells & 5 Mixing Areas
- 3 Brush holders
- Thumb Hole
- Suitable for Watercolour & Acrylic
- Easy to Clean

Order Code	Article Number	Size
	HC P2200	10 x 20cm



Watercolour Palette Box

- 16 Wells & 5 Mixing Areas
- 3 Brush holders
- Thumb Hole
- Suitable for Watercolour & Acrylic
- Easy to Clean

Order Code	Article Number	Size
	HC P2210	11 x 25.5cm



Watercolour Palette Box

- 16 Wells & 5 Mixing Areas
- 3 Brush holders
- Thumb Hole
- Suitable for Watercolour & Acrylic
- Easy to Clean

Order Code	Article Number	Size
	HC P2211	14 x 30.5cm



Foldable Wash Tub



Foldable Wash Tub + Sponge (Big)

- Foldable Wash Tub for On-the-go painters
- Sponge to clean excess water/paint on the paint brush while painting
- Sponge can also be used to clean tub or brushes after painting

Order Code	Article Number	Size
	HC 3011	14x10cm

Foldable Wash Tub + Sponge (Small)



- Foldable Wash Tub for On-the-go painters
- Sponge to clean excess water/paint on the paint brush while painting
- Sponge can also be used to clean tub or brushes after painting

Order Code	Article Number	Size
	HC 3010	10x8cm



Plastic Wash Tub



Wash Tub + Palette Set

- 11 Wells
- 15 Brush Holders (Varied Sizes)
- 2 Washing Areas (Layered Bottom)
- Suitable for Watercolour & Acrylic
- Easy to Clean

Order Code	Article Number	Size
	HC WT1317	16x9cm

Wash Tub Square + Palette Set



- 4 Wells & 1 Mixing Area
- 24 Brush Holders (Varied Sizes)
- 2 Washing Areas (Layered Bottom)
- Suitable for Watercolour & Acrylic
- Easy to Clean

Order Code	Article Number	Size
	HC WT1616	16x16x9cm



Metal Brush Washers



Metal Brush Washer + Cap

- Strainer provides a surface to clean and dry paint brushes
- Removable Air-tight Lids to prevent liquid overflow
- Stainless Steel & Non-corroding
- Suitable for Oil, Watercolour & Acrylic

Order Code	Article Number	Size
	HC MT0809	7 x 9 cm



Metal Brush Washer + Hanger

- Strainer provides a surface to clean and dry paint brushes
- A Hanger that holds paintbrushes
- Metal Ridges to collect excess paint on brush
- Stainless Steel & Non-corroding
- Suitable for Oil, Watercolour & Acrylic

Order Code	Article Number	Size
	HC MT1012	9 x 20cm



palette
L'ESSENCE DU CAFE

RCK



KCK Oil Dipper Single

KCK Oil Dipper comes in a single and double pot with a clip underneath that can easily be slid onto the edge of a palette while remaining tight enough to keep dipper securely in place. Made from metallic silver metal, the tight lid ensures that the pot does not spill any excess liquid. Suitable for storing and painting mediums such as turpentine, linseed oil and gel mediums. The lids gives an extra surface to mix mediums and paints together.

Order Code	Size
HC F335-1	Single
HC F334-2	Double



HC F335-1
Oil Dipper Single
4 x 3cm (W x Hcm)



8 888313 103050



HC F334-2
Oil Dipper Double
9 x 3cm (W x Hcm)



8 888313 103067



KCKTM
C.R.A.F.T.

stretched
canvases

Quality
Improvement



KCKTM
C.R.A.F.T.

stretched
Artist canvases

Back-Stapled 100% Cotton Pine Wood

380g/m²

Size
12x16 Inch
30x41cm

Acrylic triple gesso primed
Suitable for oil and acrylic
Medium texture
Acid-free



KCK Stretch Artist Canvas 3/4 Inch (100% Cotton)

The KCK Canvas offers a 380g/m² medium weight cotton fabric that is triple primed with a neutral white gesso, stretched over a sturdy pine wood frame and secured with back staples. Available in the classic 3/4 inch and in different dimensions of canvases which offers versatility to usage. Suitable for oil and acrylic paint.



3/4 Inch



380 g/m²

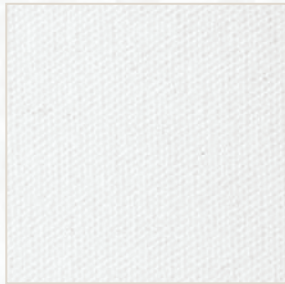

medium texture grain, primed with three layers of gesso

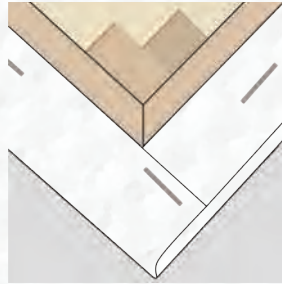

corner tightening wedges to increase tautness when and if needed

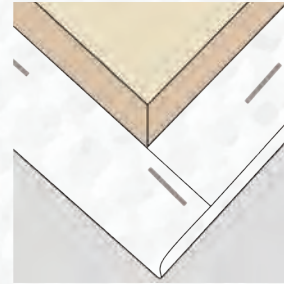

all the canvases are back-stapled, with a pine wood frame

Barcode	Article Number	Size
	CV C0404-075	4"x4"
	CV C0507-075	5"x7"
	CV C0606-075	6"x6"
	CV C0709-075	7"x9"
	CV C0808-075	8"x8"
	CV C0810-075	8"x10"
	CV C0812-075	8"x12"
	CV C0912-075	9"x12"
	CV C1012-075	10"x12"
	CV C1014-075	10"x14"
	CV C1114-075	11"x14"
	CV C1212-075	12"x12"
	CV C1216-075	12"x16"
	CV C1224-075	12"x24"
	CV C1236-075	12"x36"
	CV C1418-075	14"x18"
	CV C1620-075	16"x20"

Barcode	Article Number	Size
	CV C1624-075	16"x24"
	CV C1818-075	18"x18"
	CV C1824-075	18"x24"
	CV C1836-075	18"x36"
	CV C2020-075	20"x20"
	CV C2024-075	20"x24"
	CV C2030-075	20"x30"
	CV C2424-075	24"x24"
	CV C2430-075	24"x30"
	CV C2436-075	24"x36"
	CV C2448-075	24"x48"
	CV C3030-075	30"x30"
	CV C3040-075	30"x40"
	CV C3535-075	35"x35"
	CV C3648-075	36"x48"

Quality
Guaranteed

Size
12x16 inch
30x41cm

Soft stretched canvases

||| C·R·A·F·T |||
KCK
TM

15x20 inch
38x51cm

KCK
CRAFT



KCK Stretch Artist Canvas 1.5 Inch (100% Cotton)

The Acid-Free KCK Canvas offers a 380g/m² medium weight cotton fabric that is triple primed with a neutral white gesso, stretched over a sturdy pine wood frame and secured with back staples. Available in the classic 3/4 inch and in different dimensions of canvases which offers versatility to usage. Suitable for oil and acrylic paint.

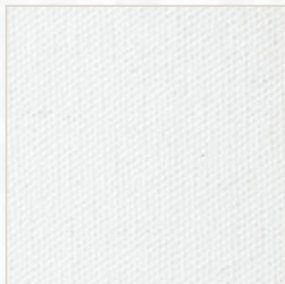

medium texture grain, primed with three layers of gesso

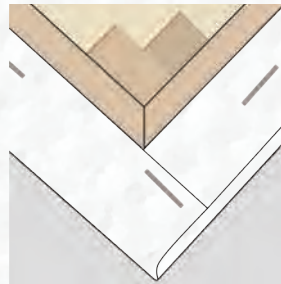

corner tightening wedges to increase tautness when and if needed

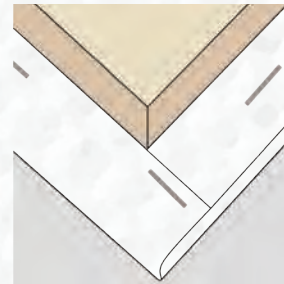

all the canvases are back-stapled, with a pine wood frame

Barcode	Article Number	Size
8 888313 107928	CV C0606-150	6"x6"
8 888313 107959	CV C0808-150	8"x8"
8 888313 107935	CV C1212-150	12"x12"
8 888313 101582	CV C1216-150	12"x16"
8 888313 101490	CV C1418-150	14"x18"
8 888313 101506	CV C1620-150	16"x20"
8 888313 101513	CV C1824-150	18"x24"
8 888313 101520	CV C2020-150	20"x20"
8 888313 101537	CV C2024-150	20"x24"
8 888313 107942	CV C2424-150	24"x24"
8 888313 089996	CV C2430-150	24"x30"
8 888313 101544	CV C2436-150	24"x36"
8 888313 101551	CV C3040-150	30"x40"
8 888313 101568	CV C3636-150	36"x36"
8 888313 103500	CV C3648-150	36"x48"
8 888313 101575	CV C4860-150	48"x60"

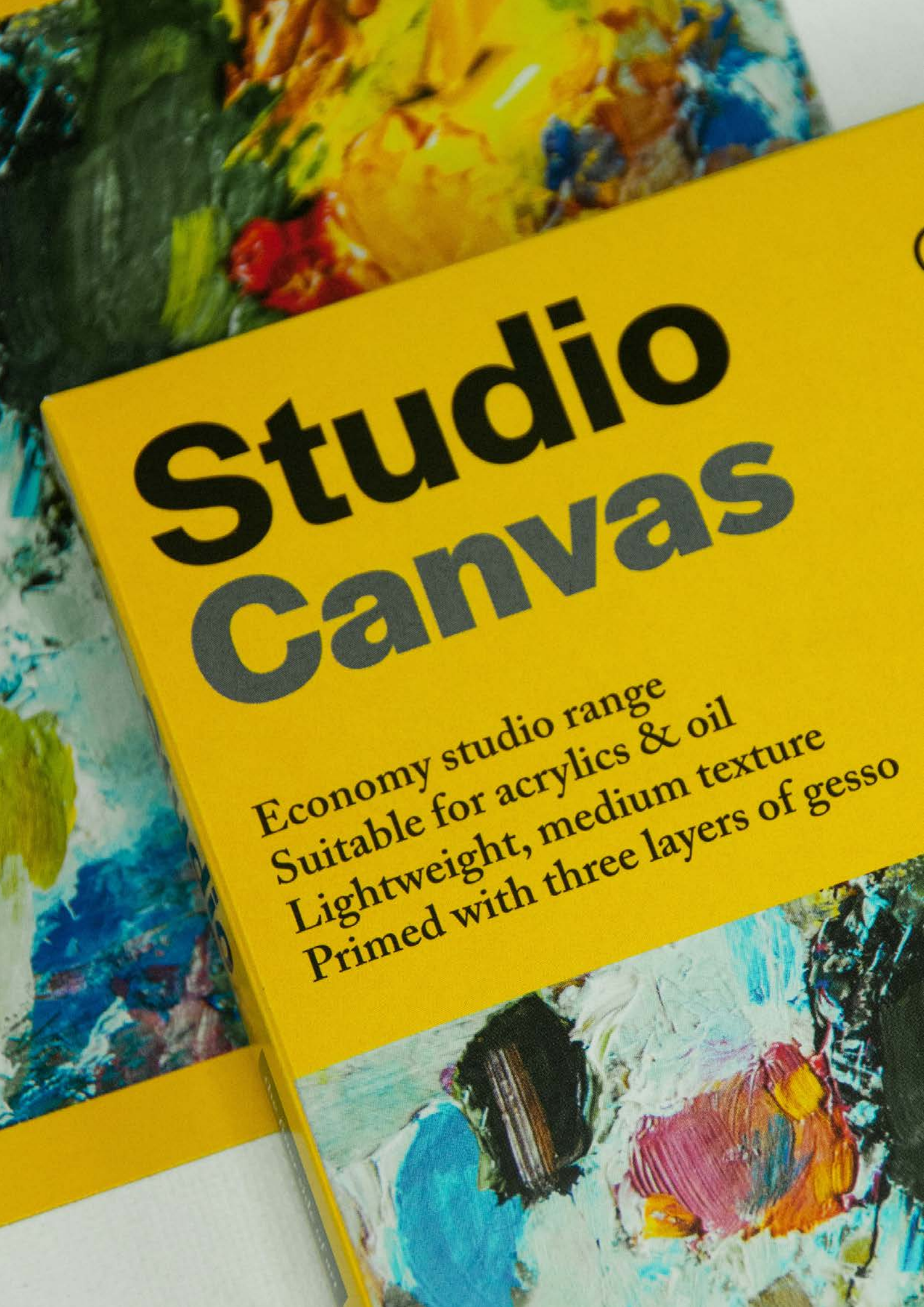

Studio Canvas

Economy studio range
Suitable for acrylics & oil
Lightweight, medium texture
Primed with three layers of gesso



KCK Studio Canvas Classic 3/4 Inch (100% Cotton)

KCK Studio Economy Range Canvas offers a 280g/m² medium weight cotton fabric that is triple primed with a neutral white gesso, stretched over a sturdy pine wood frame and secured with back staples. Available in the classic 3/4 inch and in different dimensions of canvases which offers versatility to usage. Suitable for oil and acrylic paint of painting.



1.5 Inch



280 g/m²



medium texture grain, primed with three layers of gesso



corner tightening wedges to increase tautness when and if needed

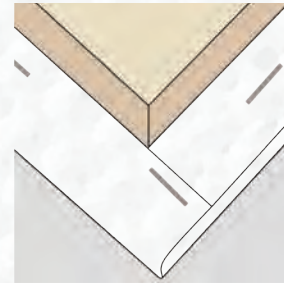

all the canvases are back-stapled, with a pine wood frame

Barcode	Article Number	Size
8 888313 112465	CV 28C0404-075	4"x4"
8 888313 112472	CV 28C0507-075	5"x7"
8 888313 112489	CV 28C0606-075	6"x6"
8 888313 112496	CV 28C0709-075	7"x 9"
8 888313 112502	CV 28C0808-075	8"x8"
8 888313 112519	CV 28C0812-075	8"x12"
8 888313 112526	CV 28C1114-075	11"x14"
8 888313 112533	CV 28C1212-075	12"x12"
8 888313 112540	CV 28C1216-075	12"x16"
8 888313 112557	CV 28C1418-075	14"x18"
8 888313 112564	CV 28C1620-075	16"x20"
8 888313 112571	CV 28C1818-075	18"x18"
8 888313 112588	CV 28C1824-075	18"x24"

Artist canvas panels

280g/m²

Acrylic triple
Suitable

100% Pure Cotton Canvas

8x



Canvas Panel (100% Pure Cotton)



Canvas Panel (100% Pure Cotton)

KCK Canvas Panel offers a 280g/m² medium weight cotton fabric that is triple primed with a neutral white gesso, stretched over a cardboard backing. The thinness of the panel is suitable for compact and portable storage. Available in different dimensions of canvas panels which offers versatility to usage. Suitable for oil and acrylic paint.

Order Code	Article Number	Size
	CV PC0507	5"x7"
	CV PC0709	7"x9"
	CV PC0808	8"x8"
	CV PC0810	8"x10"
	CV PC0812	8"x12"
	CV PC1212	12"x12"
	CV PC1216	12"x16"
	CV PC1824	18"x24"
	CV PC2436	24"x36"

staplefree



3 mm 280 g/m²



panel thickness
3mm
width

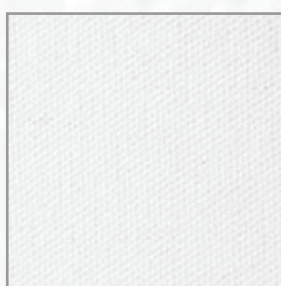

medium texture grain,
primed with three layers of gesso



cardboard backing

KCK
CASA-ART

5 in 1
Value Pack

— 100% Pure Cotton Canvas —

280g / m²
Acrylic triple gesso primed
Suitable for oil and acrylic
Medium texture
Acid-free

Artist
canvas panel

CE mark

KCK Canvas Panel 5-in-1 Pack (100% Pure Cotton)



• 5-in-1 Pack

staplefree

Canvas Panels (100% Pure Cotton)

KCK Canvas Panel 5-in-1 Pack offers a 280g/m² medium weight cotton fabric that is triple primed with a neutral white gesso, stretched over a cardboard backing. The economical, portable pack is suitable for on-the-go painters, beginners and at home painting. Available in different dimensions of canvas panels which offers versatility to usage. Suitable for oil and acrylic paint.

Order Code	Article Number	Size
	CV PC0404-5	4"x4"
	CV PC0507-5	5"x7"
	CV PC0606-5	6"x6"
	CV PC0709-5	7"x9"
	CV PC0808-5	8"x8"
	CV PC0912-5	9"x12"
	CV PC1010-5	10"x10"
	CV PC1212-5	12"x12"
	CV PC1216-5	12"x16"



3 mm



280 g/m²



panel thickness
3mm
width

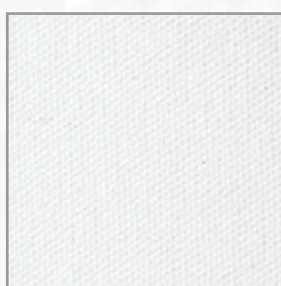

medium
texture
grain,
primed
with three
layers of
gesso



cardboard
backing

Canvas Pad

Economy studio range
Suitable for acrylics & oil
Lightweight, medium texture
Primed with three layers of gesso

A5

148mm x 210mm

280g/m²

10 sheets

Acid-Free

100% Cotton







KCK Canvas Pad - 280g/m²



KCK Canvas Pad - 280g/m²

KCK Canvas Pad offers 10 canvas sheets that are 100% cotton and acid-free. Each canvas sheet is triple primed with a neutral white gesso. Lightweight, easy to store and carry, these canvas sheets can be easily removed from its cardboard backing for easy framing. The economical, portable pack is suitable for on-the-go painters, beginners and at home painting. Sheets can easily be taped onto a wooden panel and then placed onto a easel for an easy painting form. Suitable for oil and acrylic paint.

Order Code	Article Number	Size
	CV CP28A5-10	A5
	CV CP28A4-10	A4
	CV CP281212-10	12"x12"
	CV CP28A3-10	A3

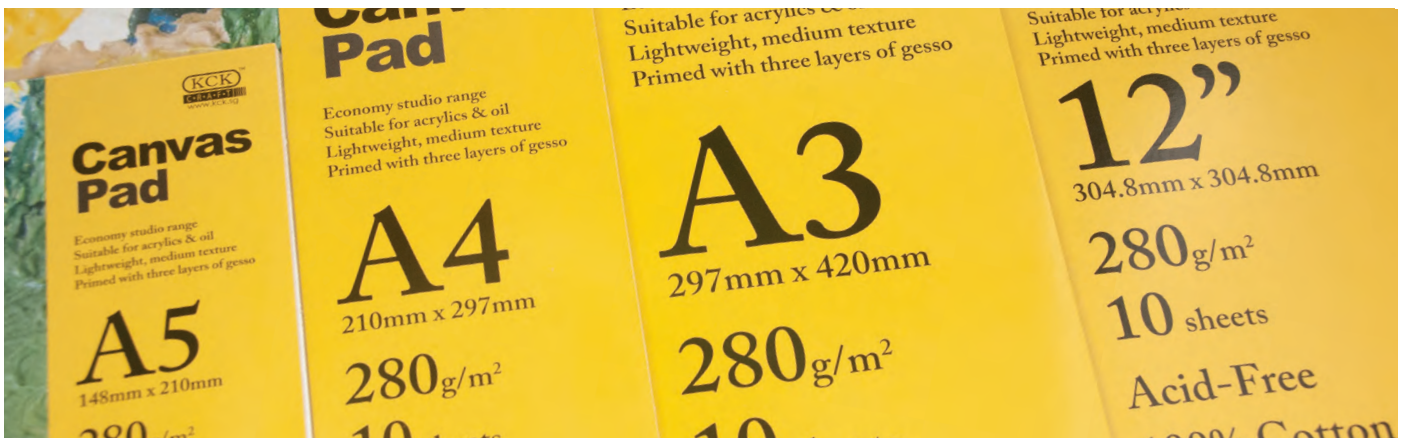





KCK Classic Edge Canvas Double Clip

Made up of stainless steel, this high-quality canvas clip temporarily binds two canvases together. This Classic Edge Canvas Double Clip provides convenience and easy transport of two canvases of various sizes. This clip carrier separates a dry and wet painting and prevents the canvases surfaces from getting stained.

Order Code

PI 2160



- Secure 2 Canvases**

- Transport 2 canvases of various sizes easily. With two Canvas Double Clip, bind two sides of each canvas to secure both of the canvases together

- Protects Canvas**

- Protects two canvases surface from getting stained. Protect both dry and wet paintings.

- Measurement Size**

- 6x3x3cm

- Material**

- Stainless Steel





Front



Back



KCK Portfolio Art Bag

This Portfolio Bag is perfect for Art Students and on-the-go artists that carry artworks and art materials daily. This bag comes in two partitions. The zipped section is suitable to keep drawing and painting mediums like paints, palettes, pencils, pastels. The transparency of the bag helps to reach for the items more efficiently. The buckled section is great for storing paper pads, clipboards and canvases, separating the wet from the dry medium.

Size	Order Code	Barcode
A3	PFA3	
A2	PFA2	
A1	PFA1	



• **Comes in 3 Sizes**

• This Portfolio Bag comes in three sizes; A3, A2 and A1. All the bags comes with a hand carry strap while the A2 and A1 has an additional shoulder strap.

• **Buckle Section**

• The buckle section of the bag secures flat materials like wooden clipboards, pads and canvases.

• **Zipped Section**

• Materials such as paint, palettes, brushes, and, canvases are able to be stored in this zipped section. The zipped and buckle section separates the dry mediums from the wet mediums.



Separate pads and canvases from wet mediums



Hand & Shoulder Straps



Buckle to secure pads and boards





KCK Pine Wood Display Easel

Height: 20/30/40/50cm

Code: EA 101P

- Pine Wood (Natural Beige)
- Fixed Mast and Holder
- Rope Fixture
- Double Mast Feature

KCK Pine Wood Display Easel suitable for holding lightweight canvases, photographs, signs and more. Lightweight and folds easily for storage. The perfect display easel to decorate your home, embellish your work desk or mini art as a gift. Even Craft Activities for kids. Suitable for small canvases or canvas panels.



Height: 20cm
Code: EA 101P-20



Height: 30cm
Code: EA 101P-30



Height: 40cm
Code: EA 101P-40



Height: 50cm
Code: EA 101P-50







KCK Small Round Corner Box Easel

Dimensions: 24cm(W) x 55/97cm(H)

Code: EA 502B



- **Tabletop Easel**
- **Beech Wood (Natural Beech)**
- **Adjustable Mast**
- **Metal Hinges**
- **Adjustable Top Holder**
- **Wing Screw Fixtures**
- **Easily Assembled, Stable & Sturdy**



KCK Tabletop Box Easels are suitable for outdoor painting and they are easy to store and transport. Readily available for indoor or on-the-go painters and even beginners. Adjustable Canvas Holder for larger canvases. Extensive Storage Compartment with removable dividers for all your painting mediums. Made up of sturdy materials. The easel comes with a leather carrying handle.

KCK Tabletop Easel



Leather Carrying Handle



Locking Storage Drawer



KCK Table Box Easel - Beech

Dimensions: 69cm(W) x 42/70cm(H)
Code: EA 503 B

- **Tabletop Easel**
- **Beech Wood (Natural Beige)**
- **Adjustable Double Mast**
- **Adjustable Top Holder**
- **Wing Screw Fixture**
- **Worktray and Rubber Feet Feature**



8 888313 106389



Controls the angle of the board



Folds Flat for Storage

KCK Table Easel - Beech

Dimensions: 27.5cm(W) x 75/97cm(H)
Code: EA 501B

- **Tabletop Easel**
- **Beech Wood (Natural Beige)**
- **Adjustable Mast**
- **Adjustable Top holder**
- **Wing Screw Fixture**
- **Middle Holder Feature**



8 888313 106334

KCK Tabletop Box Easels are suitable for outdoor painting and they are easy to store and transport. Readily available for indoor or on-the-go painters and even beginners. Adjustable Canvas Holder for larger canvases. Extensive Storage Compartment with removable dividers for all your painting mediums. Made up of sturdy materials for added stability to protect table surfaces.

KCK A/H Frame Easel



Folds Flat for Storage



KCK French Rear Support Easel - Beech

Dimensions: 52cm(W) x 140cm(H)

Code: EA 201B

- **A-frame Easel**
- **56cm x 146/230cm**
- **Beech Wood (Natural Beige)**
- **Adjustable Double Mast**
- **Adjustable top and bottom holder**
- **Wing Screw Fixture**
- **Bracket Knob and Worktray Feature**



KCK Studio Easel - Beech

Height: 60cm(W) x 190/250cm(H)

Code: EA 801B

- **H-Frame Easels**
- **Beech Wood (Natural Beige)**
- **Adjustable Double Mast**
- **Adjustable Top and Bottom Holder**
- **Wing Screw Fixture**
- **Bracket Knob Fixture**



KCK A/H Frame Easels are suitable for Home and Studio Painting. Able to prop up canvases, panels, and other media. Its adjustable Canvas Holder can hold large Canvases/ Panels. Built-In Ledge/Space Compartments for placing brushes and mediums. Made up of sturdy materials for added stability when painting.

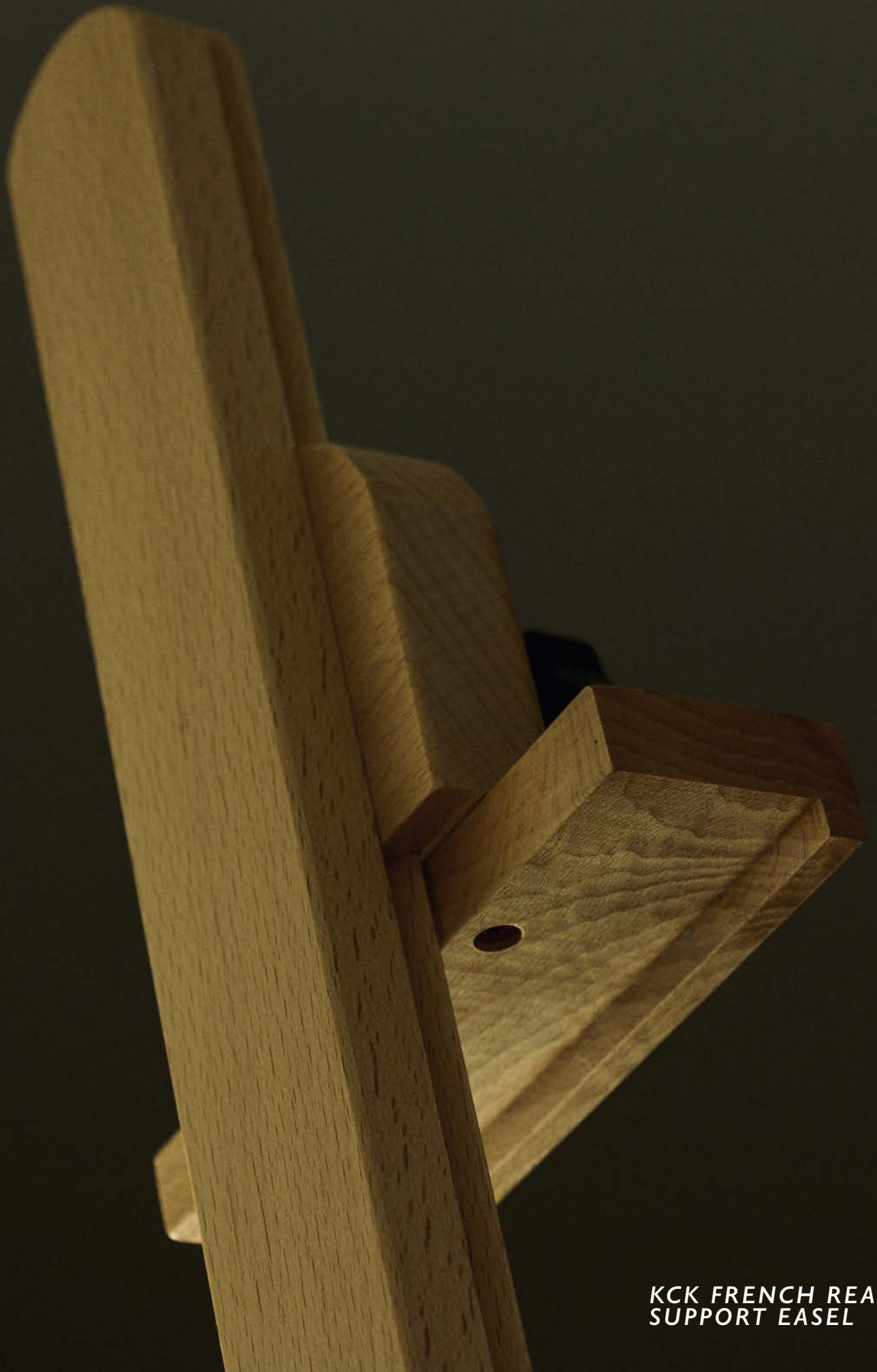

**KCK FRENCH REAR
SUPPORT EASEL**



BUILT-IN LEDGE FOR
PAINTS AND MEDIUMS



A-FRAME EASELS



PINE WOOD



BEECH WOOD



BRASS METAL HINGES



BRACKET KNOB FEATURE





KCK French Rear Support Easel - Black

Dimensions: 60cm(W) x 165cm(H)

Code: EA 203P-BK



- **A-frame Easel**
- **Pine Wood (Black)**
- **Adjustable Mast**
- **Metal Hinges**
- **Adjustable Top & Bottom Holders**
- **Bracket Knob and Wing Screw Fixtures**
- **Worktray and Rubber Feet feature**

KCK French Rear Support Easels are made for practical studio and display usage. Its Steady Structure & Great Finish makes it a great all-rounder for artists of all skill levels. Folds easily for Compact Storage with a Built-In Ledge for placing brushes and materials. Suitable for both indoor and outdoor painting. Accommodate canvases, boards, and panels.





KCK French Rear Support Easel - Beech

Dimensions: 60cm(W) x 165cm(H)

Code: EA 204B



- **A-frame Easel**
- **Beech Wood (Natural Beige)**
- **Adjustable Mast**
- **Metal Hinges**
- **Adjustable Top & Bottom Holders**
- **Bracket knob & Wing Screw Fixtures**
- **Worktray and Rubber Feet Feature**

KCK French Rear Support Easels are made for practical studio and display usage. Its Steady Structure & Great Finish makes it a great all-rounder for artists of all skill levels. Folds easily for Compact Storage with a Built-In Ledge for placing brushes and materials. Suitable for both indoor and outdoor painting. Accommodate canvases, boards, and panels.

KCK Big Master Easel



Castor Wheels to maneuver the Easel easily



Convertible Easel for use with all Painting Media



KCK Multi Function Easel - Beech

Dimensions: 56 cm(W) x 144/200cm(H)
Code: EA 901B

- Big Master Easel
- Natural Beech Wood
- Adjustable Double Mast
- Adjustable top and bottom holder
- Wing Screw Fixture
- Bracket Knob Feature
- Worktray, Wheels, Middle holder



Multiple Built-In Ledge to accommodate brushes and paints



KCK Big Master Easel - Beech

Dimensions: 54cm(W) x 146/230cm(H)
Code: EA 902B

- Big Master Easel
- Natural Beech Wood
- Adjustable Double Mast
- Adjustable top and bottom holder
- Wing Screw Fixture
- Bracket Knob Feature
- Worktray, Wheels, Middle holder and Rubber Feet Feature



KCK Big Master Easels are suitable for small to large paintings. It tilts back to any angle that suits your medium and painting style. Its functional design and incredible versatility allows to convert the easel easily into a table to allow watercolours or poured paintings. Built-in ledge allows placement of brushes and mediums. The sturdy base has heavy duty castor wheels to easily maneuver the easel.



Adjustable Legs



Easy to carry form



KCK Triangle Easel - Pine

Dimensions: 55cm(W) x 140/185cm(H)

Code: EA 401P

- Tripod Easel
- 56cm x 140/185cm
- Pine Wood (Natural Beige)
- Adjustable Double Mast
- Adjustable top and bottom holder
- Wing Screw Fixture
- Bracket Knob and Worktray feature



Leather Handle



KCK Master Tripod Easel - Beige

Height: 55cm(W) x 120/167cm(H)

Code: EA 903B

- Tripod Easel
- Natural Beech Wood
- Adjustable Mast
- Adjustable Top and Bottom Holder
- Worktray & Rubberfeet feature



Floor-Stanning & Tabletop Configurations



Telescopic Legs

KCK Aluminium Easel

Height: 96cm(W) x 87cm(D) x 140/192cm(H)

Code: EA AL150

- Tripod Easel
- Black Aluminium
- Adjustable Mast
- Adjustable Top and Bottom Holder
- Rubberfeet feature



KCK Tripod Easels are slim, lightweight and fully collapsible. Suitable to transport for the on-the-go painters-and just as easy to store in your home or studio. Made from sturdy materials giving a stable tripod base to the easel

KCK Plein Air Easel



Adjustable Legs for Different Terrains



Compact Stow Away Legs Design



Easily Assembled

KCK French Box Easel - Brown

Dimensions: 38cm(W) x 110/200cm(H)

Code: EA 602 BR

- Plein Air Easel
- Brown Beech Wood
- Adjustable mast
- Adjustable top and bottom holder
- Wing Screw Fixture
- Worktray and Rubber Feet Feature



8 888313 106365

KCK French Box Easel - Beech

Dimensions: 38cm(W) x 110/120cm(H)

Code: EA 601 B

- Plein Air Easel
- Natural Beech Wood
- Adjustable Mast
- Adjustable Top and Bottom Holder
- Wing Screw Fixture
- Worktray and Rubber Feet Feature



8 888313 106365



KCK French Box Easels are suitable for outdoor painting and they are easy to store and transport for on-the-go painters. Adjustable Canvas Holder for large canvases. Extensive Storage Compartment with removable dividers -Space for all your painting mediums with a Built-In Ledge for placing brushes and mediums. Made up of sturdy materials. The easels comes with a leather carrying handle.



Book 2 - Brushes and Tools



PLEASE RECYCLE

www.kck.sg



DRAWING & SKETCHES



Introduction

Choong Marketing was established in 1998 by Mr K C Kang. We are an importer/exporter and distributor of stationery and art-based materials in Singapore. Since then, it is our company mission to supply our customers with quality products. Over the years we have grown at a steady pace; increasing product range, brand representation and channels to customers. As we continue to grow, we will continue to strengthen our position by working with partners with shared values and not forgetting our mission of providing ordinary products with extraordinary quality.

The Brands

If people are the company's right hand, the brands and partners would surely be its left hand. We value every brand we represent and it's our preference to work with brands that complement each other so that we would be able to grow in strength together. The following are brands that we represent exclusively:

•AMOS •CARIOCA •DREAM
•KANGARO •KCK QUALITY •KCK CRAFT
•KEBA KUM •MARVY UCHIDA •MONTANA CANS
•PLAY •SADIPAL •SIO-2 •KUSAKABE •SENNELIER
•PAPA CLAY •ALPHA COLOURS •YOUNG ARTIST

Contents

Pg 4 - 5	KCK Drawing Pencils
Pg 6 - 9	KCK Colour Pencils
Pg 10 - 15	KCK Paper Stumps, Wooden Panel, Drawing Panel & Clipboard
Pg 16 - 17	KCK Wooden Human Figure & Wooden Hand
Pg 18 - 19	KCK Mannequin
Pg 20 - 23	Marvy Uchida Drawing Pen & Pen Sets
Pg 24 - 25	Marvy Uchida Le Pen
Pg 26 - 27	Marvy Uchida Multi Marker
Pg 28 - 31	Marvy Uchida Artist Brush & Brush Sets
Pg 32 - 33	Marvy Uchida Decocolor Marker
Pg 34 - 35	Marvy Uchida Industrial Paint Marker
Pg 36 - 37	Marvy Uchida Fabric, Calligraphy & Chalk Markers
Pg 38 - 41	Alpha Design Marker, Sets & Nibs
Pg 42- 43	Marvy Uchida Tracing Board



Order Code Barcode

PE 222-12

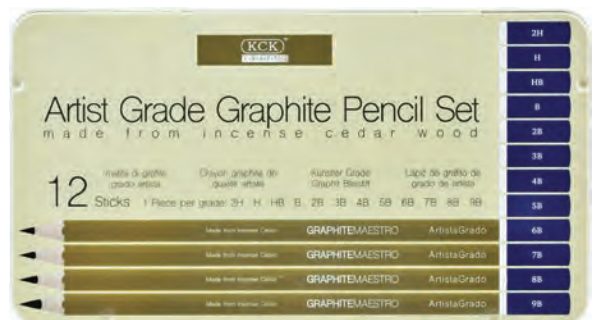

KCK Artist Grade Graphite Pencil Set

The KCK Artist Graphite Pencils are the complete range of artist-quality graphite pencils with a lead grade from the hardest 2H to the softest 9B. The pencils are of hexagonal shape with a centred premium quality graphite lead varying from 2.0 mm to 3.5 mm, making it convenient and easy to hold. Suitable for drawing, sketching as well as technical layouts and design work. The pencils are made from the incense cedar wood - an ideal wood for premium-quality artist pencils.



wood & lead treatment ensure strength and break-resistance

Swatches are closely represented in the figure

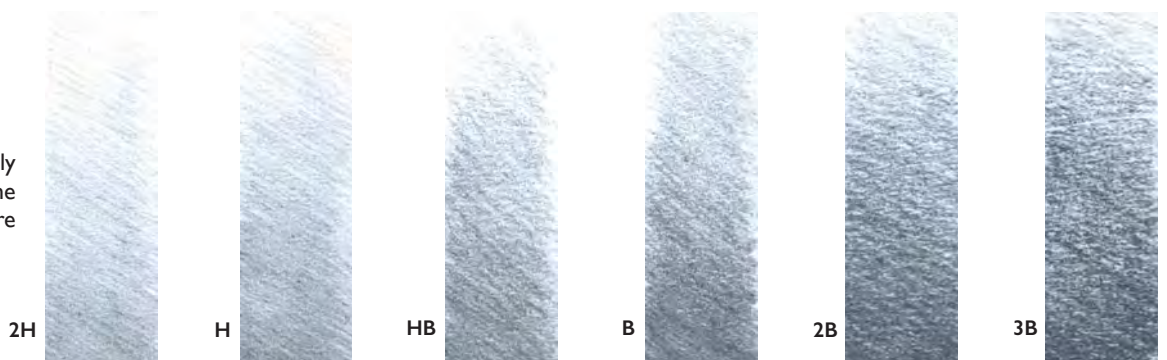



**KCK Artist Grade Graphite Pencil
- Single Grade Box (12 Pencils)**

The KCK Artist Grade Graphite Pencils are suitable on most types of paper such as watercolour, drawing, colour paper, art cards, constructed or tracing paper. It's suitable over harder and rougher surfaces such as wooden panels and canvases. The pencils show thick and opaqueness even over medium like soft pastels, oil pastels, paintings after the mediums have been set to dry. This pencil is able to be sharpened with a pencil sharpener or a razor blade to let the artists draw a sharp, precise line or a wide broad stroke giving KCK's Artist Grade pencils as one of the most versatile and effective drawing tool.

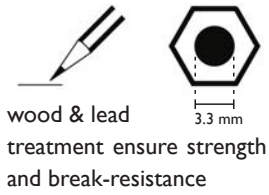

wood & lead treatment ensure strength and break-resistance



made with artist quality graphite

developed with a special coat for a better break-resistance



made from premium incense cedar wood



Order Code	Colour	Barcode
PE 222-12-2H	2H	
PE 222-12-H	H	
PE 222-12-HB	HB	
PE 222-12-B	B	
PE 222-12-2B	2B	
PE 222-12-3B	3B	

Order Code	Colour	Barcode
PE 222-12-4B	4B	
PE 222-12-5B	5B	
PE 222-12-6B	6B	
PE 222-12-7B	7B	
PE 222-12-8B	8B	
PE 222-12-9B	9B	

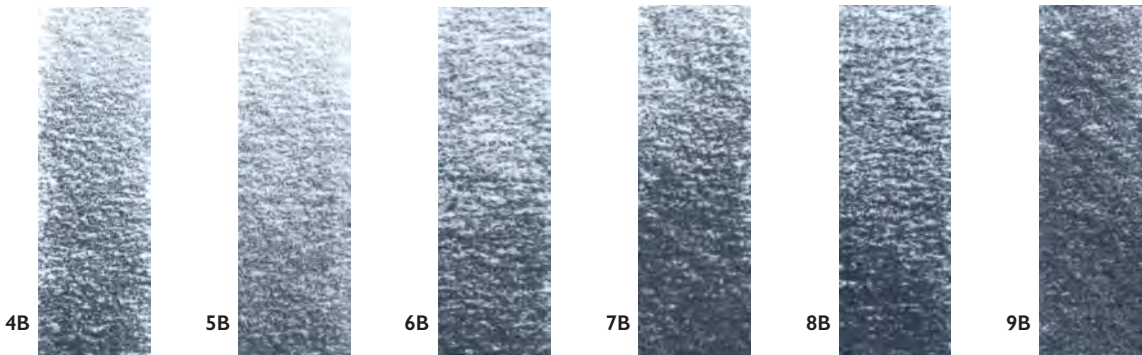

Swatches are done on:

**KCK Studio Collection
135gsm Cold Pressed
Drawing Paper
(PP DPI35A4-25)**

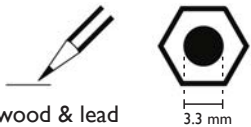

wood & lead treatment ensure strength and break-resistance



Order Code	Colour	Barcode
CP-1012	12	
CP-1024	24	
CP-1036	36	

KCK Blend Maestro Classic Colour Pencil

Available in sets of 12, 24, and 36, these classic colour pencils are produced with an artist-quality pigment. These colour pencils are smooth, vibrant, and are easy to blend. KCK Blend Maestro Water Soluble Colour Pencils are designed with a classic hexagon barrel; therefore, it maintains the best possible grip for the artist while having an advantage of being non-roll on surfaces. Enhanced 3.3mm dia core gives you more coverage while working. Non-toxic. Conforms to EN71-3.



Snow White



Light Beige



Canola Yellow



Lemon Yellow



Golden Yellow



Tangerine Orange



Salamander Orange



Scarlet Red



Crimson Red



Orchid Pink



Raspberry Dark



Lilac



Deep Purple



Indigo Purple



Vivid Blue



Cobalt Blue



Deep Blue



Azure Blue



Aqua Blue



Sky Blue



Emerald Green



Yellow Green



Phthalo Green



Forest Green



Hunter Green



Ochre Deep



Red Copper



Caramel Brown



Chocolate Brown



Umber Brown



Ash Grey



Fossil Grey



Iron Grey



Black



Metallic Gold



Metallic Silver

Swatches are closely represented in the figure

Swatches are done on:

KCK Studio Collection, 135gsm Cold Pressed Drawing Paper (PP DPI35A4-25)

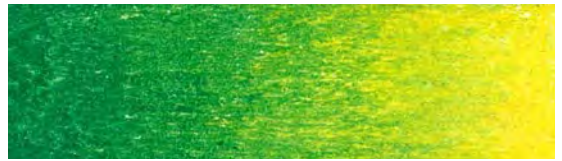

Analogous Colour Gradient

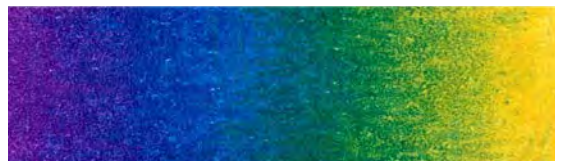

Split Complimentary Colours

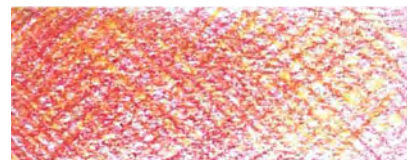

Cross-Hatching

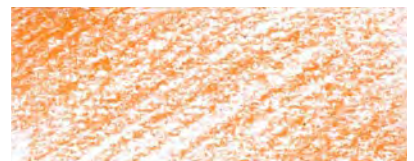

Hatching

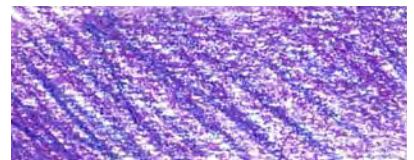

Back & Forth

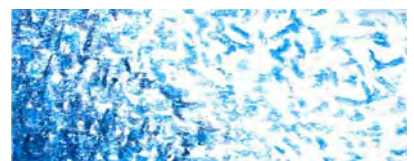

Stippling

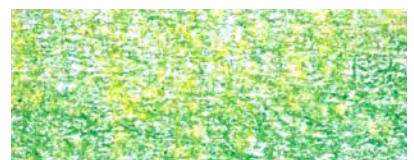

Scumbling

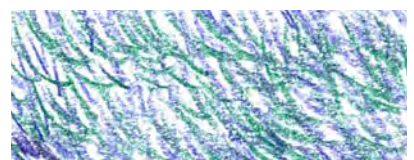

Multi-Directional Strokes



Artworks are done on:
Dream Artist Softcover Bound A5L Journal (PP SJ160A5L-64)



+ Brush



Order Code	Colour	Barcode
CP-2012	12	
CP-2024	24	
CP-2036	36	

KCK Aqua Maestro Water Soluble Colour Pencil

Available in sets of 12, 24, and 36, these watercolour pencils are produced with an artist-quality pigment. These watercolour pencils are smooth, vibrant, and easy to be activated with a little bit of water. KCK Aqua Maestro Water Soluble Colour Pencils are designed with a classic hexagon barrel; therefore, it maintains the best possible grip for the artist while having an advantage of being non-roll on surfaces. Enhanced 3.3mm dia core gives you more coverage while working. Non-toxic. Conforms to EN71-3.

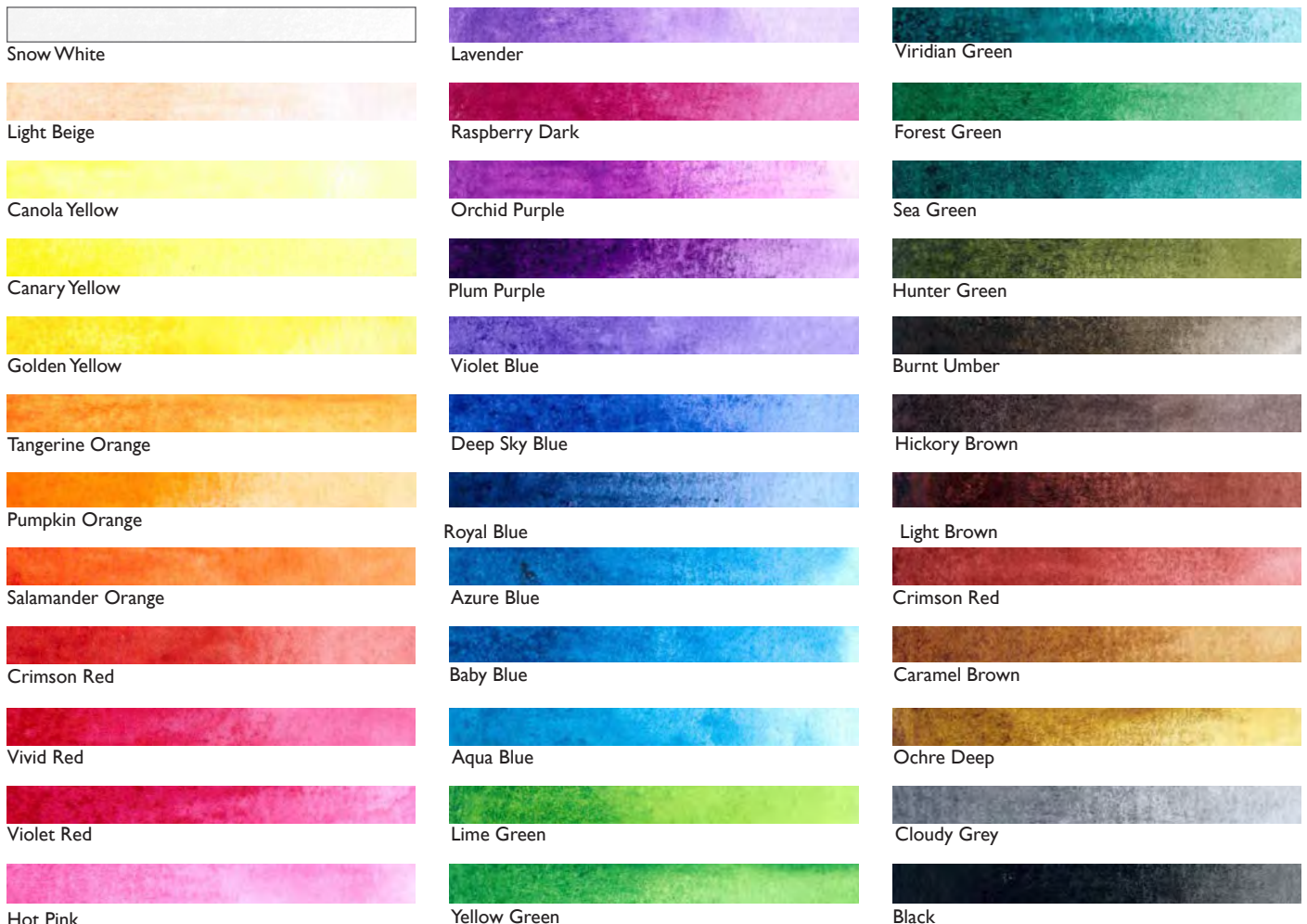

Swatches are closely represented in the figure

Swatches are done on: KCK Studio Collection, 135gsm Cold Pressed Drawing Paper (PP DP135A4-25)



Wet Pencil on Wet Paper



Activated



Layered & Activated

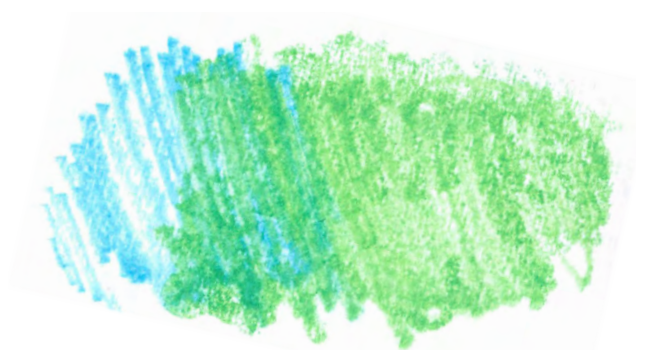

Dry Pencil on Wet Paper



Dry Pencil Layered & Activated



Watercolour Pencils as Portable Paints using Brush



- soft
- smooth
- vibrant



wood & lead treatment ensure strength and break-resistance

Artworks are done on:
Dream A4 Watercolour Paper Series I

KCK Paper Stumps

KCK Paper Stumps is an excellent stool for blending and smoothing soft pastels, colour pencils, graphite, and charcoal. This paper stumps come in a set of 3 sizes and is suitable for creating shadows and a hazy effect on a drawing /sketch. This paper stumps are also able to be sharpened by a regular sharpener or a pen knife when the tip is blunt. Available in a set of Size 5,8 and 11.



Order Code	Size	Barcode
HC BL 1185	5	

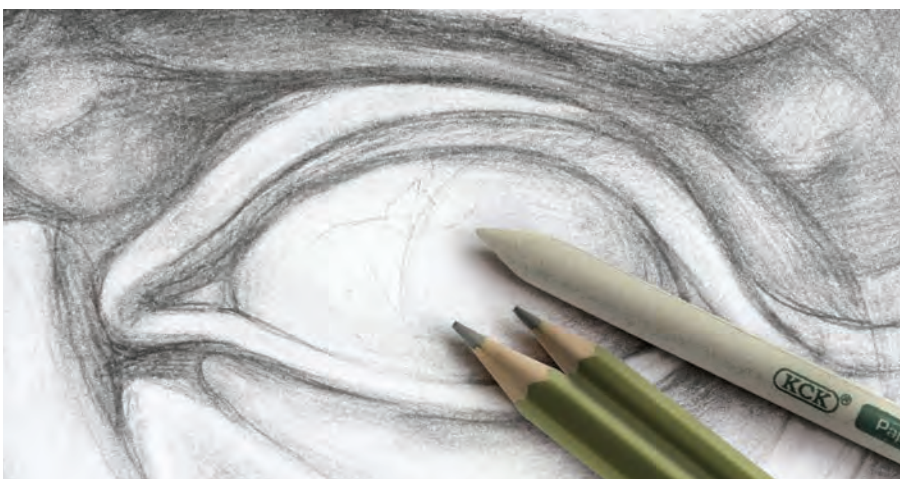

KCK Wooden Drawing Clipboard - Beech Wood



KCK Wooden Drawing Clipboard is made up of beech wood, this beech panel gives sturdy and additional support when drawing and sketching. This clipboard features a handle for on-the-go artists suitable for outdoor/ indoor drawing. This clipboard has a metal binder that is well-built and strong that binds a set of drawing papers together. On top of the metal binder, the elastic band gives additional support that keeps the drawing paper and stationaries secure. On top of that, this clipboard has a smooth surface and edges with rounded corners. Available in A3 and A2 sizes.

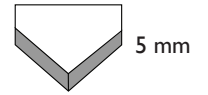

A2 Size

A3 Size



Order Code	Size	Barcode
WD SKB-A3	A3	 8 888313 106693 4
WD SKB-A2	A2	 8 888313 106686 4





KCK Beech Wood Panel - 3/4 Inch Cradled

KCK Beech Wood Panel is made up of beech wood, this beech panel gives sturdy and additional support when drawing and sketching. Suitable for on the go, outdoor, and indoor drawing/painting. Using masking tape to tape oil/acrylic paper on this wood panel and this wooden panel can easily be placed on an easel. Loose drawing paper can have additional support by using a binder to compile the drawing papers onto the wood panel. Lastly, this wooden panel is the perfect surface for mixed media painting as this wood panel has a smooth finish. Available in a wide range of sizes, in both Classic and Deep Edge.



beech wood

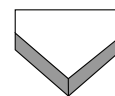

3/4 inch



Order Code	Size	Barcode
WD P0606-075	6" x 6"	
WD P0808-075	8" x 8"	
WD P0810-075	8" x 10"	
WD P0912-075	9" x 12"	
WD P1114-075	11" x 14"	
WD P1212-075	12" x 12"	
WD P1216-075	12" x 16"	
WD P1620-075	16" x 20"	
WD P1824-075	18" x 24"	





KCK Beech Wood Panel - 1.5 Inch Cradled

KCK Beech Wood Panel is made up of beech wood, this beech panel gives sturdy and additional support when drawing and sketching. Suitable for on the go, outdoor, and indoor drawing/ painting. Using masking tape to tape oil/acrylic paper on this wood panel and this wooden panel can easily be placed on an easel. Loose drawing paper can have additional support by using a binder to compile the drawing papers onto the wood panel. Lastly, this wooden panel is the perfect surface for mixed media painting as this wood panel has a smooth finish. Available in a wide range of sizes, in both Classic and Deep Edge .

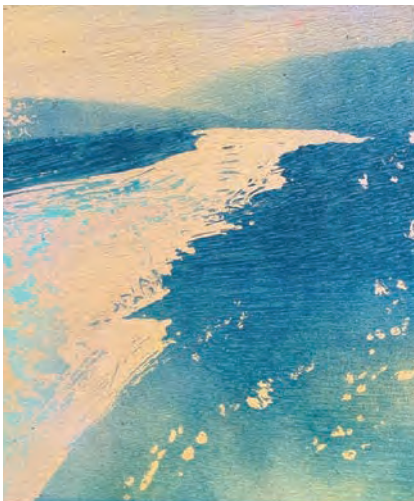
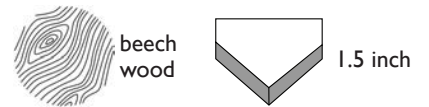

Order Code	Size	Barcode
WD P0606-150	6" x 6"	
WD P0808-150	8" x 8"	
WD P0810-150	8" x 10"	
WD P0912-150	9" x 12"	
WD P1114-150	11" x 14"	
WD P1212-150	12" x 12"	
WD P1216-150	12" x 16"	
WD P1620-150	16" x 20"	
WD P1824-150	18" x 24"	



KCK Wooden Board - Beech Wood

KCK Drawing Panel is made up of beech wood, this beech panel gives sturdy and additional support when drawing and sketching. Suitable for on the go, outdoor, and indoor drawing/ painting. Using masking tape to tape oil/acrylic paper on this wood panel and this wooden panel can easily be placed on an easel. Loose drawing paper can have additional support by using a binder to compile the drawing papers onto the wood panel. Lastly, this wooden panel is the perfect surface for mixed media painting as this wood panel has a smooth finish. Available in A4, A3 and A2 sizes, this wooden panel has a thickness of 5mm.





A2 Size

A3 Size

A4 Size



Order Code	Size	Barcode
WD 10A4-5	A4	
WD 10A3-5	A3	
WD 10A2-5	A2	



KCK Drawing Board - Beech Wood

KCK Drawing Board is made up of beech wood, this beech panel gives sturdy and additional support when drawing and sketching. Suitable for on the go, outdoor, and indoor drawing/ painting. Using masking tape to tape oil/acrylic paper on this wood panel and this wooden panel can easily be placed on an easel. Loose drawing paper can have additional support by using a binder to compile the drawing papers onto the wood panel. Lastly, this wooden panel is the perfect surface for mixed media painting as this wood panel has a smooth finish. Available in A3, A2 and A1 size.



A1 Size

A2 Size

A3 Size

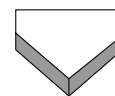

Order Code	Size	Barcode
WD DB-A3	A3	 8 888313 106679
WD DB-A2	A2	 8 888313 106662
WD DB-A1	A1	 8 888313 106655



KCK Wooden Human Figure

KCK Wooden Human Figure is made up of beech wood that is durable and smooth. Built with joints that are flexible and accurately proportioned to a human body, this wooden human figure follows many human poses. This is suitable for beginners and art students studying the structure of the human body by practicing proportions, form and shading. With 3 types of figures to choose from; a general mannequin, female and male mannequin, these figures are lightweight and easy to carry. Suitable for on-the-go painting/ sketching and figure drawing lessons. Available individually and comes in sets of female and male.



Wooden Mannequin
5.5"



Wooden Mannequin
Male 8"/12"



Wooden Mannequin
Female 8"/12"



Order Code	Size	Barcode
WD 055	Mannequin 5.5"	
WD MF080	Mannequin Female 8"	
WD MM080	Mannequin Male 8"	
WD MF120	Mannequin Female 12"	
WD MM120	Mannequin Male 12"	

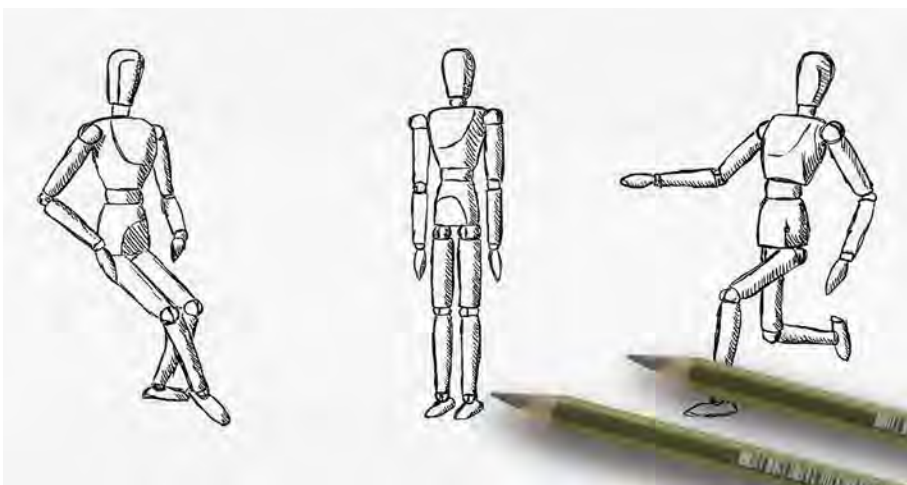

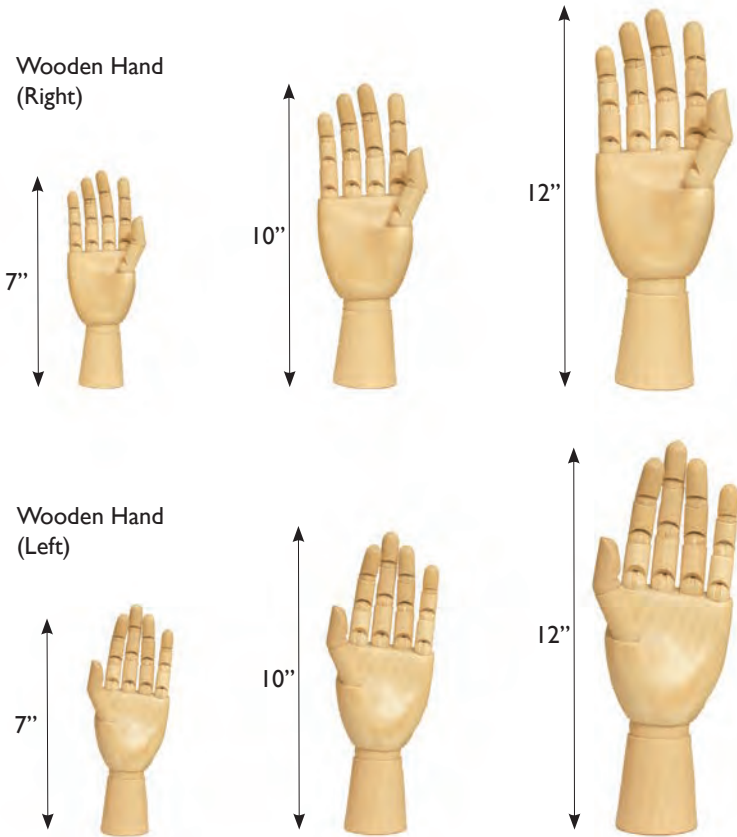

KCK Wooden Hand

KCK Wooden Hand is made up of beech wood that is durable and smooth. Built with joints that are flexible and accurately proportioned to a human hand, this wooden hand flexibly imitates hand gestures and poses. This is suitable for beginners and art students studying the structure of the human hand in-depth by practising proportions, form and shading. Suitable for on-the-go painting/sketching and figure drawing lessons. This Left & Right Wooden Hand are available individually in 3 sizes; 7, 10, and 12 inches. KCK Wooden Hand is also available in sets of left and right hand.



Order Code	Size	Barcode
WD HL070	Left 7"	
WD HR070	Right 7"	
WD HL100	Left 10"	
WD HR100	Right 10"	
WD HL120	Left 12"	
WD HR120	Right 12"	



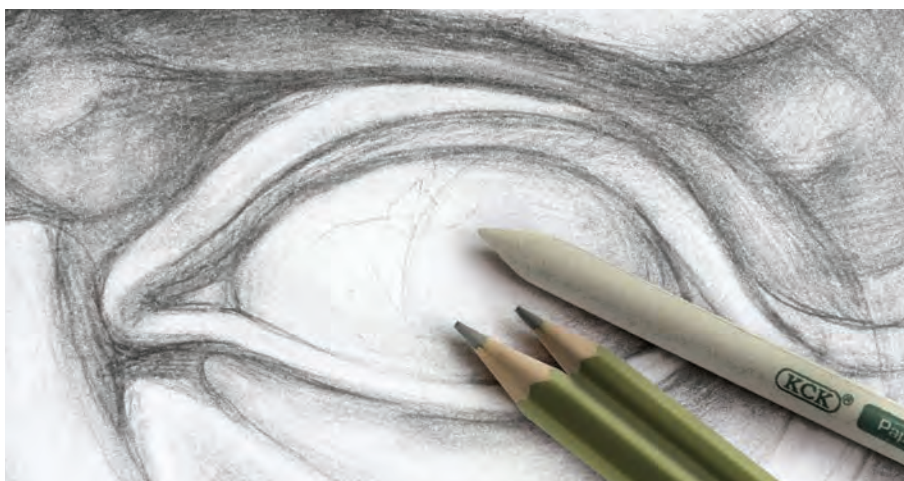

KCK David Cast Model

KCK David Cast Model are scaled down proportionately to inherit the Classic David Masterpiece. Built with plaster. This Master Cast Model is suitable for beginners and art students studying the structure of the human face in-depth by practising face proportions in different angles, form and shading. Suitable for on-the-go painting/sketching and figure drawing lessons. Not only is this David Cast Model great as a tool for sketching and drawing, it is also a great display piece at home.

Order Code	Colour	Barcode
MD S6519BK	Black	
MD S6519BL	Blue	
MD S6519PK	Pink	
MD S6519RD	Red	
MD S6519WT	White	



Mozart



Marseille



Beethoven



Lyre Lady



Old Man



Apollo



KCK Masters Cast Model

KCK Masters Cast Model are scaled down proportionately to inherit the classics and masterpieces. Built with plaster. This Master Cast Model is suitable for beginners and art students studying the structure of the human face in-depth by practising face proportions in different angles, form and shading. Suitable for on-the-go painting/sketching and figure drawing lessons. Not only is this Master Cast Model great as a tool for sketching and drawing, it is also a great display piece at home.

Order Code	Type	Barcode
MD S6507WT	Old Man	
MD S6508WT	Marseille	
MD S9506WT	Beethoven	
MD S9507WT	Mozart	
MD S9508WT	Apollo	
MD S9509WT	Lyre Lady	
MD S6523WT	Moliere	





MARVY®
LICHTIDA
FOR DRAWING
ITEM NO. 4600
1.0

...nologies seeks
...ologies
...wards the
...ment
...ng using technology to
...onds and
... a lo



Marvy Uchida Drawing Pen (MA 4600)

Marvy Uchida Drawing Pens are fine point water-based pigmented ink pens. Available in sizes from 0.03mm to 1.0 mm & a brush, these pens are water-based, lightfast and water-proof. It comes in two different colours, Black & Brown. Archival in quality, Marvy Drawing Pens are ideal for technical drawing, detailed artworks, sketching, organisers & diaries. Acid-free, non-toxic & photosafe. Made in Japan

2 Colours



- water-based pigment
- pigmented & opaque
- permanent when dry
- Acid-free, Non-Toxic, Smudge Proof

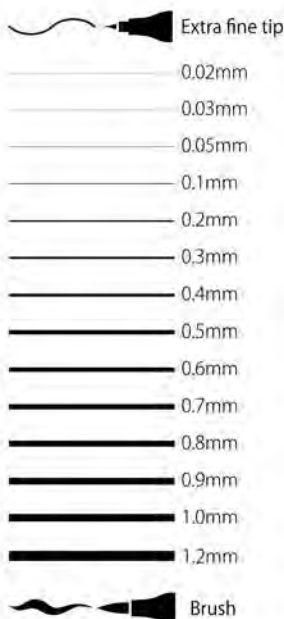

Order Code	Size	Barcode
MA 4600-002	0.02mm	
MA 4600-003	0.03mm	
MA 4600-005	0.05mm	
MA 4600-01	0.1mm	
MA 4600-02	0.2mm	
MA 4600-03	0.3mm	
MA 4600-04	0.4mm	
MA 4600-05	0.5mm	
MA 4600-06	0.6mm	
MA 4600-07	0.7mm	
MA 4600-08	0.8mm	
MA 4600-09	0.9mm	
MA 4600-1	1.0mm	
MA 4600-12	1.2mm	
MA 4600-B	Brush	

Order Code	Size	Barcode
MA 4600BR-003	0.03mm	
MA 4600BR-005	0.05mm	
MA 4600BR-01	0.1mm	
MA 4600BR-02	0.2mm	
MA 4600BR-03	0.3mm	
MA 4600BR-04	0.4mm	
MA 4600BR-05	0.5mm	
MA 4600BR-06	0.6mm	
MA 4600BR-07	0.7mm	
MA 4600BR-08	0.8mm	
MA 4600BR-09	0.9mm	
MA 4600BR-1	1.0mm	
MA 4600BR-B	Brush	



MARVY[®]
UCHIDA
For Sketching S
From No. 2000000 Grey tone

Yivian (aka...)

STREET VIEW



Marvy Drawing Pen Set 6's - Grey Tone
MA 4600-6A

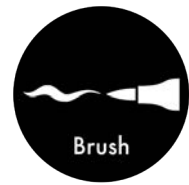

Marvy Drawing Pen Set 6's - Brown Tone
MA 4600-6B

2 Colours



- water-based pigment
- pigmented & opaque
- permanent when dry
- Acid-free, Non-Toxic, Smudge Proof

Marvy Uchida Drawing Pen Set 6's (MA 4600)

Marvy Drawing Pen Set showcases 2 sets of Brush Pen in colours Brown and Grey. Each set contains brush pens with their specified colours from a light-tone to a dark-tone of each colour. This water-based pigment, acid-free and non-toxic ink made from Japan is suitable for Calligraphy, Drawing, and Sketching.



Artwork by Vivian Loh

Lavender

bag bag bag bag bag



Orchid

bag bag bag bag bag



Pink

bag bag bag bag bag



Orange

bag bag bag bag bag



Red

bag bag bag bag bag



Light Green

bag bag bag bag bag



Green

bag bag bag bag bag



Olive Green

bag bag bag bag bag



Teal

bag bag bag bag bag



Light Blue

bag bag bag bag bag



Periwinkle

bag bag bag bag bag



Amethyst

bag bag bag bag bag



Blue

bag bag bag bag bag



Oriental Blue

bag bag bag bag bag



Burgundy

bag bag bag bag bag



Brown

bag bag bag bag bag



Dark Grey

bag bag bag bag bag



Black

bag bag bag bag bag





0.3mm tip

Marvy Uchida Le Pen (MA 4300)

This Made-In-Japan pen is made up of water-based pigments that is acid-free and non-toxic. The pigmented and opaque ink becomes permanent when dry making it smudge-proof. Available in 18 colours, this pen has a 0.3mm tip micro-fine plastic point that allows for smooth and precise accuracy. Perfect for scrapbooking, journaling and cardmaking. Available in 18 colours and 1 Pastel Set.



+ 1 Set



Marvy Le Pen Pastel Set 6's (MA 4300-6P)



Order Code	Colour	Barcode
MA 4300-08	Lavender	
MA 4300-78	Orchid	
MA 4300-09	Pink	
MA 4300-07	Orange	
MA 4300-02	Red	
MA 4300-11	Light Green	
MA 4300-04	Green	
MA 4300-15	Olive Green	
MA 4300-73	Teal	
MA 4300-10	Light Blue	
MA 4300-99	Periwinkle	
MA 4300-106	Amethyst	
MA 4300-03	Blue	
MA 4300-33	Oriental Blue	
MA 4300-28	Burgundy	
MA 4300-06	Brown	
MA 4300-21	Dark Grey	
MA 4300-01	Black	
MA 4300-6P	Pastel Set 6's	

Medium Red



Superfine Red



Medium Green



Superfine Green



Medium Blue



Superfine Blue



Medium Black



Superfine Black





0.3mm tip



3mm tip

4 Colours:

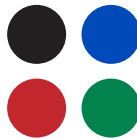

Marvy Uchida Multi Permanent Marker (MA 2600)

This Made-In-Japan permanent marker is made up of alcohol-based pigment. These acid-free and non-toxic permanent markers are suitable on multi surfaces such as CD, glass, metal, paper and other surfaces. This multi-surface marker is opaque, waterproof, smudge-proof & dries permanent instantly, making it great for use from medium to smooth surfaces. These Marvy Uchida Multi Markers are available in both superfine and medium point markers with colours like Red, Green, Blue, and Black to choose from.



Extra Fine



Bullet



Medium Tip on smooth surface







Superfine Tip on semi-smooth surface

Extra - Fine 

Colour	Order Code	Barcode
Black	MA 2600S-BK	
Blue	MA 2600S-BL	
Green	MA 2600S-GN	
Red	MA 2600S-RD	



Bullet 

Colour	Order Code	Barcode
Black	MA 2600M-BK	
Blue	MA 2600M-BL	
Green	MA 2600M-GN	
Red	MA 2600M-RD	



Marvy Uchida Artist Brush (MA 1100)

Perfect for sketching, calligraphy artworks & fashion illustrations! Create new colours that add depth to your artwork with highlights and shadows. Marvy Uchida Artist Brush blends easily and dries quickly. Available in 70 Colours and 1 Colourless Blender that blends any other colour from the range and also removes any unwanted tones. Soft and elastic brush, water-based ink, Made in Japan.



flexible felt brush tip



water-based dye



+ Blender

Colour	Order Code	Barcode
Pale Pink	MA 1100-47	
Blush Pink	MA 1100-76	
Pastel Peach	MA 1100-77	
Pale Orange	MA 1100-16	
Pale Mauve	MA 1100-81	
Bubble Gum Pink	MA 1100-67	
Rose Pink	MA 1100-57	
Wisteria	MA 1100-62	
Cream Yellow	MA 1100-42	
Daffodil Yellow	MA 1100-68	
Lemon Yellow	MA 1100-22	
Yellow	MA 1100-5	
Brilliant Yellow	MA 1100-43	
Butterscotch	MA 1100-83	
Orange	MA 1100-7	
Vermillion	MA 1100-49	
Coral Pink	MA 1100-35	
Rosemarie	MA 1100-59	
Pink	MA 1100-9	
Carmin	MA 1100-19	
Red	MA 1100-2	
Violet	MA 1100-8	
Pale Violet	MA 1100-31	
Salvia Blue	MA 1100-60	

Colour	Order Code	Barcode
Magenta	MA 1100-20	
Iris Purple	MA 1100-55	
Aquamarine	MA 1100-74	
Pale Blue	MA 1100-53	
Manganese Blue	MA 1100-36	
Light Blue	MA 1100-10	
Dull Blue	MA 1100-56	
Steel Blue	MA 1100-17	
Blue	MA 1100-3	
Prussian Blue	MA 1100-29	
Ultramarine	MA 1100-50	
Oriental Blue	MA 1100-33	
Blue Grey	MA 1100-41	
Peppermint	MA 1100-70	
Pale Green	MA 1100-34	
Laurel Green	MA 1100-32	
Peacock Green	MA 1100-58	
Olive Green	MA 1100-15	
Jungle Green	MA 1100-96	
Yellow Green	MA 1100-52	
Light Green	MA 1100-11	
Leaf Green	MA 1100-48	
Tuquoise	MA 1100-14	
Green	MA 1100-4	

Colour	Order Code	Barcode
Bottle Green	MA 1100-25	
Beige	MA 1100-24	
Rosewood	MA 1100-30	
Brown Light	MA 1100-44	
Ochre	MA 1100-13	
Gold Ochre	MA 1100-23	
Olive Brown	MA 1100-27	
Brown Red	MA 1100-6	
Crimson Lake	MA 1100-46	
English Red	MA 1100-28	
Burnt Umber	MA 1100-54	
Sepia	MA 1100-45	
Dark Brown	MA 1100-18	
Aqua Grey	MA 1100-51	
Celadon	MA 1100-95	
Light Cool Grey	MA 1100-37	
Oyster Grey	MA 1100-38	
Silver Grey	MA 1100-26	
Ash Grey	MA 1100-39	
Grey	MA 1100-12	
Brownish Grey	MA 1100-40	
Dark Grey	MA 1100-21	
Black	MA 1100-1	
Blender	MA 1100-0	



Primary Set



Vivid Set



Bright Set

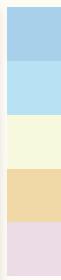

Pale Set



Natural Set



Deep Set



Dull Set



Grey Set



Brown Set



Earth Set



Floral Set



Harmony Set



Baby Set



Botanical Set

Marvy Uchida Artist Brush Sets (MA 1100)

Perfect for sketching, calligraphy artworks & fashion illustrations! This Marvy Uchida Brushes also comes in sets of 5. Available in 14 ranges/themes of colours, they are available according to your different needs. The water-based dye brushes have flexible tips that perform ideally when blending the colours. Made in Japan. The water-based ink and soft elastic brush tip blends easily and dries quickly.



Water-based dye



Flexible felt brush tip



Artwork by Vivian Loh

Colour	Order Code	Barcode
Primary	MA 1100-5A	
Vivid	MA 1100-5B	
Bright	MA 1100-5C	
Pale	MA 1100-5D	
Natural	MA 1100-5E	
Deep	MA 1100-5F	
Dull	MA 1100-5G	
Grey	MA 1100-5H	
Brown	MA 1100-5I	
Earth	MA 1100-5J	
Floral	MA 1100-5K	
Harmony	MA 1100-5L	
Baby	MA 1100-5M	



chisel
DecoColor™
ACRYLIC PAINT

chisel
DecoColor™
ACRYLIC PAINT



Marvy Uchida DecoColor Acrylic Markers (MA 3155)

Decocolour markers are made up of Xylene-based pigment with high opaqueness and vivid colors. Suitable on wood, metal, and various kinds of surfaces; Ideal for Paper crafting, Multi Surfaces, Home Decor. The Chiseled Tip Model Decocolour Markers are available in 28 Colours with 6 Metallic Colours while The Extra Wide Tip Decocolour Markers comes in 9 Colours with 2 Metallic Colours.



Artwork done on:
KCK Studio Collection 135gsm
Cold Pressed Drawing Paper



DecoColor on Semi-Smooth
& Rough Surface



Chisel	Colour	Order Code	Barcode
	White	MA 3155-0	
	Pale Orange	MA 3155-16	
	Bubble Gum Pink	MA 3155-67	
	Wisteria	MA 3155-62	
	Yellow	MA 3155-5	
	Orange	MA 3155-7	
	Pumpkin	MA 3155-87	
	Pink	MA 3155-9	
	Red	MA 3155-2	
	Light Blue	MA 3155-10	
	Blue	MA 3155-3	
	Violet	MA 3155-8	
	Aquamarine	MA 3155-74	
	Celadon	MA 3155-95	
	Jade Green	MA 3155-102	
	Celery	MA 3155-92	
	Light Green	MA 3155-11	
	Green	MA 3155-4	
	Aubergine	MA 3155-93	
	English Red	MA 3155-28	
	Brown	MA 3155-6	
	Black	MA 3155-1	
	Gold	MA 3155-GLD	
	Silver	MA 3155-SLV	
	Metallic Red	MA 3155-MRD	
	Metallic Blue	MA 3155-MBL	
	Metallic Green	MA 3155-MGN	
	Metallic Violet	MA 3155-MVL	

Extra - Wide	Colour	Order Code	Barcode
	White	MA 4155-0	
	Black	MA 4155-1	
	Red	MA 4155-2	
	Blue	MA 4155-3	
	Green	MA 4155-4	
	Yellow	MA 4155-5	
	Brown	MA 4155-6	
	Gold	MA 4155-GLD	
	Silver	MA 4155-SLV	





Broad
5mm



Fine
3mm



X-Fine
1mm



DecoColor Industrial Paint on
Pebble & Clay



Marvy Uchida Industrial Paint Marker (MA 221)

Made-in-Japan quality permanent marker, Marvy Uchida Industrial Paint Markers are available in extra fine, fine and bullet point markers. Comes in 11 Colours, Marvy Uchida's Industrial Paint Markers are suitable on Multi Surfaces such as metal, wood, glass, clay and other surfaces. Ink made up of xylene-based pigment that is acid-free and non-toxic. Waterproof & Dries Instantly. Making it great for use from semi rough to smooth surfaces.

Extra - Fine



Colour	Order Code	Barcode
Black	MA 120GD	
Blue	MA 120S	
Violet	MA 130WT	
Light Blue	MA 140BK	
Pale Blue	MA 140BL	
Blush Pink	MA 140BP	
Pink	MA 140CY	
Green	MA 140GR	
C.Yellow	MA 140LB	
Gold	MA 140PB	
Silver	MA 140PK	
White	MA 140PM	

Fine



Colour	Order Code	Barcode
Black	MA 221BK	
Blue	MA 221BL	
Violet	MA 221VL	
Brown	MA 221BR	
Red	MA 221RD	
Pink	MA 221PK	
Green	MA 221GR	
Yellow	MA 221YL	
Gold	MA 221GL	
Silver	MA 221SL	
White	MA 221WT	

Bullet



Colour	Order Code	Barcode
Black	MA 728BK	
Blue	MA 728BL	
Violet	MA 728VL	
Brown	MA 728BR	
Red	MA 728RD	
Pink	MA 728PK	
Green	MA 728GR	
Yellow	MA 728YL	
Gold	MA 728GL	
Silver	MA 728SL	
White	MA 728WT	



Marvy Uchida Fabric Marker Set (MA 560)

Marvy Uchida's Fabric Marker is made up of water-based pigment that is odourless, acid-free and non-toxic. Suitable for Arts & Craft Projects, revamping unused clothing to new ones and upcycling fabric for mixed media techniques. This conic-shape tip is good for both painting wide areas on light coloured fabric. No Ironing is needed as the pigment will become permanent after washed & dried. Made in Japan.



Primary Set (MA 560-6A)



Pastel Set (MA 560-6B)



Fluorescent Set (MA 560-6C)



3 Sets

- Primary
- Pastel
- Fluorescent

Order Code	Colour	Barcode
MA 560-6A	Primary	
MA 560-6B	Pastel	
MA 560-6C	Fluorescent	





Marvy Uchida Calligraphy Pen (MA 6000)

Marvy Calligraphy Pen has a range of flat nib pen with made in Japan quality. These markers are great for greeting cards, invitations and any paper crafting project. Available only in Black colour. these markers are a must have for any calligraphy kit. Made up of water-based dye, this acid-free, non-toxic pens are pigmented and smudgeproof when dry. These calligraphy pens comes in 2.0, 3.5, and 5.0mm point sizes allowing for a variety in lettering.

Order Code	Colour	Barcode
MA 6000-20	Black	
MA 6000-35	Black	
MA 6000-50	Black	



Marvy Uchida Neo & Chalk marker Set 6's (MA 490-6C)

Marvy Neo & Chalk Marker, made up of water-based pigment, this acid-free, non-toxic Markers makes it suitable to be used in a Classroom, on a Window, Signboard and Home Decorations. This marker's pigment will glow under blue light and easily erased with dry cloth. This Neo & Chalk Marker Set comes in 6 Neon Colours.

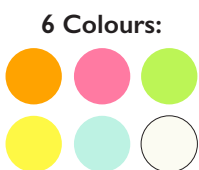

Order Code	Colour	Barcode
MA 490-6C	Neo & Chalk	

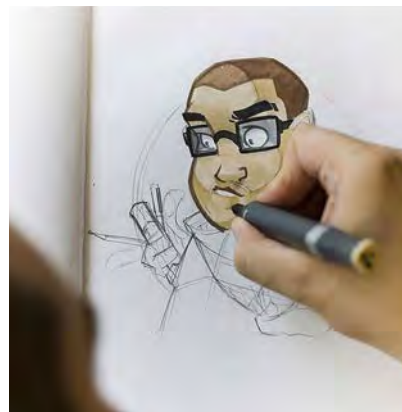

Alpha Alcohol Design Marker

A Made-in-Korea Quality, this alcohol-based ink marker comes in two different nibs, fine and chiseled. The two different nibs give the allowance of sharp broad, thin, and long lines. Available in 200 colours including 3 ranges of grey; Warm, Cool, and Neutral toned greys. Archival in quality, Alpha Alcohol Markers are ideal for technical drawing, detailed artworks, sketching & journaling. Nibs are replaceable. Non-toxic and safe according to American Standard (ASTM D4236)



MADE IN KOREA

































Colour Name	Order Code	Barcode
Mint Blue	AC AMB124	
Fair Aqua	AC AMB142	
River Blue	AC AMB133	
Light Cyan	AC AMB113	
Pale Blue	AC AMB152	
Baby Blue	AC AMB163	
Ice Blue	AC AMB161	
Pale Ultramarine	AC AMB154	
Sky Blue	AC AMB126	
Cyan	AC AMB115	
Light Blue	AC AMB135	
Manganese Blue	AC AMB164	
Brilliant Blue	AC AMB136	
Process Blue	AC AMB128	
Peacock Blue	AC AMB129	
Ultramarine Light	AC AMB157	
Ultramarine	AC AMB159	
Bright Blue	AC AMB138	
Indigo	AC AMB167	
Prussian Blue	AC AMB169	
Celadon	AC AMG181	
Pale Aqua	AC AMG162	
Mint Green	AC AMG165	
Aqua	AC AMG166	

Colour Name	Order Code	Barcode
Dark Aqua	AC AMG169	
Dark Turquoise	AC AMB118	
Light Pine Green	AC AMG158	
Vivid Blue	AC AMB148	
Malachite	AC AMG137	
Fresh Ash	AC AMG154	
Pale Green	AC AMG134	
Lime	AC AMG153	
Lime Punch	AC AMG132	
Yellow Green Light	AC AMG113	
Yellow Green	AC AMG114	
Elm Green	AC AMG115	
Lawn Green	AC AMG117	
Natural Green	AC AMG123	
Fresh Green	AC AMG125	
Greenery	AC AMG146	
Leaf Green	AC AMG127	
Medium Green	AC AMG148	
Vivid Green	AC AMG128	
Virdian	AC AMG139	
Pine Green	AC AMG159	
Forest Green	AC AMG184	
Lime Green	AC AMG182	
Moss	AC AMG187	

Colour Name	Order Code	Barcode
Bright Parrot Green	AC AMG259	
Deep Olive Green	AC AMG189	
Marine Green	AC AMG178	
Pine Needle	AC AMG289	
Spanish Olive	AC AMG176	
Olive	AC AMG177	
Pale Olive	AC AMG175	
Mellow Olive	AC AMG172	
Sun Kiss	AC AMR111	
Light Peach	AC AMR113	
Pale Peach	AC AMR132	
Pink Snow	AC AMV162	
Peach	AC AMR134	
Light Pink	AC AMV111	
Coral	AC AMR137	
Red Orange	AC AMR156	
Sugar Coral	AC AMR125	
Coral Rose	AC AMR114	
Vermillion	AC AMR117	
Hot Coral	AC AMR119	
Scarlet	AC AMR129	
Carmine	AC AMR147	
Crimson	AC AMR138	
Cardinal	AC AMR148	

Colour Name	Order Code	Barcode
Cardinal	AC AMR148	
Magenta	AC AMV118	
Red Violet Deep	AC AMV329	
Red Violet	AC AMV129	
Rose	AC AMV127	
Light Rose	AC AMV125	
Bright Pink	AC AMV117	
Light Magenta	AC AMV115	
Pink	AC AMV112	
Dark Pink	AC AMV164	
Lilac	AC AMV134	
Iris Purple	AC AMV166	
Orchid Ice	AC AMV152	
Violet	AC AMV139	
Light Violet	AC AMV142	
Gray Lilac	AC AMV154	
Orchid	AC AMV182	
Rosebud	AC AMV185	
Vivid Purple	AC AMV229	
Burgundy	AC AMR167	
Bluish Lavender	AC AMV187	
Deep Violet	AC AMV137	
Blue Violet	AC AMV149	
Cobalt Violet	AC AMV173	
Lavender	AC AMV147	
Jacaranda	AC AMV146	
Walnut	AC AMW179	
Bronze	AC AMW189	
Cacao	AC AMW139	
Vandyke Brown	AC AMW169	
Burnt Umber	AC AMW137	
Lipstick Natural	AC AMW153	
Light Camel	AC AMW105	
Chocolate	AC AMW136	
Peach Whip	AC AMW103	
Grayish Brown	AC AMW175	
Raw Sienna	AC AMW184	
Sepia	AC AMW148	
Almond	AC AMW124	
Light Chocolate	AC AMW135	
Sand Storm	AC AMW165	
Fall Leaf	AC AMW164	
Pebble	AC AMW174	
Pale Khaki	AC AMW173	
Brick Beige	AC AMW143	
Jaune Brilliant	AC AMW102	
Nude	AC AMW122	
Vanilla	AC AMW101	

Colour Name	Order Code	Barcode
Bridal Skin	AC AMW131	
Wood Ash	AC AMW163	
Ivory Cream	AC AMW100	
Cloud Cream	AC AMW171	
Chalk	AC AMW170	
Light Wood	AC AMW113	
Medium Wood	AC AMW115	
Peach Skin	AC AMW154	
Light Mahogany	AC AMW158	
Sienna	AC AMW119	
Burnt Sienna	AC AMW157	
Brick	AC AMW128	
Red Ochre	AC AMY159	
Fresh Vermillion	AC AMY158	
Cadmium Orange	AC AMY157	
Yellow Orange	AC AMY154	
Citrus	AC AMY149	
Imperial Yellow	AC AMY148	
Acid Yellow	AC AMY144	
Cadmium Yellow	AC AMY114	
Bright Yellow	AC AMY143	
Lemon Chrome	AC AMY141	
Lemon Yellow	AC AMY113	
Sunshine	AC AMY140	
Pale Yellow	AC AMY112	
Naples Yellow	AC AMY123	
Banana Crepe	AC AMY133	
Naples Yellow Deep	AC AMY125	
Brown Gray	AC AMW181	
Mustard	AC AMY126	
Sunset Gold	AC AMY162	
Golden Yellow	AC AMY116	
Saffron	AC AMY164	
Yellow Ochre	AC AMY135	
Yellow Ochre Deep	AC AMY137	
Caramel	AC AMY138	
Colorless	AC AMOO	
Toner Gray 01	AC AMTG01	
Toner Gray 02	AC AMTG02	
Toner Gray 03	AC AMTG03	
Toner Gray 04	AC AMTG04	
Toner Gray 05	AC AMTG05	
Toner Gray 06	AC AMTG06	
Toner Gray 07	AC AMTG07	
Toner Gray 08	AC AMTG08	
Toner Gray 09	AC AMTG09	
Toner Gray 10	AC AMTG10	

Colour Name	Order Code	Barcode
Cool Gray 01	AC AMCG01	
Cool Gray 02	AC AMCG02	
Cool Gray 03	AC AMCG03	
Cool Gray 04	AC AMCG04	
Cool Gray 05	AC AMCG05	
Cool Gray 06	AC AMCG06	
Cool Gray 07	AC AMCG07	
Cool Gray 08	AC AMCG08	
Cool Gray 09	AC AMCG09	
Cool Gray 10	AC AMCG10	
Neutral Gray 01	AC AMNG01	
Neutral Gray 02	AC AMNG02	
Neutral Gray 03	AC AMNG03	
Neutral Gray 04	AC AMNG04	
Neutral Gray 05	AC AMNG05	
Neutral Gray 06	AC AMNG06	
Neutral Gray 07	AC AMNG07	
Neutral Gray 08	AC AMNG08	
Neutral Gray 09	AC AMNG09	
Neutral Gray 10	AC AMNG10	
Warm Gray 01	AC AMWG01	
Warm Gray 02	AC AMWG02	
Warm Gray 03	AC AMWG03	
Warm Gray 04	AC AMWG04	
Warm Gray 05	AC AMWG05	
Warm Gray 06	AC AMWG06	
Warm Gray 07	AC AMWG07	
Warm Gray 08	AC AMWG08	
Warm Gray 09	AC AMWG09	
Warm Gray 10	AC AMWG10	
Black	AC AMI20	
Special Black	AC AMI21	
Colorless	AC AMOO	



Alpha Alcohol Marker Design Marker 12C (AC AM12C-A)

- 12 Colours
- Soft & Durable Nibs
- Alcohol-Based Ink
- Fast Drying
- Acid-free, Non-Toxic



Alpha Alcohol Marker Design Marker 24C (AC AM24C)

- 24 Colours
- Soft & Durable Nibs
- Alcohol-Based Ink
- Fast Drying
- Acid-free, Non-Toxic



Alpha Alcohol Marker Design Marker 36C (AC AM36C)

- 36 Colours
- Soft & Durable Nibs
- Alcohol-Based Ink
- Fast Drying
- Acid-free, Non-Toxic



Alpha Alcohol Marker Design Marker 60C (AC AM60C)

- 60 Colours
- Soft & Durable Nibs
- Alcohol-Based Ink
- Fast Drying
- Acid-free, Non-Toxic



Alpha Design Marker Set

A Made-in-Korea Quality, this alcohol-based ink marker comes in 4 sets. Available in 12, 24, 36, and 60 Colours. Archival in quality, Alpha Alcohol Markers are ideal for technical drawing, detailed artworks, sketching & journaling. Nibs are replaceable. Non-toxic and safe according to American Standard (ASTM D4236)

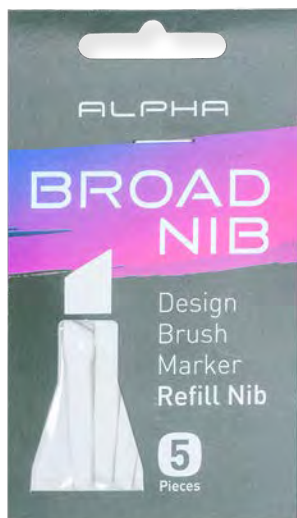

Alpha Design Marker Interchangeable Nibs - Broad (AC AMT-B)

- 5 Pieces
- Soft & Durable Nibs
- Broad Nibs



Alpha Interchangeable Nibs

A Made-in-Korea Quality, Alpha Interchangeable Nibs come in 3 different shapes of tips; Broad, Brush & Fine Nibs. Replacing the nibs allow for a longer-lasting and durable marker. These interchangeable nibs are versatile and convenient as the markers are able to be replaced with different style nibs across the range. This allows for a more eco-friendly, less wastage and cost-effective way of making art.



Alpha Design Marker Interchangeable Nibs - Brush (AC AMT-BR)

- 3 Pieces
- Soft & Durable Nibs
- Brush Nibs

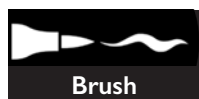

Order Code	Colour	Barcode
ACAMT-B	Broad	
ACAMT-BR	Brush	
ACAMT-F	Fine	



Alpha Design Marker Interchangeable Nibs - Fine (AC AMT-F)

- 5 Pieces
- Soft & Durable Nibs
- Fine Nibs

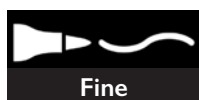



Sketching



Cartoon



Design

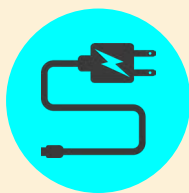

AC Adapter

This Marvy Tracing Board is ideal for stenciling, 2D animation, calligraphy, embossing, scrapbooking, tattoo transferring, sketching & drawing, streaming, sewing projects, stained glass, quilting X-ray viewing, etc. With a brightness of over 2,700 lux, Marvy's Tracing Board lights bright enough to see through thicker pieces of paper. It comes in two sizes that fit A4 & B4 Sized paper in the Tracing Surfaces. This model of tracing board is well-built and promises a lifespan of 50,000hours. Suitable for all tracing needs.



Book 3 - Drawing & Sketches



PLEASE RECYCLE

www.kck.sg



PAPER & PADS



BOOK FOUR

Introduction

Choong Marketing was established in 1998 by Mr K C Kang. We are an importer/exporter and distributor of stationery and art-based materials in Singapore. Since then, it is our company mission to supply our customers with quality products. Over the years we have grown at a steady pace; increasing product range, brand representation and channels to customers. As we continue to grow, we will continue to strengthen our position by working with partners with shared values and not forgetting our mission of providing ordinary products with extraordinary quality.

Manufacturing

We manufacture the DREAM brand in our own facilities and other than the regular selections, we can work with different customers on their own brand and specifications.

The Brands

If people are the company's right hand, the brands and partners would surely be its left hand. We value every brand we represent and it's our preference to work with brands that complement each other so that we would be able to grow in strength together. The following are brands that we represent exclusively:

•AMOS •CARIOCA •DREAM
•KANGARO •KCK QUALITY •KCK CRAFT
•KEBA KUM •MARVY UCHIDA •MONTANA CANS
•PLAY •SADIPAL •SIO-2 •KUSAKABE •SENNELIER
•PAPA CLAY •ALPHA COLOURS •YOUNG ARTIST

Contents

Pg 4-5	Watercolour Loose Papers
Pg 6-9	Watercolour Paper Pads & Circle Paper
Pg 10-15	Eco Packs & Paper Roll
Pg 16-19	Drawing & Sketching Pads
Pg 20-27	Drawing & Sketching Loose Papers
Pg 26-29	Sketchbooks & Journals
Pg 30-37	Pastel, Construction, Kraft & Tracing Paper
Pg 38-43	Cork Sheet, Mounting Boards & Black Card
Pg 44-45	Journal Customisation

DREAM®

Artist Watercolor Paper Series 4
Paper made in Italy with 100% cotton, natural color and texture.
Behind every masterpiece is a story and
behind every captured story
there is DREAM.

A4

210 mm x 297 mm

5 Sheets
5 fogli, 5 feuilles, 5 Blatt, 5 hojas

300 g/m²
300 g/m²

100% Cotton
100% cotone, 100% coton, 100% cotton

Acid Free
senza acido, acide libre, sans acide, libre de acido

Cold Pressed
granata, gran fin, kallipresset, presetto en frío

FSC Certified
FSC - certificato, certifié, certificado

Mould Made Paper
Paper Made in Italy
modellato a mano, a mano made, Fata-Blattus Paper, papel elaborado con mariposas reboadas
by one of the oldest fine art paper mill since 1264



product by:



www.kek.sg

DREAM®

Artist Watercolor Paper Series 4
Paper made in Italy with 100% cotton, natural color and texture.
Behind every masterpiece is a story and
behind every captured story
there is DREAM.

A5

5 Sheets
5 fogli, 5 feuilles, 5 Blatt, 5 hojas

300 g/m²
300 g/m²

100% Cotton
100% cotone, 100% coton, 100% cotton

Acid Free
senza acido, acide libre, sans acide, libre de acido

Cold Pressed
granata, gran fin, kallipresset, presetto en frío

FSC Certified
FSC - certificato, certifié, certificado

Mould Made Paper
Paper Made in Italy
modellato a mano, a mano made, Fata-Blattus Paper, papel elaborado con mariposas reboadas
by one of the oldest fine art paper mill since 1264



product by:



www.kek.sg

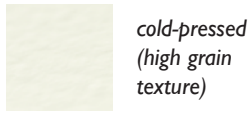
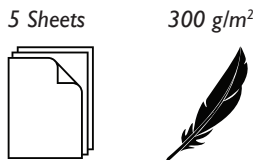

DREAM© Watercolour Paper - Mould Made

Dream© Mould Made Watercolour Paper is manufactured with 100% cotton liners for enhanced surface durability. It is an excellent surface for artists that would like to create a fine art piece that will last. This paper has a high grain texture and deckle edges that give the paper a beautiful surface. Ideal for wet mediums like Watercolour, Gouache, Tempera, Acrylic.

Order Code	Size	Barcode
S4WCL300A5-05	A5	
S4WCL300A4-05	A4	
S4WCL300A3-05	A3	
S4WCL300A2-05	A2	

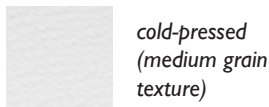
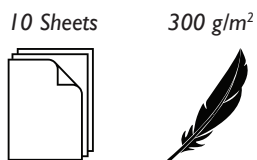

DREAM© Watercolour Paper - Cold Pressed

Dream© Watercolour Paper Cold Pressed Paper is made from 25% Cotton Fiber and lignin-free cellulose pulp. This paper has a fine to medium texture with excellent absorbency. Suitable for watercolour, tempera, Gouache, acrylic, ink & mixed media techniques. This paper is ideal for beginners or art students to explore with both larger areas of wash and fine details.

Order Code	Size	Barcode
WCL300A5-10	A5	
WCL300A4-10	A4	
WCL300A3-10	A3	
WCL300A2-10	A2	

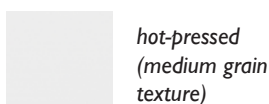
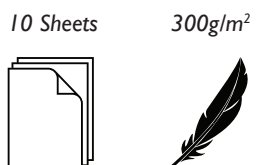

DREAM© Watercolour Paper - Hot Pressed

Dream© Watercolour Paper Hot Pressed Paper is made from 25% Cotton Fiber and lignin-free cellulose pulp. This paper has a fine to smooth matte texture that is excellent for mixed media techniques and creating highly detailed artworks in a variety of media. Suitable for watercolour, tempera, Gouache, acrylic, ink & mixed media techniques.

Order Code	Size	Barcode
WHL300A5-10	A5	
WHL300A4-10	A4	
WHL300A3-10	A3	
WHL300A2-10	A2	



...Paper Series I
natural colour and texture.
Colourist

DREAM[®]
Artist Watercolor Paper
Behind every masterpiece is a story and
behind every captured story
there is DREAM.

BIG
SAVINGS
PACK

Watercolor Series I
acquerello aquarelle acuarela

DREA
Artist Watercolor Paper
Behind every masterpiece is a story and
behind every captured story
there is DREAM.





DREAM© Watercolour Paper - Series I (Stitched Pad)





Dream© Watercolour Paper - Stitched Pad is available in a thread-bounded journal of 6 sheets, with another watercolour paper as its cover. In total, this pad has 11 open spreads and 22 pages. The weight of the paper is 300gsm, making it ideal for watercolour, tempera, gouache, acrylic, ink & mixed media techniques. Available in A5, A5L, A4, and A4L sizes. Italian-Made, these watercolour papers are produced with 25% of lignin-free cotton and acid-free cellulose. The paper is also made from 100% E.C.F. pulp (Elemental Chlorine Free) and is F.S.C certified from a well-managed forest that meets the highest environmental and social standards.

 6 Sheets
  300g/m²









Order Code	Size	Barcode
WCB300A5-20	A5	
WCB300A5L-20	A5L	
WCB300A4-20	A4	
WCB300A4L-20	A4L	



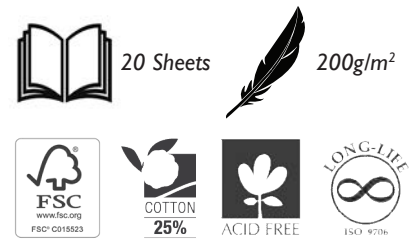

DREAM© Watercolour Paper - Series I (200g/m²)

Dream© Watercolour Paper Gummed Pad is available in a gummed pad of 20 Sheets, with a hardback at the bottom that serves as additional support while drawing or painting. Made up of medium texture, cold-pressed with a weight of 200gsm, making it ideal for watercolour, tempera, Gouache, acrylic, ink & mixed media techniques. Available in A5, A4, and A3 sizes. The paper is also made from 100% E.C.F. pulp (Elemental Chlorine Free) and is F.S.C certified from a well-managed forest that meets the highest environmental and social standards.



Order Code	Size	Barcode
WCP200A5-20	A5	
WCP200A4-20	A4	
WCP200A3-20	A3	





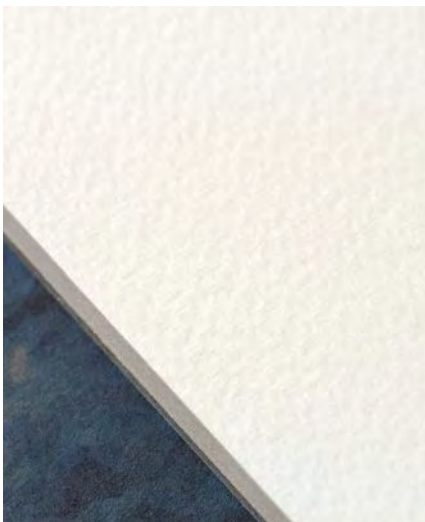

DREAM© Watercolour Paper - Series I (300g/m²)

Dream© Watercolour Paper Gummed Pad is available in a gummed pad of 15 Sheets, with a hardback at the bottom that serves as additional support while drawing or painting. Made up of medium texture, cold-pressed with a weight of 300gsm, making it ideal for watercolour, tempera, Gouache, acrylic, ink & mixed media techniques. Available in A4, A3, and A2 sizes. The paper is also made from 100% E.C.F. pulp (Elemental Chlorine Free) and is F.S.C certified from a well-managed forest that meets the highest environmental and social standards.



Order Code	Size	Barcode
WCP300A4-15	A4	
WCP300A3-15	A3	
WCP300A2-15	A2	







DREAM© Circle Watercolour Paper - 25cm

Dream© Circle Watercolour Paper consists of 5 and 10 pieces of circular-shaped, loose sheets. Made up of 300g/m², cold-pressed paper, this paper is available only in traditional white, made in Italy. Produced with 25% of lignin-free cotton and acid-free cellulose, this paper guarantees long performance over time. The paper is also made from 100% E.C.F. pulp (Elemental Chlorine Free) and is F.S.C certified from a well-managed forest that meets the highest environmental and social standards.

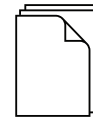

5 Sheets



300g/m²



Order Code	Size	Barcode
WCL300C025-05	A4	



BIG
SALVING
GO
CHECK

DREAM®
FINEST QUALITY PAPER SERIES

A5

100 Sheets

300 g/m²

25% Cotton

Acid Free

Cold Pressed

Paper Made in Italy
By one of the oldest fine-art paper mills since 1254



DREAM© Artist Watercolour Paper Series I - 100 Sheets

Dream Eco-Pack Artist Watercolour Paper is made up of Premium quality Paper in an economical pack of 100 Sheets. Produced with 25% of lignin-free cotton and acid-free cellulose, this 300g/m² paper guarantees long performance. The paper is also made from 100% E.C.F. pulp (Elemental Chlorine Free) and is F.S.C certified from a well-managed forest that meets the highest environmental and social standards. This paper is an ideal surface for watercolour, tempera, gouache, acrylic, ink and mixed media techniques.



Order Code	Size	Barcode
WCL200A5-100	A5	
WCL200A4-100	A4	
WCL200A3-100	A3	
WCL200A1	A1	
WCL300A5-100	A5	
WCL300A4-100	A4	
WCL300A3-100	A3	
WCL300A1	A1	

*Cutting Services is also available





DREAM© Artist Watercolour Paper Roll Series I

Dream© Artist Watercolour Paper Roll Series I measures in 1.5m x 10m long - an exceptional offer for schools, studios or fine art students. Produced with 25% of lignin-free cotton and acid-free cellulose, this 300g/m² paper guarantees long performance. The paper is also made from 100% E.C.F. pulp (Elemental Chlorine Free) and is F.S.C certified from a well-managed forest that meets the highest environmental and social standards. Suitable for watercolour, tempera, gouache, acrylic, ink and mixed media. Cutting Services is also available.

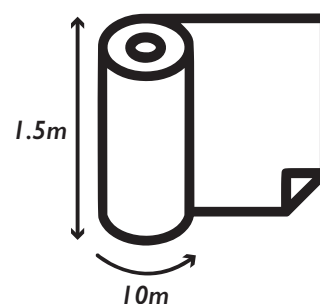

Order Code	Size	Barcode
DM 63001510	1.5 x 10m	



**Cutting Services is also available*





DREAM© Artist Drawing Paper Gummed Pad

Dream© Artist Drawing Paper Gummed Pad is made up of 40 sheets of fine to medium texture cold-pressed paper made in Italy. This 160 g/m² paper is available in traditional white. These sketchbooks are ideal for drawing with graphite/colour pencils, pen, marker, soft and oil pastels. Suitable for on-the-go and outdoor drawings due to its cardboard backing giving a stable surface for drawing. The gummed pad allows for a clean tear when done with an artwork.



Size	Order Code	Barcode
A4	ADPI60A4-40	







DREAM© Artist Graphite Pencil Sketch Pad

Dream© Artist Graphite Pencil Sketch Pad is available in a gummed pad of 30 Sheets, with a hardback at the bottom that serves as additional support while drawing or sketching. Made up of fine to medium texture, cold-pressed with a weight of 160 gsm, this paper is an ideal surface for graphite, charcoal, pastels, or colour pencils. Available in A4, A3, and A2 sizes. Made from 100% E.C.F pulp (Elemental Chlorine Free), this paper is F.S.C certified from a well-managed forest that meets the highest environmental and social standards.



Order Code	Size	Barcode
GCP160A4-30	A4	
GCP160A3-30	A3	
GCP160A2-30	A2	





DREAM© Artist Coloured Pencil Paper Sketch Pad

Dream© Artist Coloured Pencil Sketch Pad is available in a gummed pad of 30 Sheets, with a hardback at the bottom that serves an additional support while drawing or sketching. Made up of fine to medium texture, cold pressed with a weight of 165 gsm, this paper is an ideal surface for colour pencils. Available in A4, A3, and A2 sizes. Made from 100% E.C.F pulp (Elemental Chlorine Free), this paper is F.S.C certified from a well-managed forest that meets the highest environmental and social standards. Recommended to be used with KCK Blendmaestro Coloured Pencil.



Order Code	Size	Barcode
CCPI65A4-30	A4	
CCPI65A3-30	A3	
CCPI65A2-30	A2	









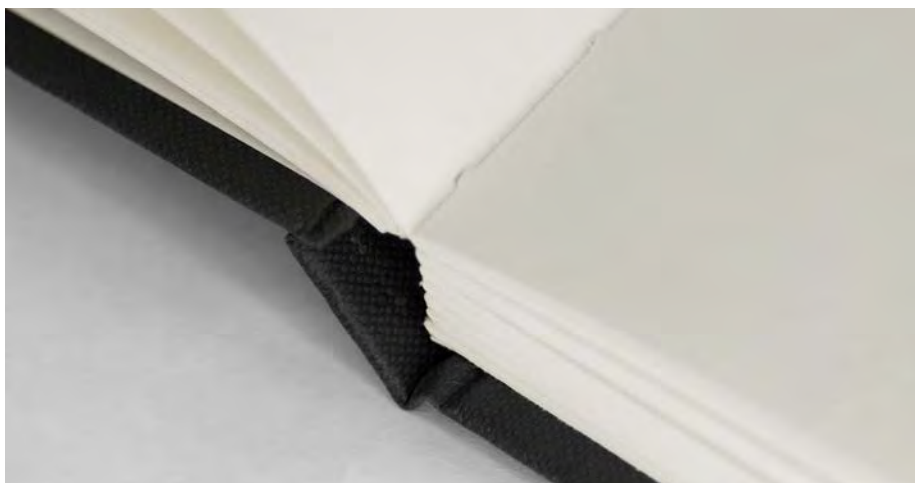
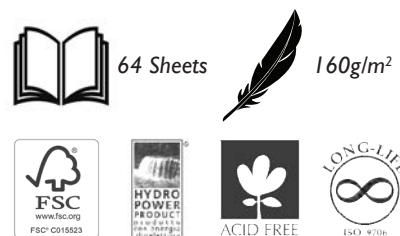











DREAM© Hardcover Artist Journals

Dream© Hardcover Artist Journals are made up of finely textured cold-pressed, 160g/m² of traditional white paper. These journals are available in 4 different cover colours and come in A5, A5L, A4 & A3 Sizes. These are premium quality sketchbooks ideal for drawing, sketching, and wet mediums such as watercolour, gouache, and acrylic paint. The 64 sheets of papers in these journals are Italian-made and acid-free. This journal is F.S.C certified as it comes from a well-managed forest that meets the highest environmental and social standards.



Colour	A5	Barcode
Black	JCPI 60A5-128	
Buff	JCPI 60A5-128BU	
Rino	JCPI 60A5-128RN	
Umber	JCPI 60A5-128UM	
Colour	A5L	Barcode
Black	JCPI 60A5L-128	
Buff	JCPI 60A5L-128BU	
Rino	JCPI 60A5L-128RN	
Umber	JCPI 60A5L-128UM	
Colour	A4	Barcode
Black	JCPI 60A4-128	
Buff	JCPI 60A4-128BU	
Rino	JCPI 60A4-128RN	
Umber	JCPI 60A4-128UM	
Colour	A3	Barcode
Black	JCPI 60A3-128	
Buff	JCPI 60A3-128BU	
Rino	JCPI 60A3-128RN	
Umber	JCPI 60A3-128UM	



DREAM© Artist Soft Sketch Journal

Dream© Artist Soft Sketch Journal is made up of finely textured, cold-pressed 120g/m² of traditional white paper. Available in A5/A4 Size and in 32/64 sheets, the paper is in a traditional white colour. These sketchbooks are ideal for dry mediums as it is light and designed for daily journaling, writing, and sketching. The papers in these journals are Italian-made, Acid-free, and FSC Certified. This paper is F.S.C certified as it comes from a well-managed forest that meets the highest environmental and social standards.



64 Sheets	Code	Barcode
A5 Size	JSS120A5-64BK	
A4 Size	JSS120A4-64BK	
128 Sheets	Code	Barcode
A5 Size	JSS120A5-128BK	
A4 Size	JSS120A4-128BK	

DREAM© Softcover Journal - 64 Sheets/ 160gsm

Dream© Artist Soft Sketch Journal is made up of finely textured, cold-pressed, 160g/m² paper in a traditional white colour. Available in A5, A5L, A4, 8"x8" sizes with 64 sheets inside, these sketchbooks are ideal for sketches and mixed-media drawing with graphite/colour pencils, pen, marker, soft, oil pastels, gouache, acrylic paint. The papers in these journals are Italian-made, Acid-free, and FSC Certified. This journal is F.S.C certified as it comes from a well-managed forest that meets the highest environmental and social standards.



Artwork by Vanessa Ho @hoxihuei



Colour	A5	A5L
Black	SJ160A5-64BK	SJ160A5L-64BK
Grey	SJ160A5-64GY	SJ160A5L-64GY
Sand	SJ160A5-64SD	SJ160A5L-64SD
Cream	SJ160A5-64CM	SJ160A5L-64CM
Light Brown	SJ160A5-64LB	SJ160A5L-64LB
Toffee	SJ160A5-64TF	SJ160A5L-64TF
Yellow	SJ160A5-64YL	SJ160A5L-64YL
Lime	SJ160A5-64LM	SJ160A5L-64LM
Navy	SJ160A5-64NV	SJ160A5L-64NV
Red	SJ160A5-64RD	SJ160A5L-64RD
Barcode		

Colour	8" x8"	A4
Black	SJ16088-64BK	SJ160A4-64BK
Grey	SJ16088-64GY	SJ160A4-64GY
Sand	SJ16088-64SD	SJ160A4-64SD
Cream	SJ16088-64CM	SJ160A4-64CM
Light Brown	SJ16088-64LB	SJ160A4-64LB
Toffee	SJ16088-64TF	SJ160A4-64TF
Yellow	SJ16088-64YL	SJ160A4-64YL
Lime	SJ16088-64LM	SJ160A4-64LM
Navy	SJ16088-64NV	SJ160A4-64NV
Red	SJ16088-64RD	SJ160A4-64RD
Barcode		

DREAM© Cartrige Journal - 32 Sheets/120gsm

Dream© Cartrige Journal is made up of finely textured, cold-pressed, 120g/m² paper in a traditional white colour. Available in A5 Portrait Size with 32 sheets, the paper is in a traditional white colour. These sketchbooks are ideal for dry mediums as it is light and designed for daily journaling, writing, and sketching. The papers in these journals are Italian-made and Acid-free. These journals are available in 6 different cover colours. This journal is F.S.C certified as it comes from a well-managed forest that meets the highest environmental and social standards.

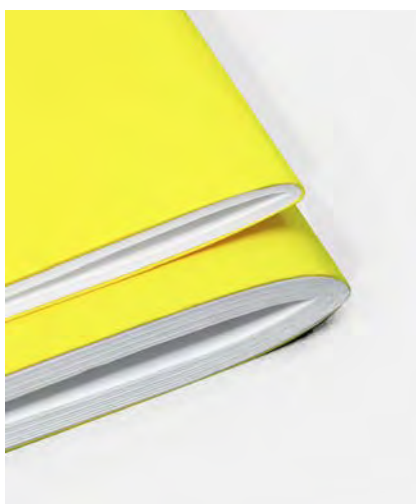

Colour	A5 (Cartridge)	Barcode
Black	CJ120-A532-BK	
Grey	CJ120-A532-GY	
Yellow	CJ120-A532-YL	
Green	CJ120-A532-GN	
Light Blue	CJ120-A532-LB	
Red	CJ120-A532-RD	

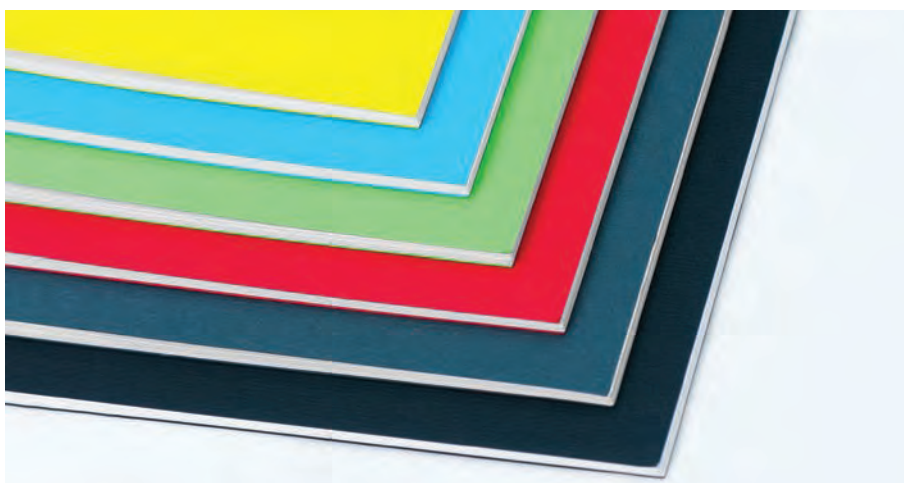



DREAM® Magic Cover Sketchbook

Dream® Magic Cover Sketchbook are made up of 40 sheets of A5 finely textured, cold-pressed paper made in Italy. These 120g/m² papers are in a traditional white colour with 28 cover colours to choose from. Each Magic Cover sketchbook has 5 covers (2 colours) and are interchangeable by flipping the covers over. It is also suitable for on-the-go and outdoor sketching due to its cardboard backing that gives an additional support for drawing. The papers are acid-free and FSC Certified as it comes from a well-managed forest that meets the highest environmental and social standards.

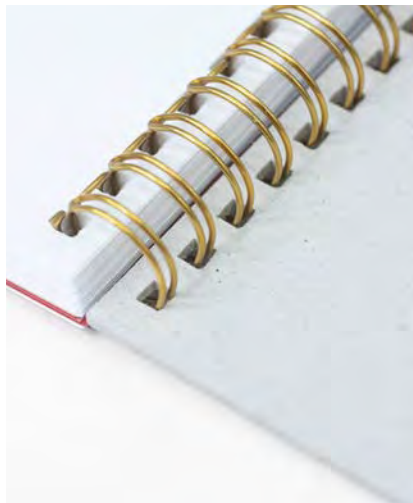

Colour	Code	Barcode
Berry Red	MCSI20A5-BR	8 888313 114389
Racy Raspberry	MCSI20A5-RR	8 888313 114346
Graceful Geranium	MCSI20A5-GG	8 888313 114353
Peaches & Cream	MCSI20A5-PC	8 888313 114360
Orange Dream	MCSI20A5-OD	8 888313 114377
Meri-Gold	MCSI20A5-MG	8 888313 114384
Sunshine Yellow	MCSI20A5-YY	8 888313 114391
Outdarsy Olive	MCSI20A5-OO	8 888313 114407
Spring Green	MCSI20A5-SG	8 888313 114414
Lucious Lime	MCSI20A5-LL	8 888313 114420
Emerald Isle	MCSI20A5-EI	8 888313 114438
Glorious Green	MCSI20A5-GG	8 888313 114353
Awesome Aqua	MCSI20A5-AA	8 888313 114452
Terrific Teal	MCSI20A5-TT	8 888313 114469
Hawaiian Blue	MCSI20A5-HB	8 888313 114476
Tempting Tazanite	MCSI20A5-TE	8 888313 114483
Belgium Blue	MCSI20A5-BB	8 888313 114490
Ocean Blue	MCSI20A5-OB	8 888313 114506
Groovy Grape	MCSI20A5-GG	8 888313 114353
Lovely Lilac	MCSI20A5-LL	8 888313 114520
Perfect Plum	MCSI20A5-PP	8 888313 114537
Totally Tan	MCSI20A5-TT	8 888313 114469
Coffee Brown	MCSI20A5-CB	8 888313 114551
Creamy Cocoa	MCSI20A5-CC	8 888313 114568
Chocolate Malt	MCSI20A5-CM	8 888313 114575
Desert Dune	MCSI20A5-DD	8 888313 114582
Morning Mist	MCSI20A5-MM	8 888313 114599

← Cover Colours →



DREAM© Sketch & Kraft Journal

Dream© Sketch & Kraft Journal comprise of 32 Sheets of Sketch Paper and 32 sheets of Kraft Paper. These 160g/m² papers are Acid-Free and made in Italy. These premium quality sketchbooks are ideal for drawing and mixed-media drawing with graphite/colour pencils, pen, marker, soft, oil pastels, gouache and acrylic paint. These A5 size journals are available in 6 different cover colours. The paper in this journal also FSC Certified as it comes from a well-managed forest that meets the highest environmental and social standards.

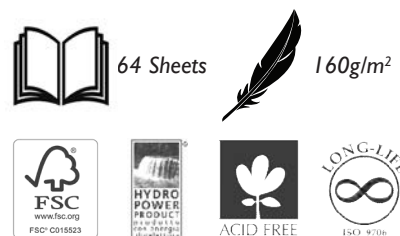

Colour	Code	A5 Size
Yellow	DR-SK64A5-YL	
Light Blue	DR-SK64A5-LB	
Green	DR-SK64A5-GN	
Red	DR-SK64A5-RD	
Navy	DR-SK64A5-NV	
Light Grey	DR-SK64A5-LG	
Grey	DR-SK64A5-GY	
Black	DR-SK64A5-BK	





KCK Colour Sketch Ring-Bind Sketchbook

KCK Ring-Bind Sketchbooks are made up of 80 sheets of coloured paper. With the standard black cover, there are 8 colours of papers to choose from. Suitable for daily journaling, sketching, drawing using mediums like graphite, colour pencils, charcoal, soft and oil pastels. KCK Ring Bind Sketchbook also features one extra colour, a Black Ring-Bind Sketchbook and consists of 40 sheets of black paper and a weight of 125g/m². These sketchbooks are only available in A5 size.



Colour	Code (80 Sheets)	Barcode (80g/m ²)
Orange	CS080A5-80OR	
Yellow	CS080A5-80YL	
Green	CS080A5-80GN	
Light Green	CS080A5-80LG	
Blue	CS080A5-80BL	
Lilac	CS080A5-80LL	
Pink	CS080A5-80PK	
Gold	CS080A5-80GL	
Colour	Code (40 Sheets)	Barcode (125g/m ²)
Black	BS125A5-40	





KCK Sketch Spiral Book

KCK Sketch Spiral Book is made up of 40 sheets of finely textured cold-pressed paper. Due to its cardboard backing, KCK Spiral Sketchbook gives additional support for outdoor or daily use of drawing & sketching. Available in traditional white colour, these 135gsm papers and are joined together with a piece of cardboard backing through a spiral-bound. An ideal surface for drawing, sketching with graphite/colour pencils, pen, marker, soft and oil pastels. Available in A5, A4, and A3 sizes.



Size	Code	Barcode
A5	SK340	
A4	SK440	
A3	SK540	





21 x 29.7cm



12 x 30cm

DREAM© Urban Sketch Gummed Pad

Dream© Urban Sketch Gummed Pad is made up of 30 sheets of 180g/m² finely textured, cold-pressed paper made in Italy. This Sketchbook is available in 4 different colours, and in A4 and 12x30cm size. These sketchbooks are ideal for sketches and mixed-media drawing with graphite/colour pencils, pen, marker, pastels, gouache, and acrylic paint. Suitable for on-the-go and outdoor drawings due to its cardboard backing that gives an additional support for drawing. The papers are acid-free and FSC Certified as it comes from a well-managed forest that meets the highest environmental and social standards.



Colour	12 X 30cm	Barcode
Pitch	USPI801230-30PT	
Kraft	USPI801230-30KR	
Limestone	USPI801230-30LS	
Clay	USPI801230-30CY	
Colour	A4	Barcode
Pitch	USPI80A4-30PT	
Kraft	USPI80A4-30KR	
Limestone	USPI80A4-30LS	
Clay	USPI80A4-30CY	

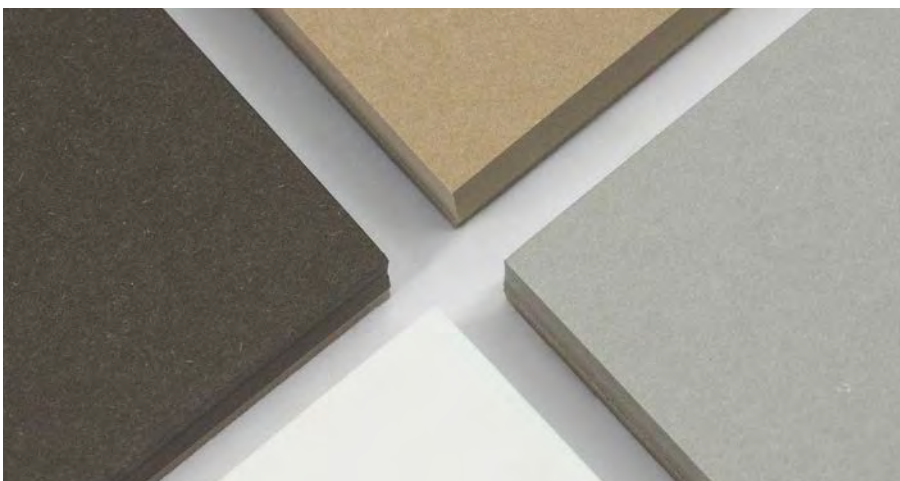



DREAM© Graphite Pencil Paper - Loose Sheets

Dream© Graphite Pencil Paper has a fine to medium texture which is suitable for pencil, graphite, charcoal, pastels, tempera and gouache. Ideal for fine art students for beginners, it is a great surface to experiment with a variety of media. Available in A4, A3, and A2 sizes. Made from 100% E.C.F pulp (Elemental Chlorine Free), this paper is F.S.C certified from a well-managed forest that meets the highest environmental and social standards. Recommended to be used with KCK Artist Grade Graphite Pencil.



Order Code	Size	Barcode
GCL160A4-10	A4	
GCL160A3-10	A3	
GCL160A2-10	A2	







20 Sheets

160 gm²

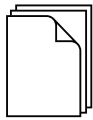

cold-pressed
(fine grain
texture)

DREAM© Pastel Paper - White

Dream© Pastel Paper is made from premium quality paper with a fine to medium texture. Made with 25% Cotton Fiber and lignin free, this paper is suitable for pastels, pencil, graphite, and charcoal. Contains 20 sheets of white paper.

Order Code	Size	Barcode
PP160A6-20WT	A6	
PP160A5-20WT	A5	
PP160A4-20WT	A4	
PP160A3-20WT	A3	



20 Sheets

160 gm²

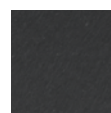
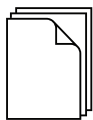

cold-pressed
(fine grain
texture)

DREAM© Pastel Paper - Black

Dream© Pastel Paper is made from premium quality paper with a fine to medium texture. Made with 25% Cotton Fiber and lignin free, this paper is suitable for pastels, pencil, graphite, and charcoal. Contains 20 sheets of black paper.

Order Code	Size	Barcode
PP160A6-20BK	A6	
PP160A5-20BK	A5	
PP160A4-20BK	A4	
PP160A3-20BK	A3	



20 Sheets

160g/m²



cold-pressed
(fine grain
texture)

DREAM© Pastel Paper - Assorted Colours

Dream© Pastel Paper is made from premium quality paper with a fine to medium texture. Made with 25% Cotton Fiber and lignin free, this paper is suitable for pastels, pencil, graphite, and charcoal. Contains 20 sheets of 18 Colours.

Order Code	Size	Barcode
PP160A6-20	A6	
PP160A5-20	A5	
PP160A4-20	A4	
PP160A3-20	A3	







22 Sheets

170 gm²



DREAM© Premium Construction Paper - Intense

Dream© Premium Construction Paper is made from premium quality construction paper with a fine texture. Suitable for laser-jet and inkjet printing such as printing graphics/ illustrations on zines, collages, craft and mixed media projects. Made with 25% Cotton Fiber and lignin free. This 170gsm paper is also ideal for sketching and drawing mixed media artworks with graphite/ colour pencil, pastels, gouache and acrylic paint. Contains 22 sheets with 11 bright colours inside.

Order Code	Size	Barcode
PCP170A4-22IN	A4	



22 Sheets

170 gm²

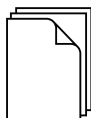

DREAM© Premium Construction Paper - Pastel

Dream© Premium Construction Paper is made from premium quality construction paper with a fine texture. Suitable for laser-jet and inkjet printing such as printing graphics/ illustrations on zines, collages, craft and mixed media projects. Made with 25% Cotton Fiber and lignin free. This 170gsm paper is also ideal for sketching and drawing mixed media artworks with graphite/ colour pencil, pastels, gouache and acrylic paint. Contains 22 sheets with 11 pastel colours inside.

Order Code	Size	Barcode
PCP170A4-22PA	A4	



22 Sheets

170g/m²



DREAM© Premium Construction Paper - Black & White

Dream© Premium Construction Paper is made from premium quality construction paper with a fine texture. Suitable for laser-jet and inkjet printing such as printing graphics/ illustrations on zines, collages, craft and mixed media projects. Made with 25% Cotton Fiber and lignin free. This 170gsm paper is also ideal for sketching and drawing mixed media artworks with graphite/ colour pencil, pastels, gouache and acrylic paint. Contains 11 sheets of black and 11 sheets of white paper.

Order Code	Size	Barcode
PCP170A4-22BW	A4	



40 Sheets

80 g/m²

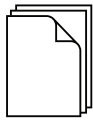

DREAM© Premium Construction Paper - Intense

Dream© Premium Construction Paper is made from premium quality construction paper with a fine texture. Suitable for laser-jet and inkjet printing such as printing graphics/ illustrations on zines, collages, craft and mixed media projects. Made with 25% Cotton Fiber and lignin free. This 170gsm paper is also ideal for sketching and drawing mixed media artworks with graphite/ colour pencil, pastels, gouache and acrylic paint. Contains 22 sheets with 11 bright colours inside.

Order Code	Size	Barcode
PCPI70A4-22IN	A4	 8 888313 115527



40 Sheets

80 g/m²

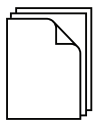

DREAM© Premium Construction Paper - Pastel

Dream© Premium Construction Paper is made from premium quality construction paper with a fine texture. Suitable for laser-jet and inkjet printing such as printing graphics/ illustrations on zines, collages, craft and mixed media projects. Made with 25% Cotton Fiber and lignin free. This 170gsm paper is also ideal for sketching and drawing mixed media artworks with graphite/ colour pencil, pastels, gouache and acrylic paint. Contains 22 sheets with 11 pastel colours inside.

Order Code	Size	Barcode
PCPI70A4-22PA	A4	 8 888313 115534



22 Sheets

170g/m²



DREAM© Premium Construction Paper - Black & White

Dream© Premium Construction Paper is made from premium quality construction paper with a fine texture. Suitable for laser-jet and inkjet printing such as printing graphics/ illustrations on zines, collages, craft and mixed media projects. Made with 25% Cotton Fiber and lignin free. This 170gsm paper is also ideal for sketching and drawing mixed media artworks with graphite/ colour pencil, pastels, gouache and acrylic paint. Contains 11 sheets of black and 11 sheets of white paper.

Order Code	Size	Barcode
PCPI70A4-22BW	A4	 8 888313 115510



40 Sheets

160 gm²

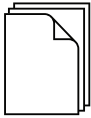

DREAM© Premium Construction Paper - Intense

Dream© Premium Construction Paper is made from premium quality construction paper with a fine texture. Suitable for laser-jet and inkjet printing such as printing graphics/ illustrations on zines, collages, craft and mixed media projects. Made with 25% Cotton Fiber and lignin free. This 170gsm paper is also ideal for sketching and drawing mixed media artworks with graphite/ colour pencil, pastels, gouache and acrylic paint. Contains 22 sheets with 11 bright colours inside.

Order Code	Size	Barcode
PCP170A4-22IN	A4	 8 888313 115527

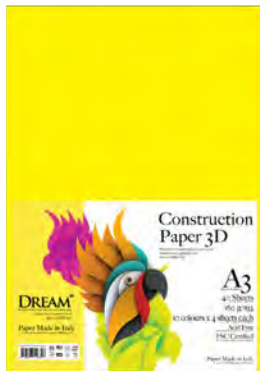

40 Sheets

160 gm²

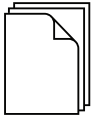

DREAM© Premium Construction Paper - Pastel

Dream© Premium Construction Paper is made from premium quality construction paper with a fine texture. Suitable for laser-jet and inkjet printing such as printing graphics/ illustrations on zines, collages, craft and mixed media projects. Made with 25% Cotton Fiber and lignin free. This 170gsm paper is also ideal for sketching and drawing mixed media artworks with graphite/ colour pencil, pastels, gouache and acrylic paint. Contains 22 sheets with 11 pastel colours inside.

Order Code	Size	Barcode
PCP170A4-22PA	A4	 8 888313 115534



22 Sheets

170g/m²



DREAM© Premium Construction Paper - Black & White

Dream© Premium Construction Paper is made from premium quality construction paper with a fine texture. Suitable for laser-jet and inkjet printing such as printing graphics/ illustrations on zines, collages, craft and mixed media projects. Made with 25% Cotton Fiber and lignin free. This 170gsm paper is also ideal for sketching and drawing mixed media artworks with graphite/ colour pencil, pastels, gouache and acrylic paint. Contains 11 sheets of black and 11 sheets of white paper.

Order Code	Size	Barcode
PCP170A4-22BW	A4	 8 888313 115510



Recycled Kraft Paper

A4
(210mm x 297mm)

125gsm
50 sheets

PP KR125A4-50



Paper

A4
(210mm x 297mm)

100gsm
50 sheets

PP KR100A4-50





KCK Recycled Kraft Paper

KCK Recycled Kraft Paper is made from post-consumer waste and turned into recycled paper. These environmentally friendly papers are suitable for sketching and drawing using pencil, graphite, charcoal, soft/oil pastels and crafting projects. This paper comes in two weights; 100 & 125 gsm. Each pack contains 50 sheets of brown kraft paper in A4 size.



Order Code	A4 Size	Barcode
KR100A4-50	100 g/m ²	
KR125A4-50	125 g/m ²	





TRACING PAPER

90GSM | 30 SHEETS | ACID FREE



KCK Tracing Paper

KCK Tracing Paper is made up of acid-free papers with a weight of 90gsm. This tracing paper has excellent transparency and paper toughness. Suitable for transferring artworks and designs into another piece of paper by using a graphite pencil. Great for practising developmental works for everyday use due to its weight and economical pack. Contains 30 sheets of tracing paper in A4 size.



Size	Order Code	Barcode
A4	TP90A4-30	





KCK Wooden Cork Sheet

KCK Wooden Cork Sheet is made up of cork oak, a material that is safe to use and environmentally friendly as it is renewable, biodegradable and naturally antibacterial. This Table Mat is lightweight and has a good grip suitable for any art and crafts project, this cork table mat protects the table top surface from any stain or scratches that happen during a project.

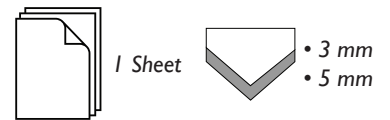

3mm	Order Code	Barcode
A4	WD CSA4-03	
A3	WD CSA3-03	
5mm	Order Code	Barcode
A4	WD CSA4-05	
A3	WD CSA3-05	

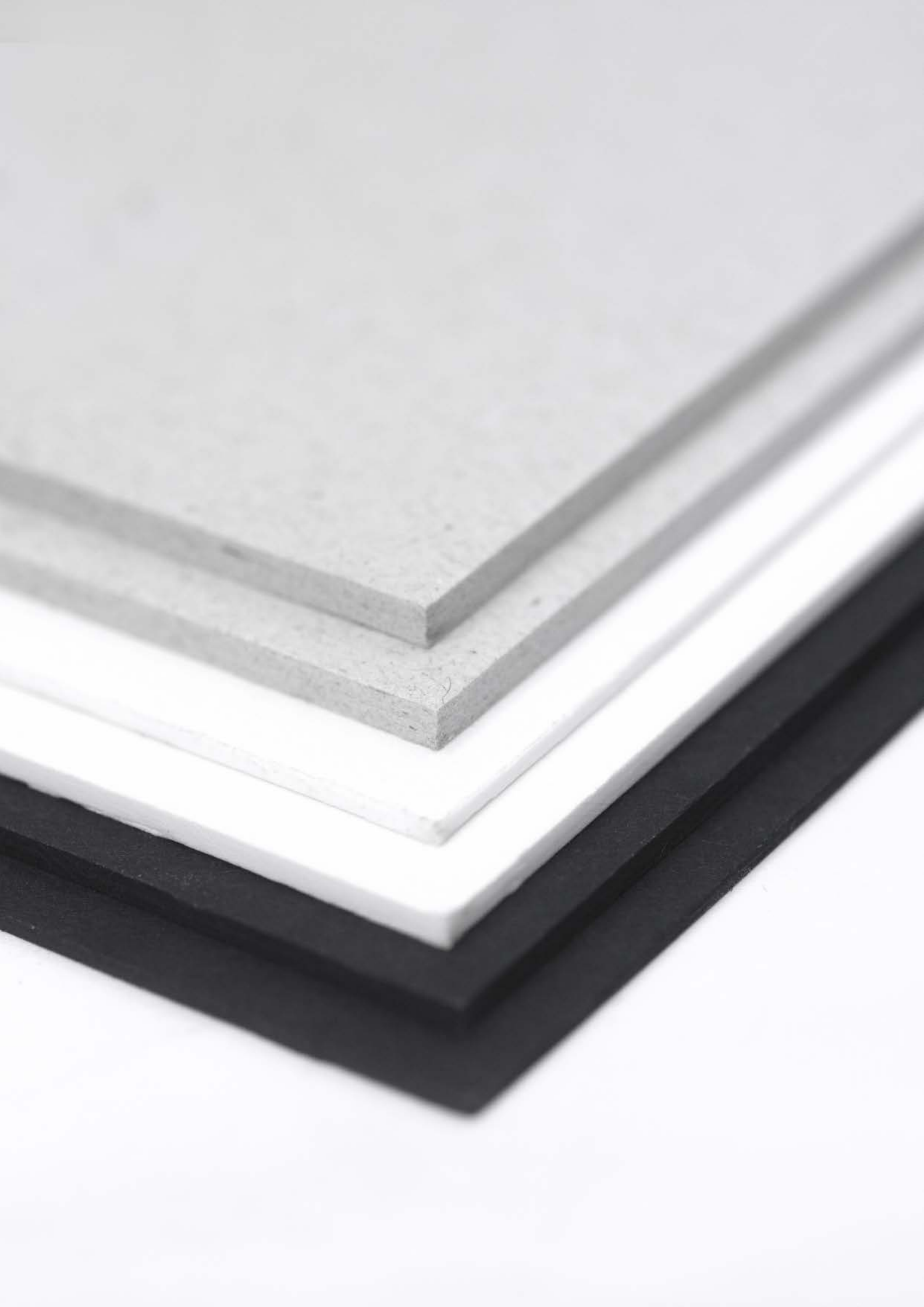

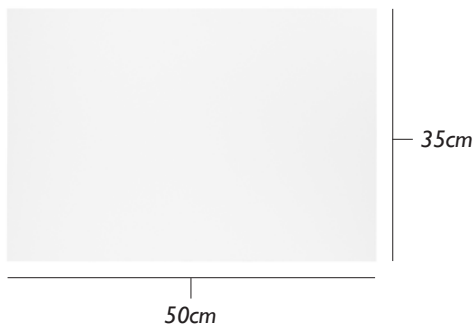

Thickness

- 1mm
- 1.5mm



Mounting Board - White

Made up of recycled paper, this white mounting board comes in 1 and 1.5mm thickness. Suitable for providing a rigid and sturdy surface or a more profound border after a finished artwork/ photograph. Only available in B3 size.

Order Code	B3 Size	Barcode
MB3550-10WT	1mm	
MB3550-15WT	1.5mm	

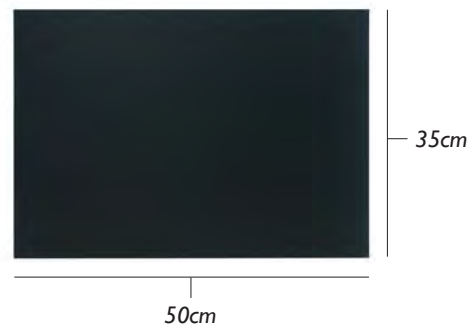
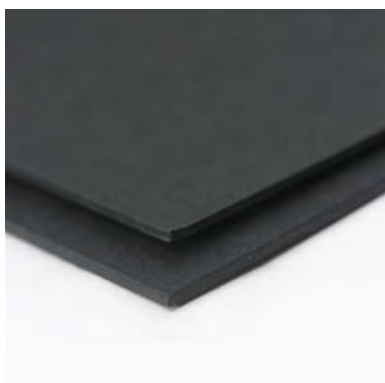

Thickness

- 1mm
- 1.5mm



Mounting Board - Black

Made up of recycled paper, this black mounting board comes in 1 and 1.5mm thickness. Suitable for providing a rigid and sturdy surface or a more profound border after a finished artwork/ photograph. Only available in B3 size.

Order Code	B3 Size	Barcode
MB3550-10BK	1mm	
MB3550-15BK	1.5mm	

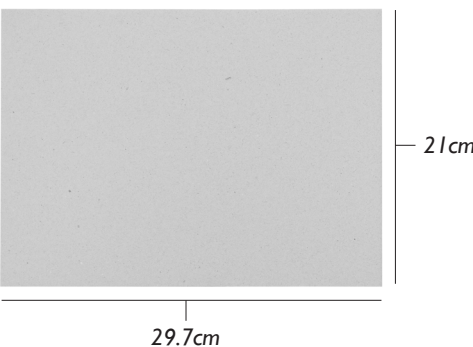
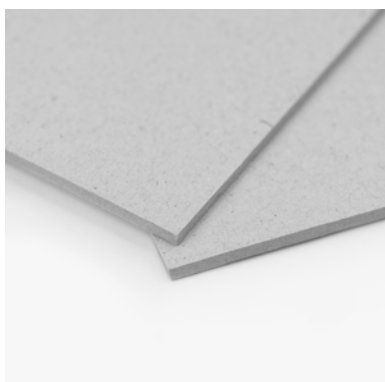



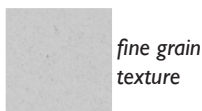

Thickness

- 2.4mm



Grey Board

Made up of recycled paper, this grey mounting board comes only in 2.4mm thickness. Suitable for providing a rigid and sturdy surface or a more profound border after a finished artwork/ photograph. This grey mounting board comes in 4 sizes, A4, A3, A2 and 25 x 37inch.

Order Code	Size	Barcode
GB024-A4	A4	
GB024-A3	A3	
GB024-A2	A2	
GB024-2537	25" x 37"	

KCK Black Card

KCK Black Card is made from post-consumer waste that turned into recycled paper. This environmentally friendly, black cards comes in 4 weights, 200,250,300 and 350gsm to choose from. Suitable for providing a rigid and sturdy surface with a profound border after a finished artwork/ photograph. Each pack contains 20 sheets of black card in A4 size.

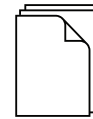

20 Sheets



- 200 g/m²
- 250 g/m²
- 300 g/m²
- 350 g/m²



Order Code	A4 Size	Barcode
BK200A4-20	200 g/m ²	
BK250A4-20	250 g/m ²	
BK300A4-20	300 g/m ²	
BK350A4-20	350 g/m ²	



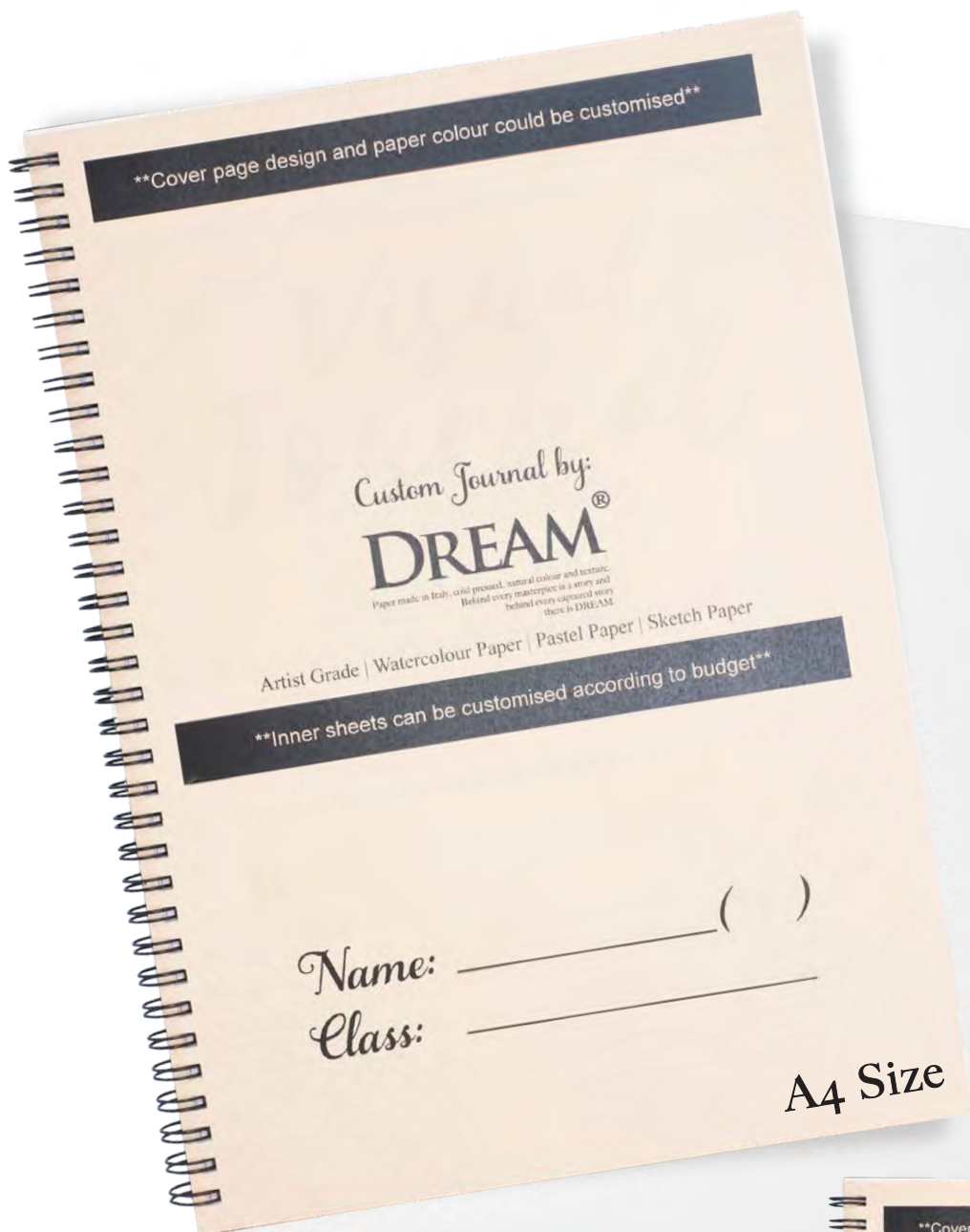

Dream® Customised Art Journal is designed for better learning in an organised and concised manner.

Papers are safely secured in a spiral-bound book and allow books to lay flat even when it becomes thick. The Plastic Front Cover allows for extra durability and protection. Cardboard Backing is suitable for on-the-go and outdoor drawing as there is an added stability at the back. Dream® Customised Art Journal Covers can be customised with your personalised logo while incorporating lesson plans/teaching materials printed on the papers of your choice.

Making it easier to keep track of the progress of every student as their artworks are all organised in one sketchbook.

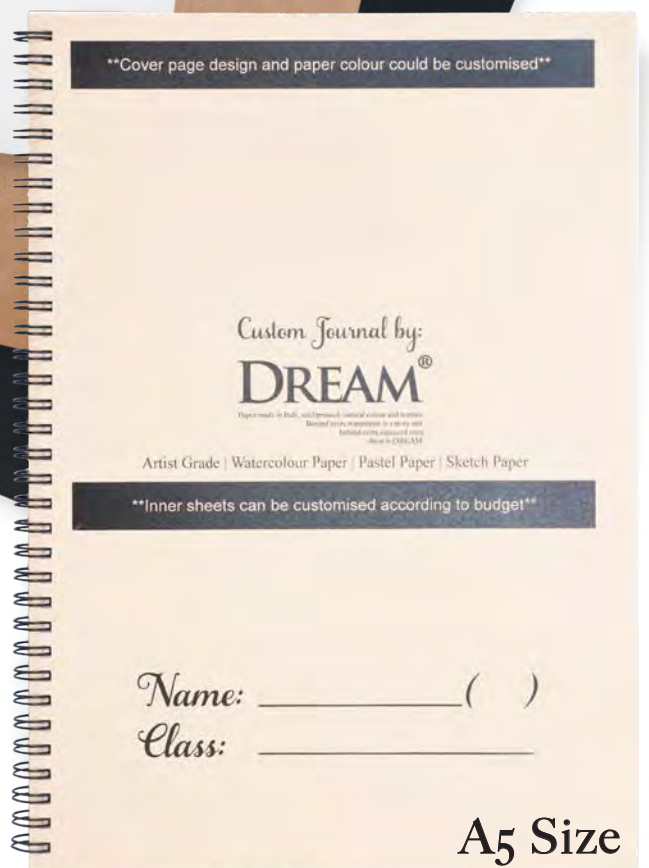

Dream® Customised Art Journal

DREAM®

Choose from
available papers



Customise with your
logo and lesson plans

Paper made in Italy.

F.S.C Certified, Made from well-
managed forests that meets the highest
environmental and social standards.

Types of Paper Available:



Pastel Paper



Black Paper



Drawing Paper



Graphite Paper



Kraft Paper



Watercolour Paper





Dream Academic Ring Bound Sketch Pad

KCK Ring-Bind Sketchbooks are made up of 80 sheets of coloured paper. With the standard black cover, there are 8 colours of papers to choose from. Suitable for daily journaling, sketching, drawing using mediums like graphite, colour pencils, charcoal, soft and oil pastels. KCK Ring Bind Sketchbook also features one extra colour, a Black Ring-Bind Sketchbook and consists of 40 sheets of black paper and a weight of 125g/m². These sketchbooks are only available in A5 size.



Colour	Code	A4 Size
Light Blue	PP ASI 20-20BL	
Green	PP ASI 20-20GN	
White	PP ASI 20-20WT	
Purple	PP ASI 20-20PU	
Orange	PP ASI 20-20OR	
Pink	PP ASI 20-20PK	





Book 4 - Paper & Pads



PLEASE RECYCLE

www.kck.sg

CRAFT & STATIONARIES



The Introduction

Choong Marketing was established in 1998 by Mr. K C Kang is an importer/exporter and distributor for stationery and art-based materials in Singapore. Since then, it is our company's mission to supply our customers with quality products. Over the years we have grown at a steady pace; increasing in the product range, brand representation, and channels to customers. As we continue to grow, we will continue to strengthen our position by working with partners with shared values and not forgetting our mission of providing ordinary products with extraordinary quality.

The Brands

If people are the company's right hand, the brands and partners would surely be its left hand. We value every brand we represent and it's our preference to work with brands that complement each other so that we would be able to grow in strength together. The following are brands that we represent exclusively:

•AMOS •CARIOCA •DREAM
•KANGARO •KCK QUALITY •KCK CRAFT
•KEBA KUM •MAIMERI •MARVY/UCHIDA
•MONTANA CANS •PLAY •SADIPAL

Contents

Pg 4 - 11	Crepe Papers, Craft Papers & Corrugated Papers
Pg 12-15	Eva Foam & Foam Die Cuts
Pg 16-19	Craft Accessories
Pg 20-21	Foam Rollers, Sponges and Stamps
Pg 22-23	Glue
Pg 24-27	Scissors & Knife Cutters
Pg 28-29	Rulers
Pg 30-31	Cutting Mats
Pg 32-33	KCK Pencils & KUM Pencil Grips
Pg 34-35	KCK Erasers & KUM Erasers
Pg 36-43	KUM Sharpeners
Pg 44-45	Bags
Pg 46-47	Styrofoam Boards & Shapes

**EXTRA TEXTURED,
SUPER STRETCHABLE.**



*See it in
action!*

CP617-23

KCK Ultra Crepe paper
Give some texture to your craft
projects KCK Ultra Crepe Paper

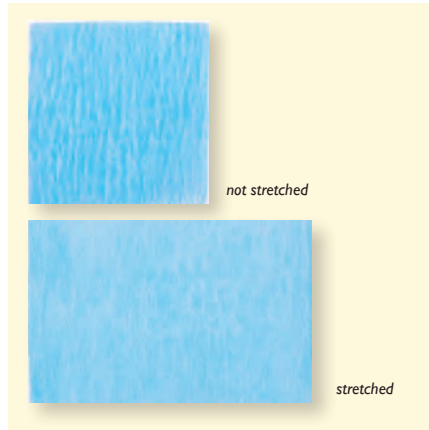

KCK Ultra Crepe Paper

Be amazed at the stretchability of this ultra crepe paper as you add this to your art & craft supplies. KCK Ultra Crepe Paper is specially made for crafting projects and decorations for special occasions. With great stretchability that stretches up to 1.5times its size, this Ultra Crepe Paper comes in 24 vibrant colours to choose from. KCK's Ultra Crepe Paper approximately measures 59.6 x 22.86cm and has excellent lightfastness due to its resistance in colour fading when exposed to light. This paper can be recycled and repurposed after being used as decorations and turn into shredded paper to provide support or cushion in parcels or gifts.



Stretchable



Excellent Lightfastness



CP617-47
Red



CP617-15
Orange



CP617-18
Dark Yellow

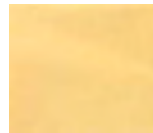

CP617-704
Peach



CP617-30
Yellow



CP617-701
Cream



CP617-12
Lime



CP617-710
Olive



CP617-41
Green



CP617-13
Dark Green



CP617-39
Blue



CP617-09
Turquoise



CP617-23
Light Blue



CP617-709
Lilac



CP617-21
Light Purple



CP617-06
Hot Pink



CP617-05
Fuchsia

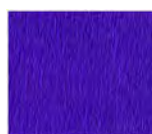

CP617-25
Dark Purple



CP617-43
Brown



CP617-28
Dark Brown



CP617-19
Black

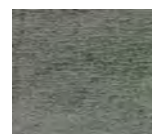

CP617-703
Grey



CP617-702
Light Grey



CP617-20
White







stretchable



excellent lightfastness



KCK Special Crepe Paper - Fluorescent

KCK Special Crepe Paper - Fluorescent is specially made for crafting and decorations. With great stretchability, the special Crepe Paper comes in 5 fluorescent colours and measures 50 x 200cm. This crepe paper has excellent lightfastness and is resistant to colour fading when exposed to light which is perfect for any crafting project.

Colour	Order Code	Barcode
F. Red	CP217-90	
F. Orange	CP217-91	
F. Yellow	CP217-92	
F. Green	CP217-93	
F. Pink	CP217-94	



stretchable



excellent lightfastness



KCK Special Crepe Paper - Pearlescent

KCK Special Crepe Paper - Pearlescent is specially made for crafting and decorations. With great stretchability, the special Crepe Paper comes in 4 pearlescent colours and measures 50 x 200cm. This crepe paper has excellent lightfastness and is resistant to colour fading when exposed to light which is perfect for any crafting project.

Colour	Order Code	Barcode
P. White	CP217-101	
P. Green	CP217-102	
P. Yellow	CP217-103	
P. Pink	CP217-104	
P. Purple	CP217-105	



stretchable



excellent lightfastness



KCK Special Crepe Paper - Metallic

KCK Special Crepe Paper - Metallic is specially made for crafting and decorations. With great stretchability, the special Crepe Paper comes in 3 metallic colours and measures 50 x 200cm. This crepe paper has excellent lightfastness and is resistant to colour fading when exposed to light which is perfect for any crafting project.

Colour	Order Code	Barcode
Silver	CP217-36	
Gold	CP217-38	

NARA CRAFT PAPERS



NR AEF00020

Nara Craft Paper
26cm x 26cm
12 assorted colours
Dinosaurs

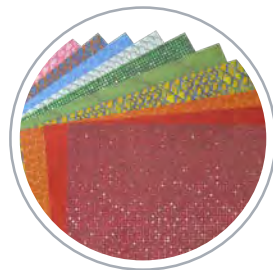
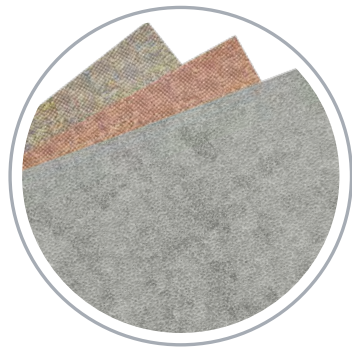

NR AEH00159

Nara Craft Paper
15cm x 15cm
20 sheets
Graphic I

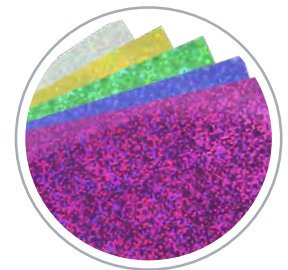

NR AEP00021

Nara Craft Paper
15cm x 15cm
5 sheets
Hologram



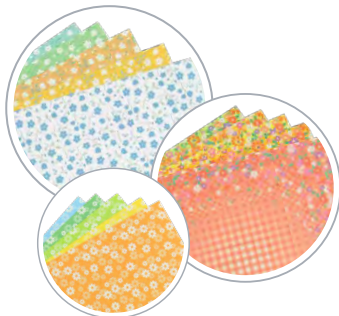

NR AEH00040
Nara Craft Paper
15cm x 15cm
40 sheets
Pattern 1

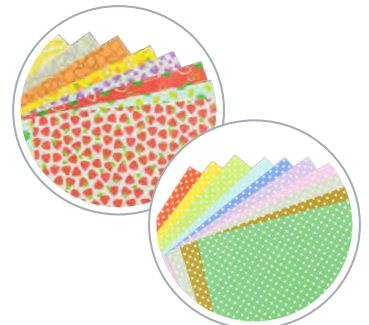

NR AEH00041
Nara Craft Paper
15cm x 15cm
40 sheets
Pattern 2

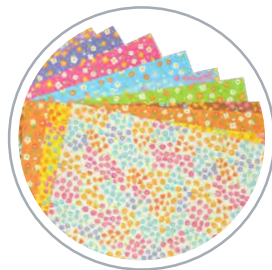

NR AEH00142
Nara Craft Paper
15cm x 15cm
20 sheets
Floral 1



NR AEH00027
Nara Craft Paper
15cm x 15cm -
20 sheets
Floral 2

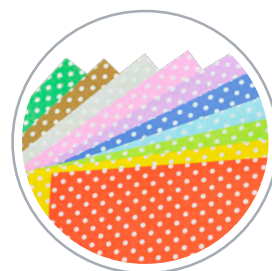

NR AEH00144
Nara Craft Paper
15cm x 15cm
20 sheets
Dotted 1

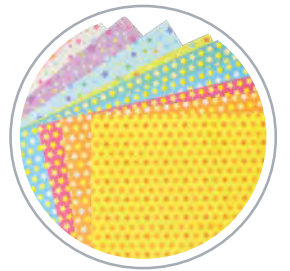

NR AEH00147
Nara Craft Paper
15cm x 15cm
20 sheets
Star 2



EXTRA TEXTURED, BRILLIANT COLOURS.



Non-toxic
Safe for Children



See it in
action!

HC CGI04-F

A4 Fluorescent Corrugated Paper
Spice up your craft project with
some bright fluorescent paper.

KCK Corrugated Paper

Fluted paper that provides strength and cushioning for your craft project.

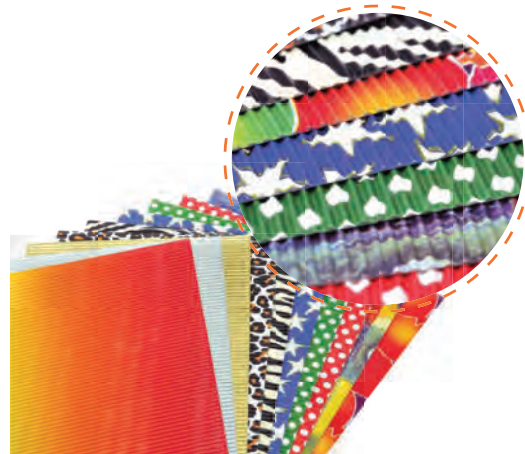

CE

HC CGI04-P
A4 Corrugated Paper
10 Assorted Design
10 Pieces
Printed

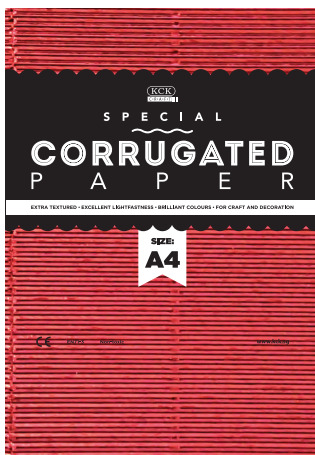

HC CGI04-M
A4 Corrugated Paper
10 Assorted Colours
10 Pieces
Metallic



HC CGI04-S
A4 Corrugated Paper
10 Assorted Colours
10 Pieces
Glittered



HC CGI04-C
A4 Corrugated Paper
10 Assorted Colours
10 Pieces
Classic Colour

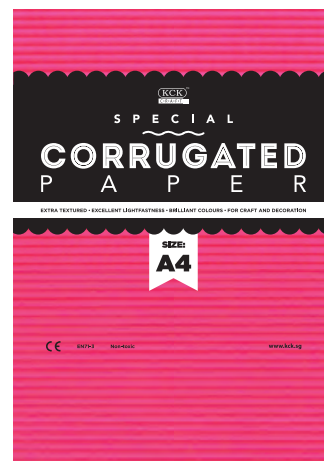

HC CGI04-F
A4 Corrugated Paper
10 Assorted Colours
10 Pieces
Fluorescent Colour



KCK Eva Foam

A4 Size

Code: F120

Packing

Qty / Pack : 12 pcs
 Qty / Inner : 10 packs
 Qty / Ctn : 30 packs

Description

KCK Eva Foam A4 12's
 12 colours asst pack.

Barcode



8 888313 073643



A3 Size

Code: F300

Description

KCK Eva Foam A3

Packing

Qty / Pack : 5 pcs
 Qty / Ctn : 20 packs



F300-04
Red



8 888313 104293



F300-20
Orange



8 888313 104392



F300-08
Peach



8 888313 104323



F300-32
Dark Yellow



8 888313 104339



F300-15
Neon Green



8 888313 104361



F300-33
Dark Green



8 888313 104446



F300-17
Kelly



8 888313 104385

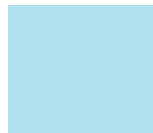

F300-07
Aqua



8 888313 104316



F300-14
Neon Blue



8 888313 104354



F300-05
Royal Blue



8 888313 104309



F300-09
Pink



8 888313 104330



F300-16
Neon Pink



8 888313 104378



F300-11
Purple



8 888313 104347



F300-29
Cocoa



8 888313 104415



F300-30
Dark Brown



8 888313 104422



F300-28
Dark Grey



8 888313 104408

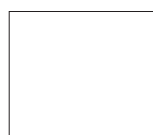

F300-01
White



8 888313 104279



F300-02
Black



8 888313 104286

A4 Size

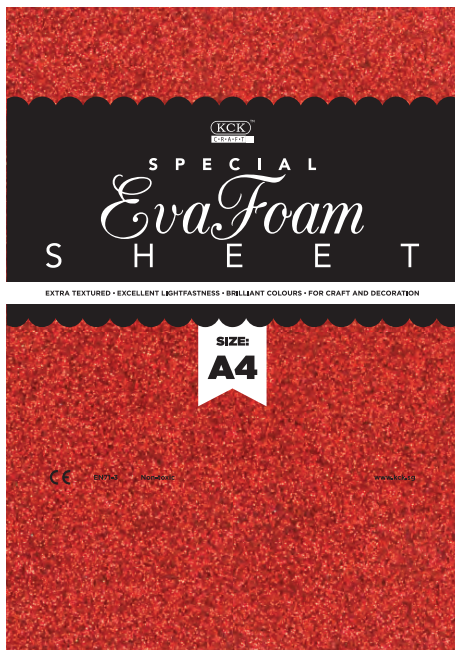

Code: EVA 104-G

Description
KCK Glitter Eva Foam A4 10's
10 colours asst pack.

Barcode



A4 Size

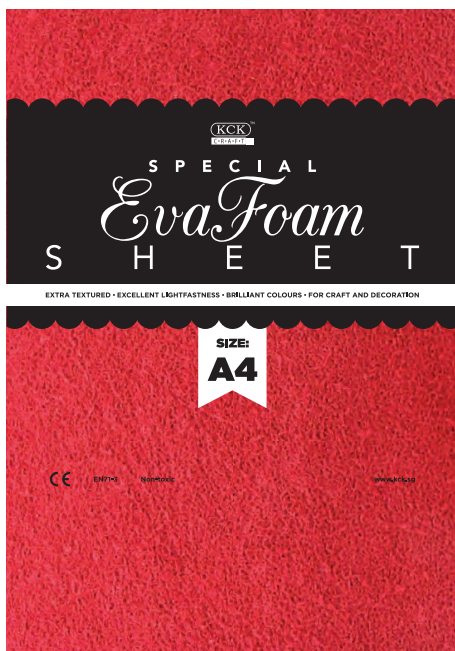

Code: EVA 104-P

Description
KCK Plush Eva Foam A4 10's
10 colours asst pack.

Barcode



KCK Eva Foam Die-Cuts



Non-toxic
Safe for Children

Die-Cut foams that 'cuts' half the time on preparing for a craft project.



HC FG54
Assorted Glitter Foam Die-Cuts
Flower



HC FG55
Assorted Glitter Foam Die-Cuts
Transports



HC FG56
Assorted Glitter Foam Die-Cuts
Ocean



HC FG53
Assorted Glitter Foam Die-Cuts
Stars



HC FG52
Assorted Glitter Foam Die-Cuts
Circles



HC FG51
Assorted Glitter Foam Die-Cuts
Assorted Shapes



HC FG57
Assorted Glitter Foam Die-Cuts
Alphabets



HC FG58
Assorted Glitter Foam Die-Cuts
Numbers



KCK
Multipurpose
PVA Glue

GL PVA

Great for binding EVA Foam



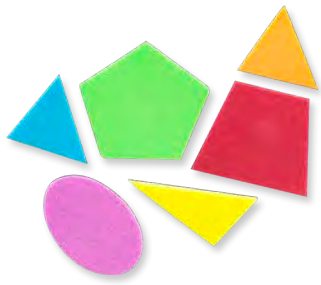

HC FS01
Assorted Foam Die-Cuts
Shapes



HC FS02
Assorted Foam Die-Cuts
Circles



HC FS03
Assorted Foam Die-Cuts
Stars



HC FS04
Assorted Foam Die-Cuts
Flowers



HC FS05
Assorted Foam Die-Cuts
Transports

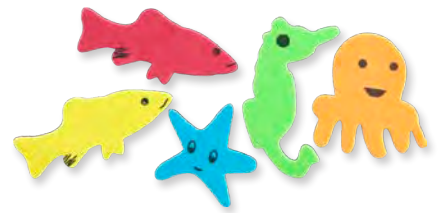

HC FS06
Assorted Foam Die-Cuts
Ocean



HC FS07
Assorted Foam Die-Cuts
Alphabets



HC FS08
Assorted Foam Die-Cuts
Numbers



KCK
Multipurpose
PVA Glue

GL PVA
Great for binding EVA Foam



HC BT02
Assorted Plastic Buttons
Flower Garden



HC BT03
Assorted Plastic Buttons
Starry Bear



HC BT01
Assorted Round Plastic
Buttons



KCK Wooden Craft Accessories

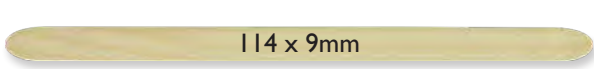

114 x 9mm

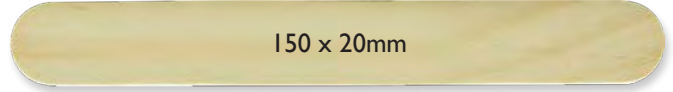

150 x 20mm



HC 115W
Wooden Craft Stick
114 x 9mm
100 pieces



HC 115C
Colour Craft Stick
114 x 9mm
100 pieces



HC 215W
Wooden Craft Stick
150 x 20mm
50 pieces



HC 215C
Colour Craft Stick
150 x 20mm
50 pieces

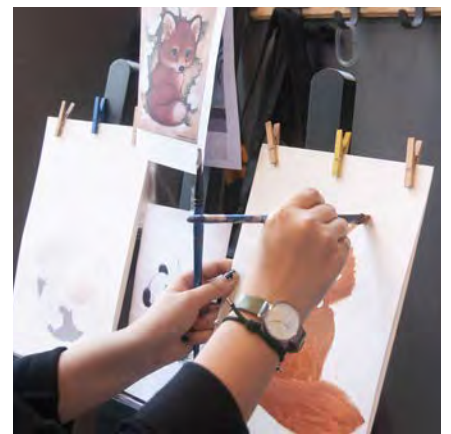

4mm x 26mm

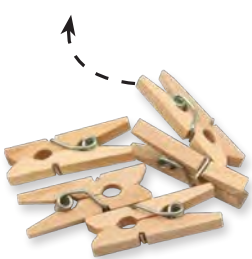

HC 224W
Mini Wooden Pegs 50's
Original
50 pieces



7mm x 35mm

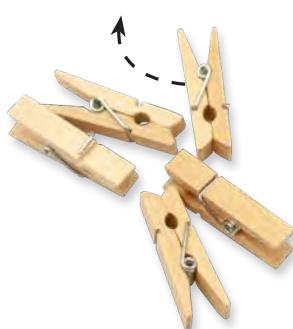

HC 324W
Mini Wooden Pegs 40's
Original
40 pieces

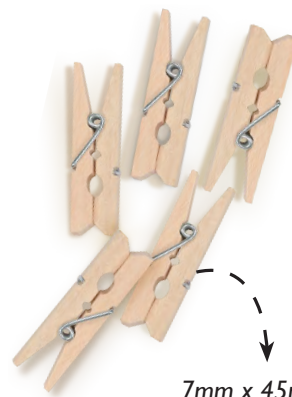

7mm x 45mm

HC 424W
Mini Wooden Pegs 40's
Original
40 pieces



7mm x 45mm

HC 424C
Mini Wooden Pegs 40's
Coloured
40 pieces



KCK Fluffy Craft Accessories



See it in
action!



HC FEA12-20

Craft Feathers

20 Pieces

12cm



HC FEA18-20

Craft Feathers

20 Pieces

18cm



KCK Fluffy Craft Accessories

KCK Craft Accessories are great for craft projects and a great tool for sensory learning. This pompoms can be made into bookmarks, indoor decorations and enhance upcycled clothes, bags by stitching them together. This pompom enhances the visual and touch sensory due to its vibrant colours and wool-like texture, great for sensory art.



PM15100M

Craft Pom Pom

100 Pieces

1.5cm



PM20050M

Craft Pom Pom

50 Pieces

2cm



PM25040M

Craft Pom Pom

40 Pieces

2.5cm



HC 6030-1

Craft Pipe Cleaner

60 pieces

Red Hue



HC 6030-2

Craft Pipe Cleaner

60 pieces

Green Hue



HC 6030-3

Craft Pipe Cleaner

60 pieces

Pink Hue



HC 6030-4

Craft Pipe Cleaner

60 pieces

Purple Hue



HC 1030M

Craft Pipe Cleaner

50 pieces

Metallic Colours



HC 12030M

Craft Pipe Cleaner

120 pieces

24 Colours







HC GE05150
Googly Eyes
5mm



HC GE10100
Googly Eyes
10mm



HC GE12080
Googly Eyes
12mm



HC GE15050
Googly Eyes
15mm



KCK Googly Eyes

These wiggle eyes are perfect for creating fun designs on puppets, dolls, birthday cards, photos, drawings, scrapbooking and kid's crafts projects, making your handicrafts more lively. Comes with self-adhesive that is easy to peel and stick. Use your wild imagination, stick these google eyes and let it come to life into wiggle eyes animate puppets, pet rocks, photos, drawings or scrapbooking.

Size	Pieces	Order Code	Barcode
5mm	80pcs	HC GE05080	
5mm	150pcs	HC GE05150	
5mm	400pcs	HC GE05400	
8mm	40pcs	HC GE08040	
8mm	200pcs	HC GE08200	
10mm	100pcs	HC GE10100	
12mm	30pcs	HC GE12030	
12mm	80pcs	HC GE12080	
12mm	150pcs	HC GE12150	
15mm	20pcs	HC GE15020	
15mm	50pcs	HC GE15050	
15mm	100pcs	HC GE15100	



See it in action!



Not safe for children under 5 years old

KCK Craft Foam Roller



HC TL738
Hobby Craft Paint Tray + Tools Set



HC TL758
Hobby Craft Foam Roller Set
6 Pieces
Blue



HC TL759
Hobby Craft Foam Roller Set
3 Pieces
Pink



HC TL760
Hobby Craft Foam Roller Set
4 Pieces
Blue



HC TL741
Hobby Craft Foam Roller Set
4 Pieces
Shapes



HC TL742
Hobby Craft Foam Roller Set
3 Pieces
SML Set



HC TL761
Hobby Craft Background Stamps
3 Pieces
'A' Set

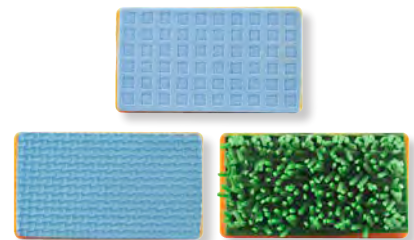

HC TL762
Hobby Craft Background Stamps
3 Pieces
'B' Set



HC TL763
Hobby Craft Pattern Block
3 Pieces
'A' Set

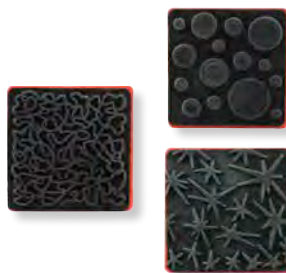

HC TL764
Hobby Craft Pattern Block
3 Pieces
'B' Set



HC TL740
Hobby Craft Stamps
4 Pieces
Flower



Sponge Brush & Stamps



HC TL747

Hobby Craft Foam Stamps
10 Pieces
Numbers Set



HC TL746

Hobby Craft Foam Stamps
4 Pieces
Human Set



HC TL745

Hobby Craft Foam Stamps
4 Pieces
Ocean Set

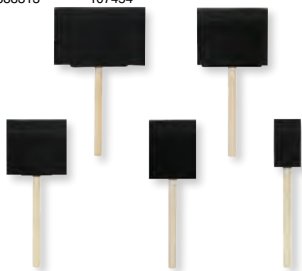

BRSPG05

Hobby Craft Sponge Brush
5 Pieces



HC TL748

Hobby Craft Foam Stamps
26 Pieces
Alphabets Set



HC TL743

Hobby Craft Foam Stamps
10 Pieces
Garden Set



HC TL744

Hobby Craft Foam Stamps
5 Pieces
Animals Set

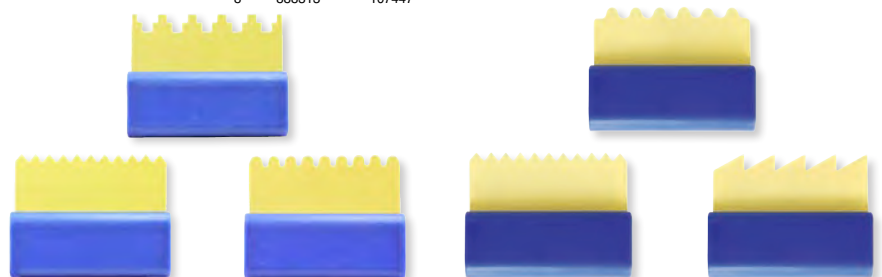

HC TL765

Hobby Craft Stucco Tools
Set A



HC TL739

Hobby Craft Stucco Tools
Set B



KCK Glue

A tool for every craft project.



See it in action!



GL K1000

KCK General Purpose Liquid Glue
1000ml

Excellent for most paper craft projects, collaging, and scrapbooking. This glue is safe for children as it is easily washable, non-toxic, and non-flammable. Due to its solvent-free characteristic, this general purpose glue is also environmentally friendly. This glue is available only in a bottle of 1000ml.



GL SG030

KCK All Purpose Silicone Glue
30ml

A strong, clear and flexible glue that attaches heavy-weight surfaces together. This all-purpose silicone glue is able to bond and dries quickly. This glue is suitable for bonding cork, cardboard, canvas, foam, fabric, ceramic, rubber, metal & plastics. Remember to close cap after use. This glue is available only in a small bottle of 30ml.



GL PVA

KCK PVA White Glue
40ml, 125ml, 250ml, 500ml & 1000ml

KCK Poly-Vinyl Acetate White Glue sticks paper, cardboard, foam sheets, wood, and light fabric. An excellent choice for craft projects as it dries clear. Easily washable with soapy water, this glue is environmentally friendly, non-toxic & safe for children.

Size	Order Code	Barcode
40ml	GL PVA0040	
125ml	GL PVA0125	
250ml	GL PVA0250	
500ml	GL PVA0500	
1000ml	GL PVA1000	



Acid-Free
Easy Cleanup



Non-toxic
Safe for Children



Dries Fast & Clear
Office & Home Use



GL 8G
KCK Glue Stick
8gram/0.28oz



8 888313 140130

GL 21G
KCK Glue Stick
21gram/0.74oz



8 888313 140161

GL K40
KCK Liquid Glue
40ml



8 888313 162897



GL GGTL186
Glue Gun
Small

Perfect for crafts projects that bind surfaces like fabric, woven material and rough surfaces like cardboard and wood. This glue gun has the highest setting of 40 watts and comes with a 2-pin cord attached. Suitable for kids above the age of 8.



9 835566 456135



GL GG10G-6
Glue Gun Refill
Glitter (3 colours)
6 pieces

Perfect for decorative art as it dries clear with glitter. These hot sticks give your craft projects a strong adhesion between the surfaces that are being bonded together. Compatible with Glue Gun 'Small'.



8 888313 114094



GL GG10T-6
Glue Gun Refill
Transparent
6 pieces

Perfect for most of your craft projects as it dries clear. These hot sticks give your craft projects a strong adhesion between the surfaces that are being bonded together. Compatible with Glue Gun 'Small'.



8 888313 114100

YOKEN Scissors



See it in action!



Child Safe
Flat Point



Child Safe
Round Tip



Child 8+ Safe
Round Tip



SC Y205F
YOKEN Round Tip Scissors
5 Inches



8 888313 601099



SC Y206
YOKEN Round Tip Scissors
6 Inches



8 888313 601105



SC K1061
YOKEN Scissors
6.5 Inches



Light
Weight

SC Y361
YOKEN Stainless Steel Scissors
with Refined Plastic Handle
6.5 Inches



8 888313 600863

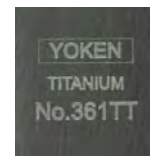

Light
Weight



Strong

SC Y361TT
YOKEN Titanium Scissors
with Refined Plastic Handle
6.5 Inches



8 888313 601112

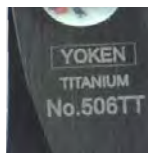

Strong

SC Y506TT
YOKEN Titanium Scissors
with Refined Plastic Handle
6.5 Inches



8 888313 601129



Light
Weight

SC Y303R
YOKEN Stainless Steel Scissors
with Refined Plastic Handle
8.5 Inches



8 888313 601129

KCK Craft Scissors



SCK608
KCK Craft Scissors Set
12 Assorted Designs
6 Inches



SCK607
KCK Craft Scissors Set
6 Assorted Designs
7 Inches



SC 711
Children Plastic Scissors
2 pieces



K804C
KCK Penknife
1 piece



K802C
KCK Penknife
1 piece



NEW & IMPROVED

For Handicraft & Cutting

For a comfortable cutting experience



Packaging



Black



Dark Grey



Silver

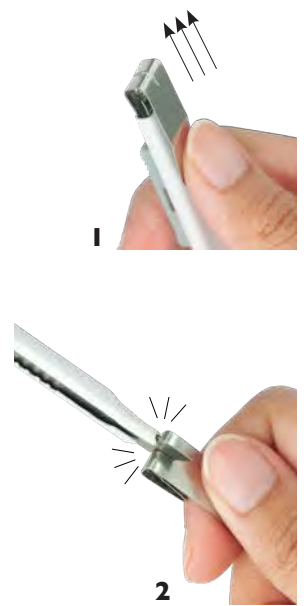

- Step 1.
1 Remove blade breaker
- Step 2.
2 Break blunt blade

K100
KCK Precision Cutter
Black/White/Grey



8 888313 601143



Measurement: 132x10x10mm

KCK Precision Knife Cutter

Use this knife cutter and you will be surprised with its compact, sleek design and the precise cutting experience it comes with. The textured slider pushes out and retracts easily while remaining stable when cutting across thin or thick paper. Simply snap away the blunt blades with the metal blade breaker, this knife cutter is suitable for on-the-go as the metal blade breaker is designed as a pocket clip as well. With the 60 degrees precision blade and the 0.45mm thickness, this knife cutter can easily open boxes, cuts through paper and sharpens pencils.



60° PRECISION



Not safe
for children



Strong



KCK Ruler

Essential measuring tool everyone needs.



RU K200
KCK Plastic Ruler
15cm/6 inch



DURABLE



Lightweight

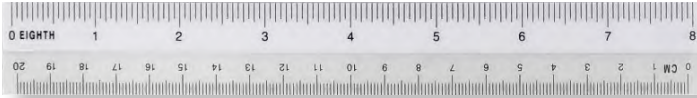

RU K300
KCK Plastic Ruler
20cm/8 inch



RU K400

KCK Plastic Ruler
30cm/12 inch



KCK Plastic Rulers are durable and flexible. One side has metric measurements with centimetres and the other side are in inches. KCK Plastic ruler is available in 30cm/12 inch size and 20cm/8inch size.

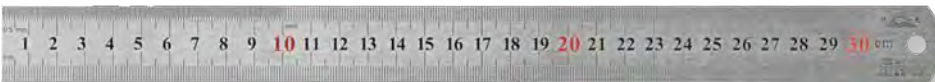

RU M30

KCK Stainless Steel Ruler
30cm/12 inch



Strong

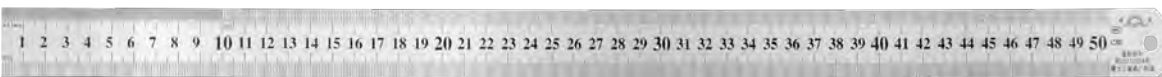

RU M50

KCK Stainless Steel Ruler
50cm/20 inch

KCK Stainless Steel Rulers are durable and malleable. This ruler is strong and rigid to work on more heavy-duty projects. This ruler also features a hole in the curved end so that it can be hung for easy storage. Perfect for a wide range of occupations and field of study including geometry, printing, technical drawing, building/ engineering and art projects.



DURABLE



Strong

RU W100

KCK Wooden Ruler
100cm/1 metre

KCK Wooden Ruler is durable and wear-resistant. Due to its rigidity, this wooden ruler is suitable for construction projects such as sewing, construction and craft projects. KCK Wooden Ruler is only available in 100cm/ 1meter.

UCHIDA Triangle Scale Rulers

Uchida Triangle Scale Ruler - 1 ruler : 3 sides : 6 different scales.

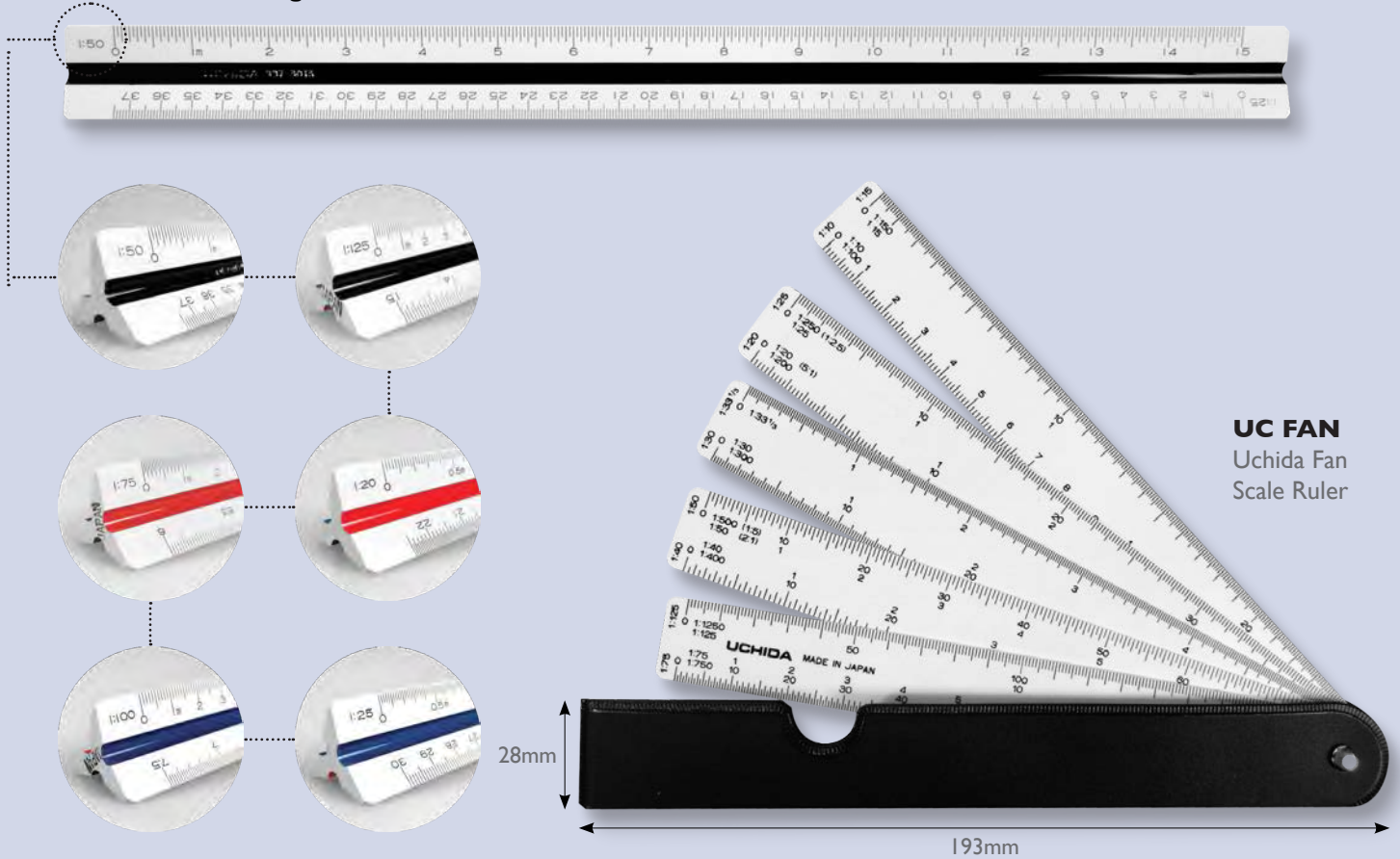

UC FAN
Uchida Fan
Scale Ruler

Order Code	Length	Scale	Barcode
UC 1211	12 inch	10 to 60 part in inch (Engineer)	
UC 1212	12 inch	1/8 to 3 inches (Architect)	
UC 3011	30 cm	1 : 100, 200, 300, 400, 500, 600	
UC 3012	30 cm	1 : 100, 200, 250, 300, 400, 500	
UC 3013	30 cm	1 : 20, 25, 50, 75, 100, 125	
UC 3014	30 cm	1 : 500, 1000, 1250, 1500, 2000, 2500	
UC 3015	30 cm	1 : 20, 25, 33-1/3, 50, 75, 100	
UC 3016	30 cm	1 : 2-1/2, 5, 10, 20, 50, 100	
UC 3051	30 cm	1 : 15, 20, 25, 33-1/3, 50, 100	
UC 3052	30 cm	1 : 10, 15, 20, 25, 50, 75	
UC 3053	30 cm	1 : 500, 625, 1000, 1250, 2000, 2500	
UC 3054	30 cm	1 : 500, 1000, 2000, 2500, 4000, 5000	
UC 3056	30 cm	1 : 75, 125, 150, 200, 250, 500	
UC 3060	30 cm	1 : 100, 150, 200, 250, 300, 350	
UC 3061	30 cm	1 : 25, 50, 75, 100, 125, 150	
UC 1511	15 cm	1 : 100, 200, 300, 400, 500, 600	
UC FAN	-	1 : 10, 15, 20, 25, 30, 33-1/3, 40, 50, 75, 125	

UCHIDA Fan Scale Ruler

Be amazed when you measure and scale with Uchida's Butterfly Fan Scale Ruler. Suitable for the on-the-go as this ruler is small and portable when kept in the synthetic leather case. Made up of flexible plastic, thick enough to ensure that it does not slip and move around when drawing. This compact ruler consists of 10 different scales.

UCHIDA Triangle Scale Rulers

Measure and scale using these durable, high impact plastic scale rulers. Each specialized ruler comes in 3 sides with 6 different scales. These scale rulers are designed for drafting, measuring architectural drawings, such as floor plans and orthographic projections. A must-have tool for architects, draftsmen, engineers, or students. Triangle Scale Rulers are available in 16 sizes.



DURABLE
UCHIDA

KCK Cutting Mats

Protection for your work surfaces makes a huge difference.

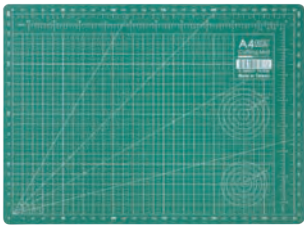

CM A4

KCK Cutting Mat
A4 Size

Safety comes first, even for your surfaces! KCK Cutting Mat protects your work surfaces from getting damaged and prevents leaving a rough and sharp surface when working on your next project. Suitable for sewing, quilting, craft projects like paper art collages and most cutting work.

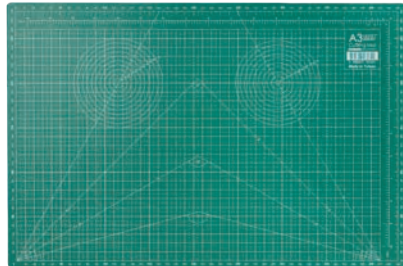

CM A3

KCK Cutting Mat
A3 Size

Safety comes first, even for your surfaces! KCK Cutting Mat protects your work surfaces from getting damaged and prevents leaving a rough and sharp surface when working on your next project. Suitable for sewing, quilting, craft projects like paper art collages and most cutting work.

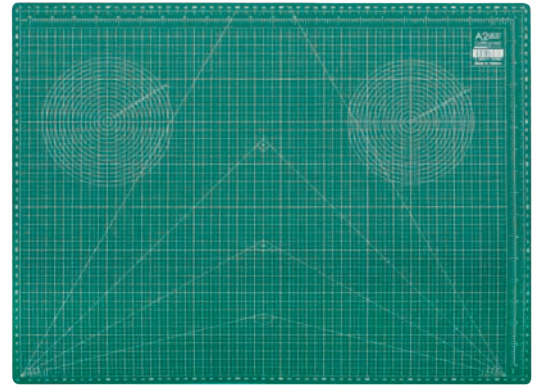

CM A2

KCK Cutting Mat
A2 Size

Safety comes first, even for your surfaces! KCK Cutting Mat protects your work surfaces from getting damaged and prevents leaving a rough and sharp surface when working on your next project. Suitable for sewing, quilting, craft projects like paper art collages and most cutting work.

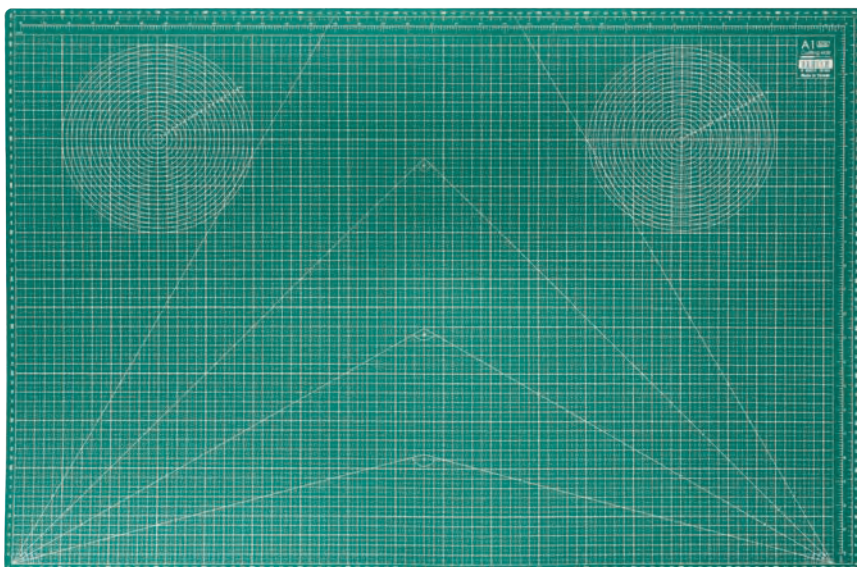

CM A1

KCK Cutting Mat
A1 Size

Safety comes first, even for your surfaces! KCK Cutting Mat protects your work surfaces from getting damaged and prevents leaving a rough and sharp surface when working on your next project. Suitable for sewing, quilting, craft projects like paper art collages and most cutting work.



A1 Size

NEW & IMPROVED Bye-bye scratches

Hello scratchproof, recyclable, self-healing mats.

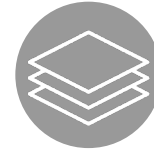
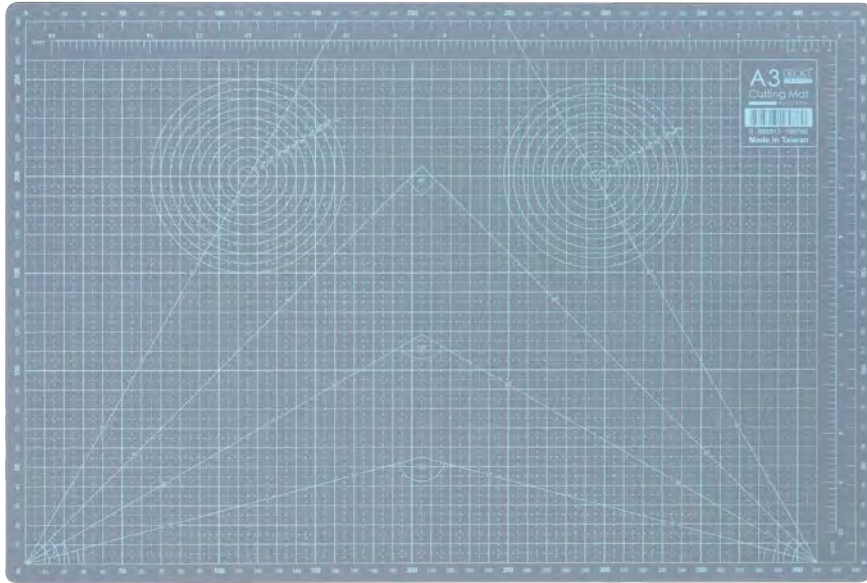

3 STURDY
VINYL LAYER



NON-SLIP
SCRATCH-PROOF

CM A3GY

KCK Grey Cutting Mat
45x30x0.3cm



8 888313 169780

CM A4GY

KCK Grey Cutting Mat
30x22x0.3cm

Our new & improved cutting mats protect your working table surface. Our cutting mats are strong enough to withstand craft tools, knives, rotary cutters, straight and sharp blades. Suitable for artists, crafters, builders, quilters, engravers as a DIY cutting board at your room, home, school or office, these cutting mats are great for collage art. Available in A4 & A3 sizes.



8 888313 169773

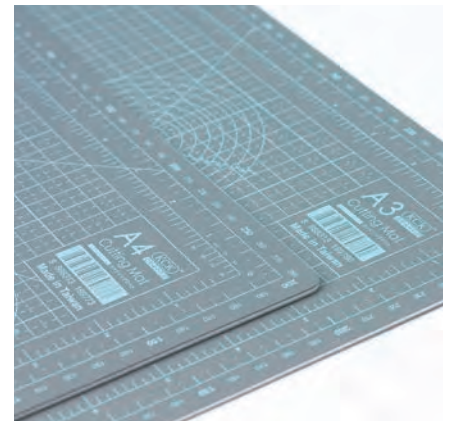

KCK GRAPHITE PENCILS NON-ROLL BREAK-RESISTANCE



PE 8100
Element Noir Pencils
Box of 12s
HB Grade



PE 8200
Element Noir Pencils
Box of 12s
2B Grade



PE 8300
Element Noir + Gomme Eraser Pencils
Box of 12s
HB Grade



PE 4647
Element Primo Eraser Pencils
Box of 12s
2B Grade



PE S400
KCK Smile Rainbow Weekly Pencils
Box of 14s
2B Grade



KCK Element Noir Pencils

A perfect tool for everyday writing. Non-roll and break-resistant, the pencils are manufactured with strict quality control to ensure the consistency of the lead. Suitable for everyday general writings and academic papers, KCK Element Noir Pencil 2B produces smooth, bold and clear lines. Featuring a hexagonal barrel, the pencils create minimal smudging and are easy to hold for a long period of time. Available in HB, 2B and 2B with an eraser attached. Sold in a box of 12.



KU SGRIP

KUM® Sattler Tri Pencil Grip



Small Size, with big results. How you grip your pencil and how your pencil feels in your hands can affect the attitude of everyday learning. This pencil grip is ergonomically designed for both the Right-Handed and Left-Handed without straining the fingers too much.

Right-Hander, place your thumb on the recess marked with "R".

Left-Hander, place your thumb on the recess marked with "L".

This pencil grip fits on most Pencils, Pens, and Brushes.



KU SGRIP

KUM® Sattler Pencil Grip



Small Size, with big results. How you grip your pencil and how your pencil feels in your hands can affect the attitude of everyday learning. This pencil grip is ergonomically designed for both the Right-Handed and Left-Handed.

Right-Hander, place your thumb on the recess marked with "R".

Left-Hander, place your thumb on the recess marked with "L".

This pencil grip fits on Pencils, Markers, Pens, Crafting Knives, Brushes etc.



KU 34070424

KUM® Cap Pencil Sharpener POP-D



Keep your pencil cases and school bag clean and tidy with KUM's Pencil Sharpener Cap. This cap sharpener is able to be clipped onto a shirt pocket, clipboard and are able to compile papers together. This sharpener prevents wedging and produces a sharp, clean pencil tip. Suitable for pencils with diameters up to 8mm.





ER K20 KCK Eraser - White
60mm x 22mm x 12mm



ER K48 KCK Eraser - White
44mm x 18mm x 12mm

Order Code	Article Number	Dimensions	Barcode No.
	ERK20	60mm x 22mm x 12mm	8 888313 800201
	ER K48	44mm x 18mm x 12mm	8 888313 165881

KCK Dust-Free Eraser White - S & L

KCK Dust-Free Eraser's residue and dust easily rolls together for easier clean up after erasing. This dust-free eraser creates lesser eraser debris as compared to a normal eraser by removing led pencils and graphites marks with ease. This eraser is suitable for architecture, design, and artworks as it erases and reduces clean and deep lines without damaging the paper surface. These erasers comes in two sizes small and large in the colour white.

MESS FREE

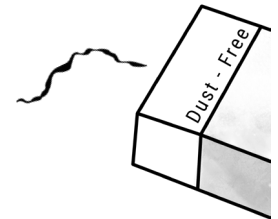

KCK Dust-Free Eraser Black - S & L

KCK Dust-Free Eraser's residue and dust easily rolls together for easier clean up after erasing. This dust-free eraser creates lesser eraser debris as compared to a normal eraser by removing led pencils and graphites marks with ease. This eraser is suitable for architecture, design, and artworks as it erases and reduces clean and deep lines without damaging the paper surface. These erasers comes in two sizes small and large in the colour black.

MESS FREE

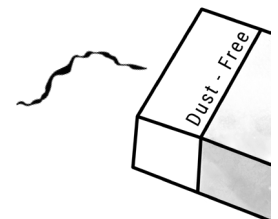

ER K20B KCK Eraser - Black
60mm x 22mm x 12mm



ER K48B KCK Eraser - Black
44mm x 18mm x 12mm

Order Code	Article Number	Dimensions	Barcode No.
	ERK20B	60mm x 22mm x 12mm	8 888313 165904
	ER K48B	44mm x 18mm x 12mm	8 888313 165928

KCK Dust-Free Exam Grade Eraser - Black

KCK Dust-Free Exam Grade Eraser's residue and dust easily roll together for easier clean up after erasing. Exam Graded and suitable for daily school work as it effortlessly removes markings from mechanical led pencils. Great for home usage such as removing pencil markings from walls. The black colour makes the smears in the eraser unnoticeable. Only available in one size.

MESS FREE

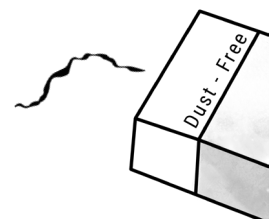

ER K60B KCK Premium Exam Grade Eraser
30mm x 15mm x 11mm

Order Code	Article Number	Dimensions	Barcode No.
	ERK60B	30mm x 15mm x 11mm	8 888313 169612

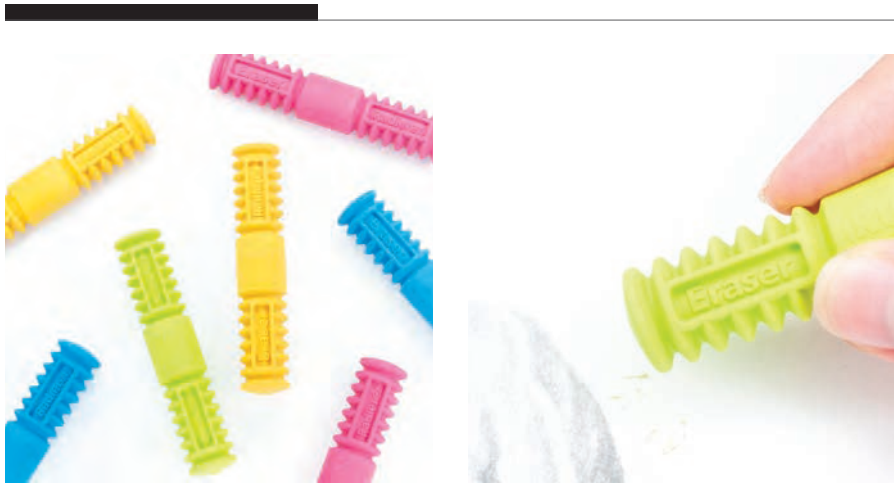

KUM® Softie Satellite D Eraser





Erase your paper and be amazed by its rubbing power as it erases any imperfections and mistakes so easily. Inspired by a satellite, this eraser does not leave any colour stain on the paper after erasing. Its soft, flexible nature makes the eraser comfortable to hold by hand. This elliptic shape ensures that large surfaces and accurate small surface erasing. his eraser is free of PVC, Phthalates and other harmful substances. Great to be used as a reduction method on mediums like charcoal, graphite, colour pencils and soft pastels.

Colour	Order Code	Barcode
	KU 4022324	
	KU 4022324	
	KU 4022324	
	KU 4022324	



KUM® Softie Tri Pop Eraser

Erase your paper and be amazed by its rubbing power as it erases any imperfections and mistakes so easily. This triangular shape design prevents the eraser from rolling away and eliminates unwanted smearing. This three-cornered shape design ensures the rubbing of small and large surface areas. This eraser is free of PVC, Phthalates and other harmful substances. Great to be used as a reduction method on mediums like charcoal, graphite, colour pencils and soft pastels.

Colour	Order Code	Barcode
	KU 4022424	
	KU 4022424	
	KU 4022424	
	KU 4022424	



KUM® Correc Stick Eraser

Erase your paper and be amazed by its rubbing power and its ergonomic grip. Inspired by ergonomics, this pen-shaped eraser has pointed and rounded ends that ensure comfortability and less straining on the hand after erasing for some time. Great for touch-ups or erasing large areas, this eraser also eliminates any unwanted smearing on paper. Made of durable rubber that's free of latex, PVC, phthalates smearing. Great to be used as a reduction method on mediums like charcoal, graphite, colour pencils and soft pastels.

Colour	Order Code	Barcode
	KU CSTICK	
	KU CSTICK	
	KU CSTICK	

KUM® SHARPENERS



KUM® 4 in 1 Pencil Sharpener - Pop Colours



2-hole on each side (KU 4INIPOP)

KUM® 4 in 1 Pencil Sharpener

You will hardly find a pencil that the KUM® 4 in 1 can't handle. KUM 4 in 1 Pencil Sharpener is one of the most versatile sharpeners as it features four sharpening holes from both sides. (Now you no longer need to find different sharpeners, its all in one!) Suitable for the pencils of triangular, hexagonal and round shapes, with the sizes 7mm to 11mm (slim, standard, jumbo). Designed with a click-clack option to keep the shavings from falling loose out of the container that can be easily emptied from both ends.

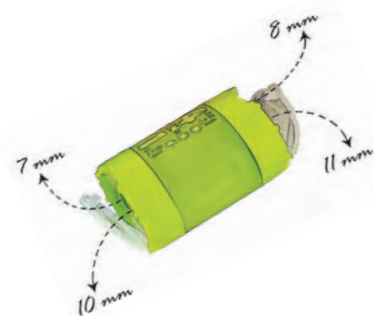

KUM® Superior quality blades



Colour	Order Code	Barcode
white	KU 4INIWT	
pastel	KU 4INIPAS	
pastel	KU 4INIPAS	
pastel	KU 4INIPAS	
pastel	KU 4INIPAS	
pop	KU 4INIPOP	
pop	KU 4INIPOP	
pop	KU 4INIPOP	
pop	KU 4INIPOP	
metallic	KU 4INIMET	
metallic	KU 4INIMET	
metallic	KU 4INIMET	



KUM Automatic Long Point Sharpener

Sharpen the wood and the lead of the pencil separately to achieve extra long pencil point! Insert the pencil into Blade 1 to sharpen the wood, leaving the lead exposed. Sharpen the lead to a very fine sharp point by using Blade 2. Suitable for graphite and colour pencils, lead holders and mechanical pencils, KUM Automatic Long Point Sharpener is very portable and great to use when you are on the go. Includes 2 replacement blades.

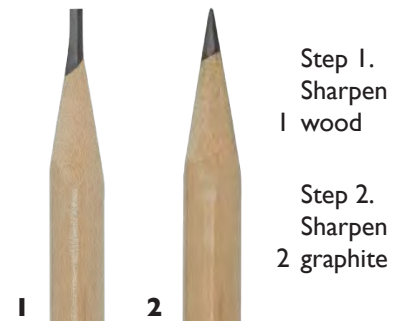

Automatic stop shapes only until the automatic stop

A set of spare replacement blades included

Colour	Order Code	Barcode
	KU AS2	



KUM Automatic Long Point Sharpener

Sharpen the wood and the lead of the pencil separately to achieve extra long pencil point! Insert the pencil into Blade 1 to sharpen the wood, leaving the lead exposed. Sharpen the lead to a very fine sharp point by using Blade 2. Suitable for graphite and colour pencils, lead holders and mechanical pencils, KUM Automatic Long Point Sharpener is very portable and great to use when you are on the go. Blades 3 and 4 allow you to sharpen mechanical pencils and lead holders of 2 mm and 3.15 mm to a fine point too! Includes 2 replacement blades.

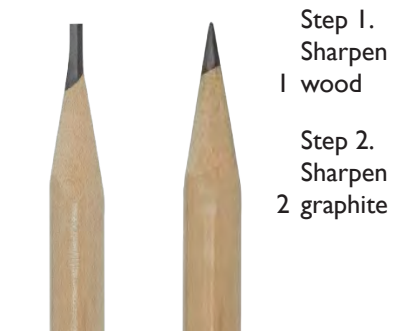

Lead point sharpeners to create a pointed tip (2mm)

Lead point sharpeners to create a pointed tip (3.15mm)

Colour	Order Code	Barcode
	KU AS2M	



KU CC

KUM® Click Clack Sharpener
2-Hole



○ - 8 mm
○ - 11 mm

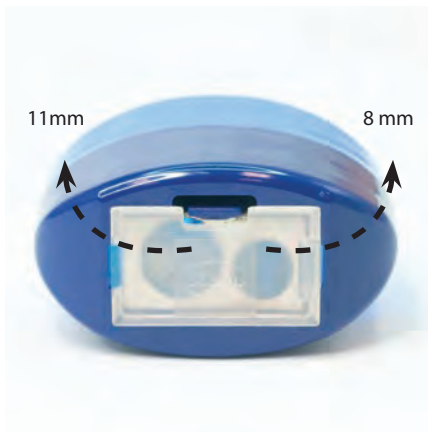

KU OVKM2

KUM® Oval Pencil Sharpener
2-Hole



○ - 8 mm
○ - 11 mm



KU 2IN1BOX

KUM® Box Container Sharpener
2-Hole



• 8 mm
• 11 mm



KU 228K2POP

KUM® Square Sharpener
2-Hole
POP



• 8 mm
• 11 mm





KU 208K2FT
KUM® Dome Sharpener
2-Hole



KU 100-20BRO
KUM® Standard Plastic Sharpener
2-Hole

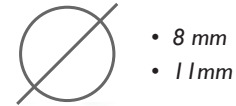

KU 218
KUM® Color - Combi Sharpener
2-Hole



Dull Pencils ideal
for less breakage &
smooth texture



Before Sharpening

After Sharpening



KU 206KICE

KUM® Flat Dome Container Sharpener
I-Hole
ICE

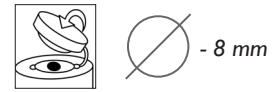

KU OVKKI

KUM® Oval Pencil Sharpener
I-Hole

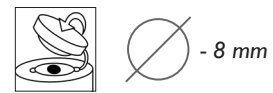

KU BUDDYKI

KUM® Buddy Sharpener
I-Hole

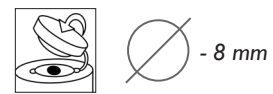

KU MINI1870

KUM® 1870 Mini Sharpener
I-Hole

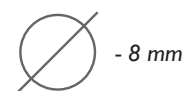



KU 100-1FT
KUM® Mini Sharpener
I-Hole
FT

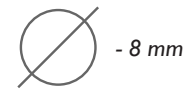

KU 100-15ICE
KUM® Mini Sharpener
I-Hole
ICE



KU 430
KUM® Plastic Container Sharpener
I-Hole

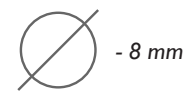

KU 450ICE
KUM® Plastic Container Sharpener
I-Hole
ICE

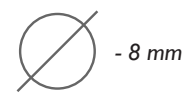



KU 222KIT
KUM® Square Sharpener
I-Hole

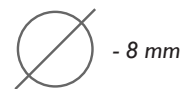

KU ROTARE-KI
KUM® Rotare Pencil Sharpener
I-Hole



Measurement: 42 X 25 X 42mm

KU 210-20POP
KUM® Dome Pencil Sharpener
I-Hole
POP

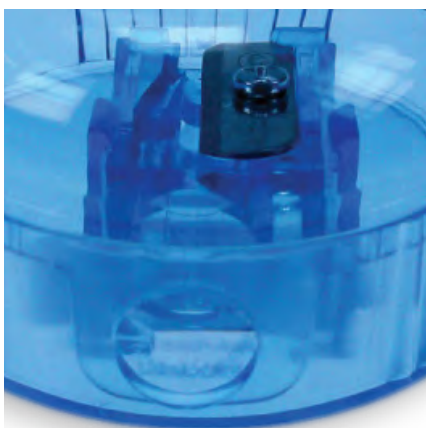

KU 210FT
KUM® Clear Dome Pencil Sharpener
I-Hole
FT





KU SQ
KUM® Squeaky Sharpener
I-Hole

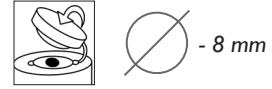

KU 226WAXT
KUM® Wax Crayon Sharpener
I-Hole

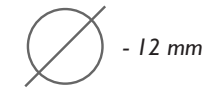

KU GLASSMI
KUM® 100 Years Glass Sharpener
I-Hole



Measurement: 75 x 40 x 40mm

Made up of glass, this sharpener promises longevity and durability with its additional timeless and elegant look. The large well contains a magnesium sharpener with a high carbon steel blade for maximum sharpness and durability. Suitable for pencils with diameters up to 8mm. A must-have desktop jar sharpener that looks polished and functional as well.



Canvas Bags

Travel anywhere with these lightweight, durable canvas bags.



STRONG
DURABLE



SUITABLE FOR PAINTING,
DRAWING & MIXED MEDIA



CBAGA6
Canvas Bag
A6 Size



CBAGA4
Canvas Bag
A4 Size

KCK Canvas Tote Bag

KCK Canvas Tote Bag is an excellent everyday bag to travel anywhere holding your favourite daily needs inside. Suitable for screen-printing/ printmaking and crafting projects, this bag is a perfect surface for wet mediums such as Fabric Markers, Acrylic Painting and dry mediums like oil pastels. Made up of cotton canvas, this bag ensures durability and is long-lasting. Available in A6 & A4 sizes, this bags stores all your favourite daily needs inside.



CBAGDRAWA6
Drawstring Canvas Bag
A6 Size



CBAGDRAWA4
Drawstring Canvas Bag
A4 Size

KCK Canvas Drawstring Bag

KCK Drawstring Bag is suitable as an everyday organizer in your travel bag. Perfect as a token of appreciation, gift this to your loved ones or hold a arts & craft project together. Suitable for screen-printing/ printmaking and crafting projects, this bag is a perfect surface for wet mediums such as Fabric Markers, Acrylic Painting and dry mediums like oil pastels. These canvas bags are made of durable material and secured with a drawstring that keeps everything intact.

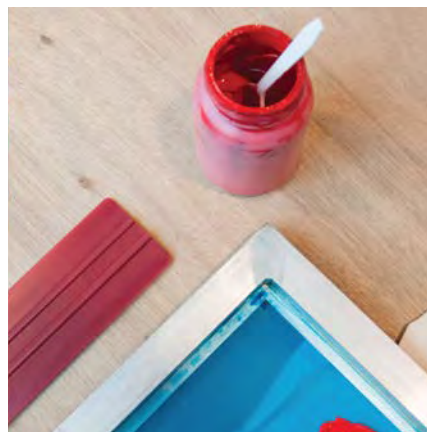

PVC Mesh Bag

Protect your items with our waterproof, tearproof PVC Mesh Bags.



**STRONG
DURABLE**



WATERPROOF



A4 Size (350x250mm)

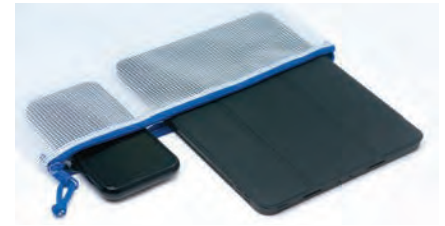

KCK PVC Mesh Bag

Use this PVC Mesh Bag and you will be surprised with its durable and tearproof quality. Made up of heavy-duty PVC Mesh, these bags can easily be folded and stowed neatly. Suitable to separate dry and wet mediums separately in your bag due to its waterproof characteristics. Store your wet mediums or dry mediums inside this bag and use this as a bag organiser to keep your whole bag from getting stained. This bag comes in 11 different sizes, so you can get the right size to fit your items.



Tag your name on the bag



Article No.	Size (H X W)	Size	Order Code	Barcode
	330X400mm	A3 Size	ZBI010A3	8 888313 161036
	250X353mm	B4 Size	ZBI010B4	8 888313 163818
	350x250mm	A4 Size	ZBI010A4	8 888313 161043
	300x220mm	B5 Size	ZBI010B5	8 888313 161050
	180x250mm	A5 Size	ZBI010A5	8 888313 161067
	200X150mm	B6 Size	ZBI010B6	8 888313 161685
	200x100mm	B6.5 Size	ZBI010B6.5	8 888313 161074
	130x170mm	A6 Size	ZBI010A6	8 888313 162170
	100x125mm	A7 Size	ZBI010A7	8 888313 164709
	140x280mm		ZBI0101428	8 888313 161692
	114x245mm	A5.5 Size	ZBI010A5.5	8 888313 168035

Foam Mounting Boards

5mm Thickness

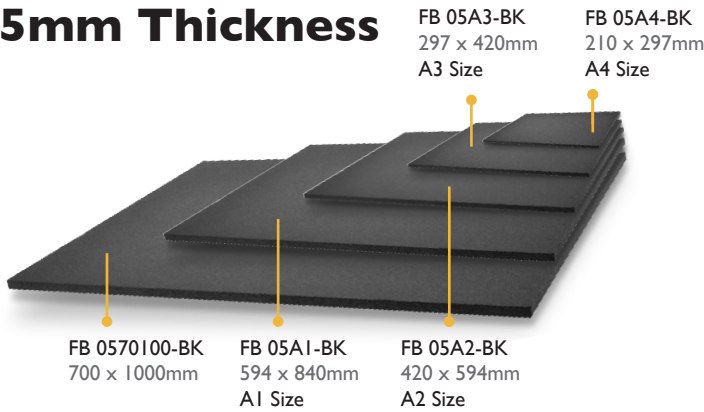

Foam Mounting Board (Black)
5mm Thickness

Size	Order Code	Barcode
A4 Size	FB 05A4-BK	
A3 Size	FB 05A3-BK	
A2 Size	FB 05A2-BK	
A1 Size	FB 05A1-BK	
70 X 100cm	FB 0570100-BK	

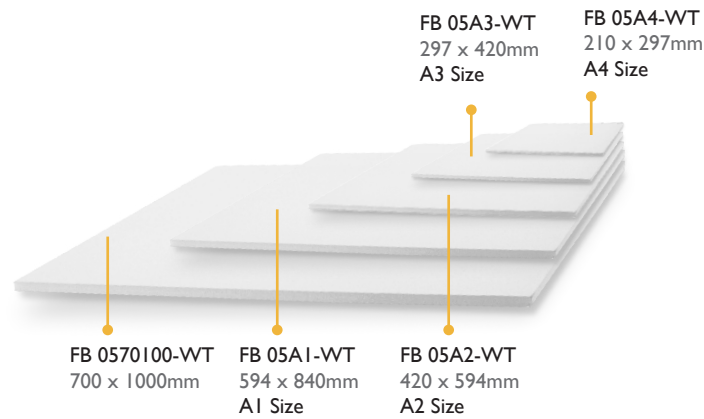

Foam Mounting Board (White)
5mm Thickness

Size	Order Code	Barcode
A4 Size	FB 05A4-WT	
A3 Size	FB 05A3-WT	
A2 Size	FB 05A2-WT	
A1 Size	FB 05A1-WT	
70 X 100cm	FB 0570100-WT	

10mm Thickness

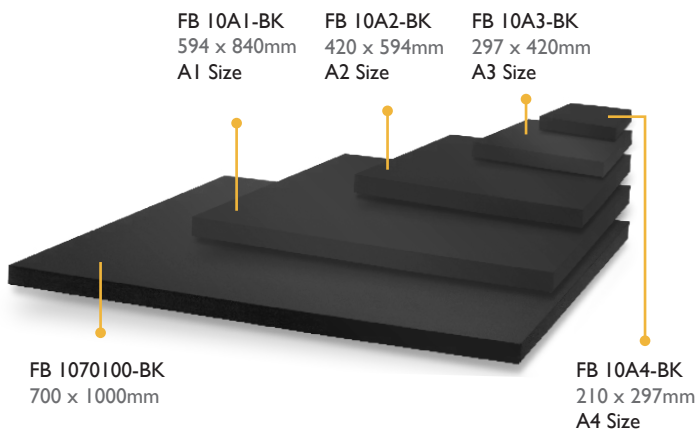

Foam Mounting Board (Black)
10mm Thickness

Size	Order Code	Barcode
A4 Size	FB 10A4-BK	
A3 Size	FB 10A3-BK	
A2 Size	FB 10A2-BK	
A1 Size	FB 10A1-BK	
70 X 100cm	FB 1070100-BK	

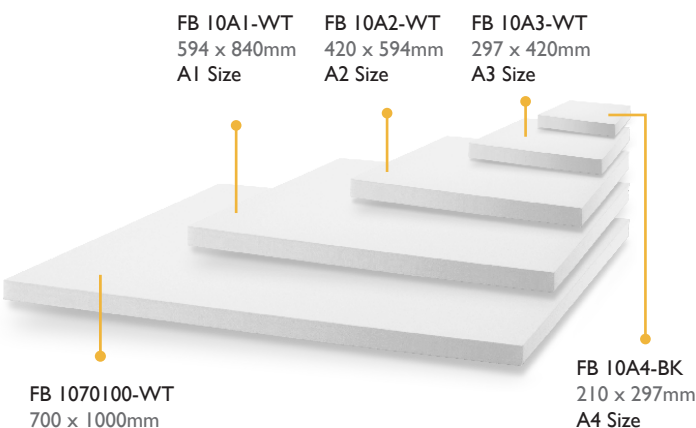

Foam Mounting Board (White)
10mm Thickness

Size	Order Code	Barcode
A4 Size	FB 10A4-WT	
A3 Size	FB 10A3-WT	
A2 Size	FB 10A2-WT	
A1 Size	FB 10A1-WT	
70 X 100cm	FB 1070100-WT	

Styrofoam Shapes



SR CONE
Styrofoam Cone

Size (H X D)	Qty	Order Code	Barcode
11cm x 5cm	3 Pieces	SR CONE1105-03	
3cm x 2cm	20 Pieces	SR CONE0203-20	



SR STAR
Styrofoam Star

Size	Qty	Order Code	Barcode
15cm	1 Piece	SR STAR15-01	
12cm	2 Pieces	SR STAR12-02	
7cm	6 Pieces	SR STAR07-06	



SR ROD
Styrofoam Rod

Size (H X D)	Qty	Order Code	Barcode
10cm x 4cm	3 Pieces	SR ROD1004-03	
5cm x 3cm	8 Pieces	SR ROD0503-08	



SR BALL
Styrofoam Ball



SR RING
Styrofoam Ring



SR EGG
Styrofoam Egg

Size	Qty	Order Code	Barcode
20cm	1 Piece	SR BALL20-01	
15cm	1 Piece	SR BALL15-01	
10cm	1 Piece	SR BALL10-01	
8cm	2 Pieces	SR BALL08-02	
5cm	6 Pieces	SR BALL05-06	

Size	Qty	Order Code	Barcode
14cm	2 Pieces	SR RING14-02	
12cm	2 Pieces	SR RING12-02	
10cm	3 Pieces	SR RING10-03	

Size	Qty	Order Code	Barcode
7cm	4 Pieces	SR EGG007-04	
3cm	20 Pieces	SR EGG03-20	



SR HR06-08
Styrofoam Heart Ring
6cm
8 pieces



SR HF06-06
Styrofoam Heart Full
6cm
6 pieces



SR HF06-06
Styrofoam Heart Flat
5cm
12 pieces





Book 5 - Craft & Stationaries



PLEASE RECYCLE

www.kck.sg

MODELLING & CLAY



Introduction

Choong Marketing was established in 1998 by Mr K C Kang. We are an importer/exporter and distributor of stationery and art-based materials in Singapore. Since then, it is our company mission to supply our customers with quality products. Over the years we have grown at a steady pace; increasing product range, brand representation and channels to customers. As we continue to grow, we will continue to strengthen our position by working with partners with shared values and not forgetting our mission of providing ordinary products with extraordinary quality.

Manufacturing

We manufacture the DREAM brand in our own facilities and other than the regular selections, we can work with different customers on their own brand and specifications.

The Brands

If people are the company's right hand, the brands and partners would surely be its left hand. We value every brand we represent and it's our preference to work with brands that complement each other so that we would be able to grow in strength together. The following are brands that we represent exclusively:

•AMOS •CARIOCA •DREAM
•KANGARO •KCK QUALITY •KCK CRAFT
•KEBA KUM •MARVY UCHIDA •MONTANA CANS
•PLAY •SADIPAL •SIO-2 •KUSAKABE •SENNELIER
•PAPA CLAY •ALPHA COLOURS •YOUNG ARTIST

Contents

Pg 4	SIO-2 Self Hardening Clay
Pg 5	SIO-2 Pottery & Stoneware Clay
Pg 6	SIO-2 Porcelain Clay & Tools
Pg 7	KCK Air-Dry & Modelling Clay
Pg 8	Clay World Polymer Clay
Pg 9	Clay World Modelling Clay & KCK Acrylic Board
Pg 10	KCK Art Knife Set with Blade & Tools
Pg 11	Embossing Tool Set & Ceramic Tool Set

SIO-2 PLUS® Self-Hardening Clay

SIO-2 PLUS® is natural self-hardening clay, no firing is necessary. After drying, it achieves high hardness, strength and solidity. It is a suitable material for the development of creative skills and plastic expression. Recommended in handicrafts and professional creative arts, and also suitable for children (from 3 years old). Its natural clay components give excellent plasticity to the modelled item and the presence of natural fibres of cellulose allows a secure drying, free of cracks and fissures, even for the large pieces.



Order Code	Article Number	Colour	Weight	Barcode
	S2 2022001000	White	500g	
	S2 2026000400	White	5kg	
	S2 2032001000	Terracotta	500g	
	S2 2036000400	Terracotta	5kg	
	S2 2132001000	Black	500g	

SIO-2® COLORPLUS Coloured Self-Hardening Clay

SIO-2® COLORPLUS is coloured natural self-hardening clay, no firing is necessary. After drying, it achieves a high hardness and solidity. It is a suitable material for the development of creative skills and plastic expression. Recommended in handicrafts and professional creative arts, and also suitable for children (from 3 years old). Its natural clay components give excellent plasticity to the modelled item and the presence of natural fibres of cellulose allows a secure drying, free of cracks and fissures, even for the large pieces.







Order Code	Article Number	Colour	Weight	Barcode
	S2 2452000218	White	500g	
	S2 2162000218	Yellow	500g	
	S2 2182000218	Red	500g	
	S2 2152000218	Green	500g	
	S2 2142000218	Blue		



SIO-2 ® ARGILA Natural Pottery Clay

SIO-2 ® ARGILA is 100% natural pottery clay. Easy and pleasant to work with. Ideal for modelling, sculpturing and the potter's wheel. It is an educational material adequate for the development of creativity. Suitable for children (from 3 years old) and is also recommended for use in creative and decorative arts, and in many other cases, when natural clay is required. Its plasticity is well balanced in order to achieve best results during the modelling, drying and firing. Firing: 1000°C (Cone 06) for the red colour, and 1050°C (Cone 04) for the white.



 natural clay
  odorless
  excellent plasticity
  requires firing



Order Code	Article Number	Colour	Weight	Barcode
	S2 2044000110	White	1.5kg	
	S2 2046000100	White	5kg	
	S2 2094000110	Red	1.5kg	
	S2 2016000100	Red	5kg	



SIO-2 Stoneware Clay

Stoneware clay is made for sculpting and modelling due to its excellent plasticity. This stoneware clay comprise of 40% grog 0-0.5 mm (fine). The high content of the grog gives a beautiful, gritty and textured surface called "tooth" and an excellent behaviour during drying and firing. The grog containing clay reduces shrinkage during drying and firing aiding the drying process as it prevents cracking, crows feet patterning in your clay projects. After firing at (1240-1300°C) in an oxidising atmosphere, the colour of the clay will turn intense than when it's dried.



 stoneware clay
  intense colours
  excellent plasticity
  requires firing



Order Code	Article Number	Colour	Weight	Barcode
	S2 1122010000	Teide (Dark Toasted Brown)	5kg	
	S2 1362010000	Lanzarote (Intense Black)	5kg	

SIO-2® Porcelain Clay

SIO-2® Porcelain is made out of raw materials that provide it with high resistance, high durability and unique translucency. Because it is a non-porous material, it becomes extremely hygienic and ideal for tableware (food-safe), according to ISO 6486. Its delicateness and beauty make porcelain elegant, timeless and suitable for any event. Presented in a practical 5 kg cylindrical format with double packaging. The result is an extremely hard, shiny material often translucent in appearance. Also ideal for decorative objects and porcelain tiles.

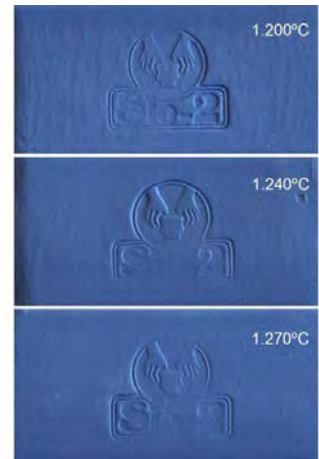

porcelain
clay



intense
colours



excellent
plasticity



requires
firing

Order Code	Article Number	Colour	Weight	Barcode
		Aneto	5kg	
		Upsala	5kg	
		Black Ice	5kg	



Black Ice Porcelain Bowl by Olivia Walker

SIO-2 Pottery Wheel



Order Code	Article Number	Size	Barcode
	S2 3700001100	18cm	

Wooden Clay Tools - 15

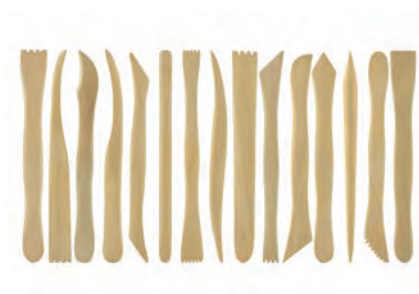

Order Code	Article Number	Barcode
	S2 2022001000	

SIO-2 Pottery Tool Kit



Order Code	Article Number	Barcode
	S2 3700000900	

SIO-2 Roller - Wood



Order Code	Article Number	Barcode
	S2 3700003000	

SIO-2 Embossing Tools - Set of 2



Order Code	Article Number	Barcode
	S2 3700001900	

SIO-2 Ribbon Tools - Set of 2



Order Code	Article Number	Barcode
	S2 3700002900	

KCK Air Dry Clay 500G - White

KCK Air Dry Clay is a premium quality modelling clay that requires no firing. The clay hardens naturally within 24 hours of exposure to air, drying time may differ depending on the environmental conditions and the size of the artwork. KCK Air Dry Clay leaves no powdery traces making it suitable for treatment with watercolour, tempera or acrylic paint once dry. It is a suitable material for the development of creative skills for children (from 3 years old). Suitable for necklace, bowl making, handicrafts projects. Made in Italy.



Medium | 24 hours | Excellent Plasticity
Drying Time

Order Code	Article Number	Barcode
	HC CY500W	

Figurines made from Sculpture Pro @mihart_

KCK Modelling Clay (Plasticine) - 500g

Clay World's Sculpture Pro Oil-Based Modelling Clay is a non-drying clay suitable for industrial use such as vehicle modelling, sculptural art, clay figurines and mini statues. Perfect for mould-making and rapid prototyping by pouring the mould mixture onto your sculpture pro. Available in two hardness; Soft & Medium, these clays do not need to be heated up to use. The smooth consistency of these clay allows the artist to achieve fine details and it is safe for children above the age of 8.



Order Code	Colour	Barcode
HC MCP500	White	
HC MCP500	Flesh	
HC MCP500	Yellow	
HC MCP500	Orange	
HC MCP500	Red	
HC MCP500	Purple	
HC MCP500	Green	
HC MCP500	Blue	
HC MCP500	Brown	
HC MCP500	Black	

Soft | Non-Drying | Excellent Plasticity

KCK™
C·R·A·F·T
MESS FREE

Clay World PAPA'S Polymer Clay

PAPA'S Polymer Clay is a man-made clay consisting of a polyvinyl (PVC) base. Unlike air-dry clay, polymer clay will not harden when you leave it out at room temperature so that you can easily set your project aside and return to them later. (As long as you keep it away from heat and direct sunlight) Using a home oven or toaster oven to cure and preheat your oven at 130°C/ 265F and bake your polymer clay. Ideal for sculpting, jewelry making, crafting, stop motion animation. The smooth consistency of these clay allows the artist to achieve fine details and suitable for children above the age of 3 as it is certified non-toxic.



Measurement: 6x1.7x5.5cm (LxWxH)



NEW: Clay has to be conditioned before using





Clay soften quickly
easily in your hands



Preheat the oven
at 130°C / 265F



Store leftover clay
in a ziplock bag

Article No.	Order Code	Colour Name	Barcode
	PPC75-19BB	Baby Blue	8 600102 229594
	PPC75-20SB	Sky Blue	8 600102 229600
	PPC75-23OB	Ocean Blue	8 600102 229631
	PPC75-24NB	Navy Blue	8 600102 229648
	PPC75-21TQ	Turquoise	8 600102 229617
	PPC75-22TB	Turquoise Blue	8 600102 229624
	PPC75-30PG	Pine Green	8 600102 229709
	PPC75-25MG	Mint Green	8 600102 229655
	PPC75-28OG	Olive Green	8 600102 229686
	PPC75-29GN	Green	8 600102 229693
	PPC75-27LG	Leaf Green	8 600102 229679
	PPC75-36KG	Kiwi Geen	8 600102 229761
	PPC75-26NG	Neon Green	8 600102 229662
	PPC75-04NY	Neon Yellow	8 600102 229440
	PPC75-02YL	Yellow	8 600102 229426
	PPC75-03WY	Warm Yellow	8 600102 229426
	PPC75-05MY	Mustard Yellow	8 600102 229617
	PPC75-31LA	Latte	8 600102 229716

Article No.	Order Code	Colour	Barcode
	PPC75-33CB	Chocolate Brown	8 600102 229730
	PPC75-32BR	Brown	8 600102 229723
	PPC75-06OC	Ochre	8 600102 229464
	PPC75-07LF	Light Flesh	8 600102 229471
	PPC75-09NP	Neon Peach	8 600102 229495
	PPC75-10OR	Orange	8 600102 229501
	PPC75-12RD	Red	8 600102 229525
	PPC75-11KR	Coral Red	8 600102 229518
	PPC75-15PK	Pink	8 600102 229556
	PPC75-13BR	Baby Rose	8 600102 229532
	PPC75-16FU	Fuchsia	8 600102 229563
	PPC75-18PU	Purple	8 600102 229587
	PPC75-17LP	Light Purple	8 600102 229570
	PPC75-14LL	Lilac	8 600102 229549
	PPC75-01WT	White	8 600102 229419
	PPC75-34GY	Grey	8 600102 229747
	PPC75-35BK	Black	8 600102 229754



Clay World Sculpture Pro Modelling Clay

Clay World's Sculpture Pro Oil-Based Modelling Clay is a non-drying clay suitable for industrial use such as vehicle modelling, sculptural art, clay figurines and mini statues. Perfect for mould-making and rapid prototyping by pouring the mould mixture onto your sculpture pro. Available in two hardness; Soft & Medium, these clays do not need to be heated up to use. The smooth consistency of these clay allows the artist to achieve fine details and it is safe for children above the age of 8.



NEW: Figurines made from Sculpture Pro @mihart_



Medium & Soft



Non-Drying



Excellent Plasticity



SCULPTUREPRO

Article Number	Order Code	Hardness	Colour	Barcode
	SPRO250-GYM	Medium	Grey	8 600102 229792
	SPRO250-GYS	Soft	Grey	8 600102 229778
	SPRO250-TCM	Medium	Terracotta	8 600102 229808
	SPRO250-TCS	Soft	Terracotta	8 600102 229785



NEW: Measurement: 15x1x10cm

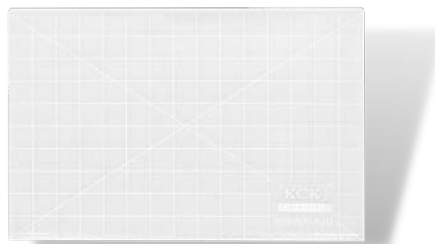

KCK Clear Stamp Acrylic Board

KCK Clear Cutting Acrylic Board is made from premium quality acrylic that is strong and durable. Suitable to be used with polymer, modelling, air-dry clay & natural clay, this board protects your work surfaces from getting stained with clay. Condition polymer clay by warming clay with hands and flattening it with this acrylic board. With a smooth surface, any leftover clay can be removed easily. Measuring 15x1x10cm, this acrylic board is ideal for stamping, shape-making and conditioning clay.

Order Code	Article Number	Barcode
	HCABI015	8 888313 089743

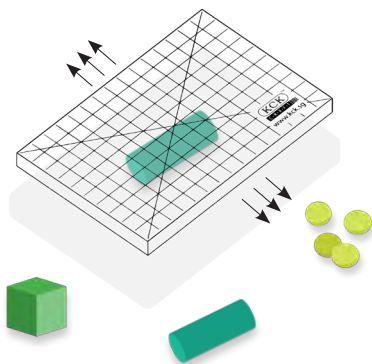

Use this acrylic board like a rolling pin

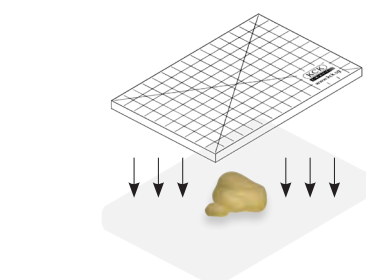
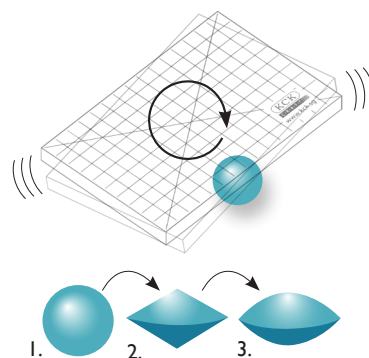

Condition polymer clay by continuously flattening it

New

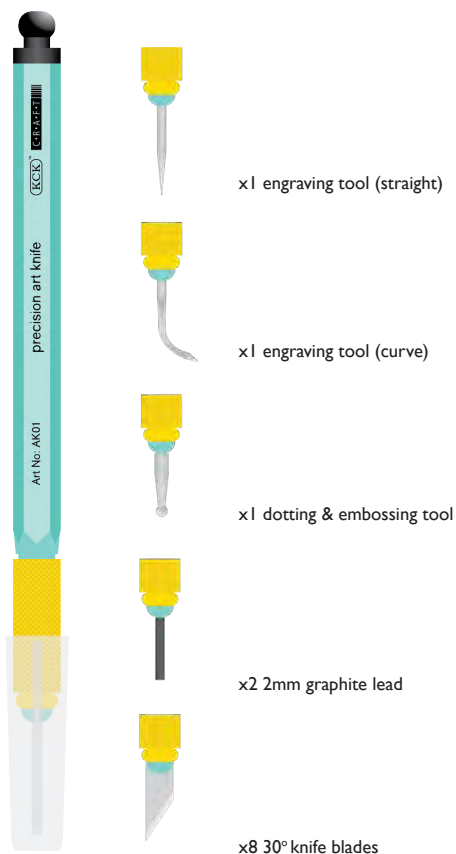

NEW: Interchangeable blades, tools and leads



KCK Art Knife Set With Blades + Tools

KCK Art Knife with Blades & Tools has a lightweight high-quality plastic body fitted with a comfortable stainless steel grip barrel that is able to be twisted and removed to change the blades. Perfect for Clay Art, Jewellery Making, Stone Carving, Metal Embossing, Paper Cutting, Drawing etc. This art knife is designed to accommodate multiple uses such as intricate cutting, carving, sketching jobs etc. This art knife comes with an embossing tool, 2 engraving tools, 2 graphite leads and 8 knife blades.



Measurement (cm)	30° knife blade	graphite lead	embossing tool	engraving tool(straight)	engraving tool(curve)
Nib Length	3.9	2.4	3	3.5	3.5
Tip Diameter	0.6	0.2	0.3	0.2	0.3
Total Length	15.5	15.5	15	16	16.5
Order Code		Article No.	CUAK01	Barcode	



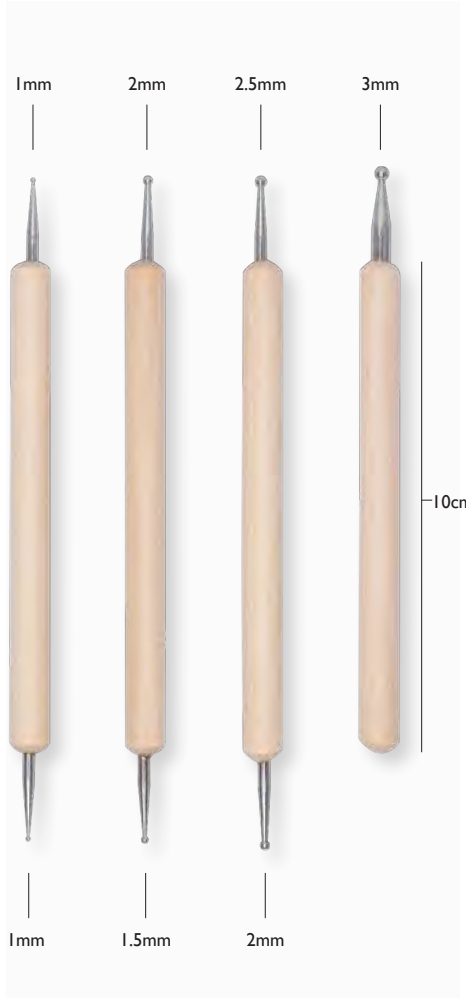

Embossing Tool Set

KCK Embossing toolset is made with wooden handles and stainless steel tips. This tool set is perfect for carving raised patterns, textures and design. They are also ideal for painting on rocks, Mandela art, embossing on metal, forming deeper marks for embellishment. This set includes 3 double-ended and 1 wooden handle stylus tools for all your tracing, embossing and etching needs. The ball tips are polished and do not damage the surface of your project. Ideal for clay works, nail arts and metal embossing, this embossing tool set has 5 sizes of tips, 1mm, 1.5mm, 2mm, 2.5mm, and 3mm.



Strong



Wood Barrel



Steel Tips

Order Code	Article Number	Barcode
	HCTLEB-03	

Ceramic Tool Set

Comes in 5 different shapes of silicon tips, this brush set does not absorb any material and is easy to clean. Great for carving, shaping clay and spreading PVA glue. This Silicone Brush Set is made up of high-quality wood and metal ferrule which is lightweight and easy to carry. This toolset is perfect for removing unwanted fingerprints on the surface of your clay project and create effects such as colour shaping, fine detailing, retouching harsh lines. The silicone tip of the brush is very flexible, but also has good abrasion resistance that can easily be used for clay carving, shaping, nail and art projects.



Strong



Wood Barrel



Silicone Tip

Measurement (cm)	Cup Round	Taper Point	Flat Chisel	Cup Chisel	Angle Chisel
Nib Length	2.3	2	2.2	2.3	2.5
Ferrule Diameter	1.3	1.3	1.3	1.3	1.3
Total Length	18.4	18.4	17.8	18.1	18
Order Code		Article No.	HCTL25-6	Barcode	



Resin Silicone Mold

Resin silicone molds are made of strong silicone resin using advanced technology. Excellent high tear strength and smooth inner surface, and reusable epoxy mold. You can easily use and demold.

- Perfect for making decorative resin crafts such as pen holder, soap holder, wax candle holder, flower plants port, compatible with most resins or other casting materials.

- Easy to De-mold: Smooth interior makes it easy to de-mold after it's fully cured and reduces the need to cut back and polish. Or you can use release spray or soap water which may help extend silicone mold's life.

- Durable and Not Easily Deformed: Our molds are made up of pure silicone with excellent elasticity, superior high tear strength, etc. After squeezing and deforming, just rest for a while and then will return to the original state.

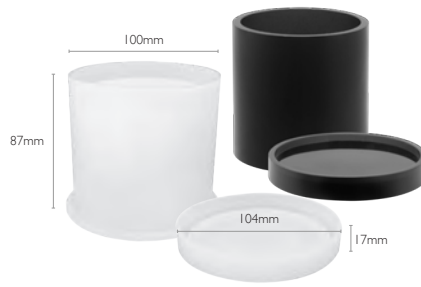

Cylinder + Base

Article Number	Barcode
HC SM1651	

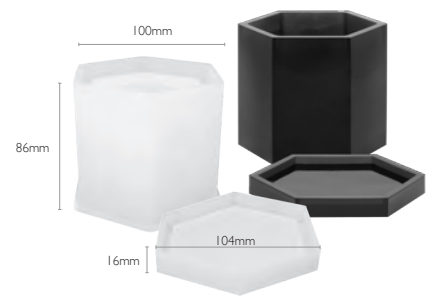

Hexagon + Base

Article Number	Barcode
HC SM1652	

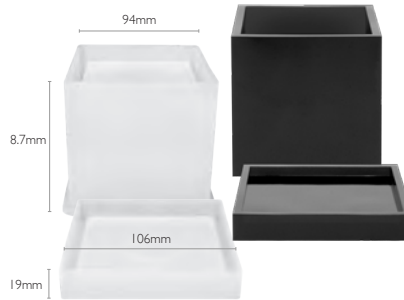

Square + Base

Article Number	Barcode
HC SM1653	



Fish Bowl

Article Number	Barcode
HC SM1654	

How to clean:

Please clean the resin casting molds with rubbing alcohol or soapy water, and use a soft cloth to wipe clean.

How to store:

Please store the silicone art resin molds away from direct sunlight and dust.

How to demold:

It can be taken out just by pulling the resin mold. You can also use a mold release spray. If you don't have, you may use a baby wipe or a drop of soap mix with a bit of water as a release agent.

Note: Please make sure your resin piece is fully cured. The time to complete solidification depends on the type of resin liquid you used.

Warning! For the small pieces, please keep away from babies, kids, children.



Round Rectangle

Article Number	Barcode
HC SM1655	



Round Corner Square

Article Number	Barcode
HC SM1656	



Hexagon

Article Number	Barcode
HC SM1657	

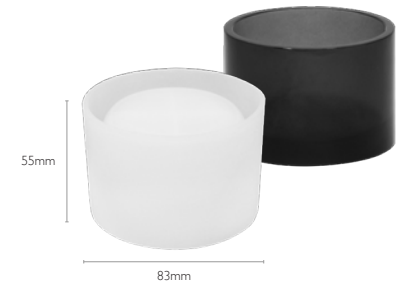

Cylinder

Article Number	Barcode
HC SM1658	

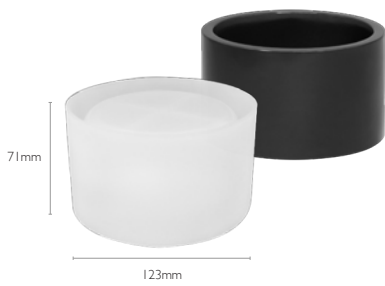

Cylinder

Article Number	Barcode
HC SM1659	



Textured Cylinder + Base

Article Number	Barcode
HC SM1660	

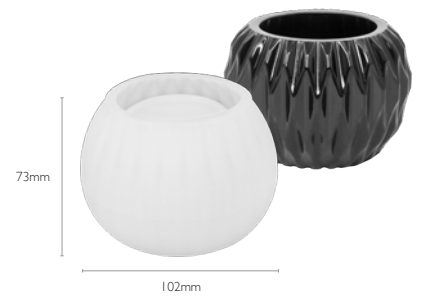

Fish Bowl

Article Number	Barcode
HC SM1661	



Textured

Article Number	Barcode
HC SM1662	



Bowl

Article Number	Barcode
HC SM1663	

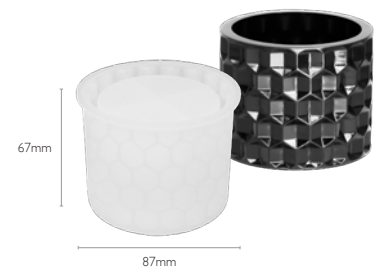

Honeycomb Pot

Article Number	Barcode
HC SM1664	

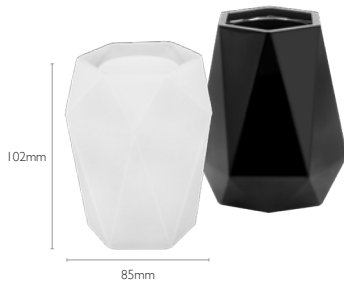

Flower Vase

Article Number	Barcode
HC SM1665	



Flower Vase Strips

Article Number	Barcode
HC SM1666	

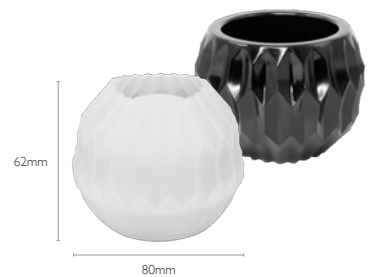

Bowl

Article Number	Barcode
HC SM1667	



Cup

Article Number	Barcode
HC SM1668	



Bowl

Article Number	Barcode
HC SM1669	

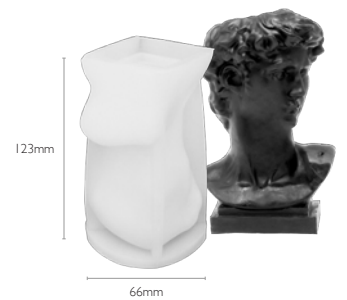

David Pot

Article Number	Barcode
HC SM1670	



Measuring Cup 250ml

Article Number	Barcode
HC MC10250	



Measuring Cup 500ml

Article Number	Barcode
HC MC10500	



Measuring Cup 1000ml

Article Number	Barcode
HC MC11000	



Measuring Cup 250ml

Article Number	Barcode
HC MC20250	



Measuring Cup 500ml

Article Number	Barcode
HC MC20500	



Measuring Cup 1000ml

Article Number	Barcode
HC MC21000	

Crystal Clear Epoxy Resin

Crystal clear finish no experience needed, good for all kinds of DIY projects, big or small, from paint pouring art to creating crafts like jewelry, resin coasters, table top.

- Crystal Clear Epoxy Resin: Crystal clear finish no experience needed, good for all kinds of DIY projects, big or small, from paint pouring art to creating crafts like jewelry, resin coasters, table top.

- Bubble Free Clear Resin: This clear casting resin is as transparent and clean as glass, bubble-free, great for making layered, deep pieces like jewelry or molds. Moreover, compared with the traditional epoxy resin, this epoxy resin for the craft is featured by its non-toxic, low odor, and yellowing resistance. Make you complete your perfect artwork without other worries.



HC EPI10-200

KCK Epoxy Resin "Coat & Cast"
200ml Pack



HC EPI10-480

KCK Epoxy Resin "Coat & Cast"
480ml Pack



HC EP310-960

KCK Epoxy Resin
"3D Deep Cast"
960ml Pack





Book 6 - Modelling & Clay



PLEASE RECYCLE

www.kck.sg